



U.S. Department  
of Transportation  
**Federal Highway  
Administration**

1200 New Jersey Ave., SE  
Washington, D.C. 20590

July 3, 2013

In Reply Refer To:  
HSST/SS-179

Mr. Gregory R. Brinkmeyer, P.E.  
Hori-Zone Concepts LLC  
14417 Chandler Road  
Taylor, Texas 76574

Dear Mr. Brinkmeyer,

This letter is in response to your request for the Federal Highway Administration (FHWA) to review a roadside safety system for eligibility for reimbursement under the Federal-aid highway program.

Name of system:	Centerline Supply Triangular Slipbase Locking Sign Collar Assembly
Type of system:	Breakaway sign support
Test Level:	NCHRP Report 350 Test Level 3
Testing conducted by:	N/A
Date of request:	May 15, 2013
Date initially acknowledged:	June 12, 2013
Date of completed package:	May 15, 2013

### **Decision**

The following device is eligible, with details provided in the form which is attached as an integral part of this letter:

- Centerline Supply Triangular Slipbase Breakaway Sign Support with Locking Sign Collar Assembly

Based on a review of crash test results referenced by the manufacturer certifying the device described herein conforms to the Texas Department of Transportation standard triangular slip base for small sign supports, and meets the crash test and evaluation criteria of the National Cooperative Highway Research Program (NCHRP) Report 350, the device is eligible for reimbursement under the Federal-aid highway program. Eligibility for reimbursement under the Federal-aid highway program does not establish approval or endorsement by the FHWA for any particular purpose or use.

The FHWA, the Department of Transportation, and the United States Government do not endorse products or services and the issuance of a reimbursement eligibility letter is not an endorsement of any product or service.

### **Requirements**

To be found eligible for Federal-aid funding, roadside safety devices should meet the crash test and evaluation criteria contained in the NCHRP Report 350 or the American Association of State Highway and Transportation Officials' Manual for Assessing Safety Hardware (MASH).

### **Description**

The device and supporting documentation are described in the attached form and drawing. It augments the standard generic three-bolt slip base breakaway sign support by adding a collar and locking mechanism to prevent the sign from rotating due to vibrations.

### **Summary and Standard Provisions**

Therefore, the system described and detailed in the attached form and drawings is eligible for reimbursement and may be installed under the range of conditions tested.

Please note the following standard provisions that apply to FHWA eligibility letters:

- This finding of eligibility does not cover other structural features of the systems, nor conformity with the Manual on Uniform Traffic Control Devices.
- Any changes that may influence system conformance with NCHRP Report 350 criteria will require a new reimbursement eligibility letter.
- Should the FHWA discover that the qualification testing was flawed, that in-service performance reveals safety problems, or that the system is significantly different from the version that was crash tested, we reserve the right to modify or revoke this letter.
- You are expected to supply potential users with sufficient information on design and installation requirements to ensure proper performance.
- You are expected to certify to potential users that the hardware furnished has the same chemistry, mechanical properties, and geometry as that submitted for review, and that it will meet the crash test and evaluation criteria of the NCHRP Report 350.
- To prevent misunderstanding by others, this letter of eligibility is designated as number SS-179 and shall not be reproduced except in full. This letter and the test documentation upon which it is based are public information. All such letters and documentation may be reviewed at our office upon request.
- This letter shall not be construed as authorization or consent by the FHWA to use, manufacture, or sell any patented system for which the applicant is not the patent holder. The FHWA does not become involved in issues concerning patent law. Patent issues, if any, are to be resolved by the applicant.
- The Centerline Supply Triangular Slipbase Locking Sign Collar Assembly is a patented product and considered proprietary. If proprietary systems are specified by a highway agency for use on Federal-aid projects: (a) they must be supplied through competitive bidding with equally suitable unpatented items; (b) the highway agency must certify that they are essential for synchronization with the existing highway facilities or that no equally suitable alternative exists; or (c) they must be used for research or for a

distinctive type of construction on relatively short sections of road for experimental purposes. Our regulations concerning proprietary products are contained in Title 23, Code of Federal Regulations, Section 635.411.

Sincerely yours,

Michael S. Griffith  
Director, Office of Safety Technologies  
Office of Safety

Enclosures



U.S. Department  
of Transportation  
**Federal Highway  
Administration**

1200 New Jersey Ave., SE  
Washington, D.C. 20590

July 3, 2013

In Reply Refer To:  
HSST/SS-179

Mr. Gregory R. Brinkmeyer, P.E.  
Hori-Zone Concepts LLC  
14417 Chandler Road  
Taylor, Texas 76574

Dear Mr. Brinkmeyer,

This letter is in response to your request for the Federal Highway Administration (FHWA) to review a roadside safety system for eligibility for reimbursement under the Federal-aid highway program.

Name of system:	Centerline Supply Triangular Slipbase Locking Sign Collar Assembly
Type of system:	Breakaway sign support
Test Level:	NCHRP Report 350 Test Level 3
Testing conducted by:	N/A
Date of request:	May 15, 2013
Date initially acknowledged:	June 12, 2013
Date of completed package:	May 15, 2013

#### **Decision**

The following device is eligible, with details provided in the form which is attached as an integral part of this letter:

- Centerline Supply Triangular Slipbase Breakaway Sign Support with Locking Sign Collar Assembly

Based on a review of crash test results referenced by the manufacturer certifying the device described herein conforms to the Texas Department of Transportation standard triangular slip base for small sign supports, and meets the crash test and evaluation criteria of the National Cooperative Highway Research Program (NCHRP) Report 350, the device is eligible for reimbursement under the Federal-aid highway program. Eligibility for reimbursement under the Federal-aid highway program does not establish approval or endorsement by the FHWA for any particular purpose or use.

The FHWA, the Department of Transportation, and the United States Government do not endorse products or services and the issuance of a reimbursement eligibility letter is not an endorsement of any product or service.

### **Requirements**

To be found eligible for Federal-aid funding, roadside safety devices should meet the crash test and evaluation criteria contained in the NCHRP Report 350 or the American Association of State Highway and Transportation Officials' Manual for Assessing Safety Hardware (MASH).

### **Description**

The device and supporting documentation are described in the attached form and drawing. It augments the standard generic three-bolt slip base breakaway sign support by adding a collar and locking mechanism to prevent the sign from rotating due to vibrations.

### **Summary and Standard Provisions**

Therefore, the system described and detailed in the attached form and drawings is eligible for reimbursement and may be installed under the range of conditions tested.

Please note the following standard provisions that apply to FHWA eligibility letters:

- This finding of eligibility does not cover other structural features of the systems, nor conformity with the Manual on Uniform Traffic Control Devices.
- Any changes that may influence system conformance with NCHRP Report 350 criteria will require a new reimbursement eligibility letter.
- Should the FHWA discover that the qualification testing was flawed, that in-service performance reveals safety problems, or that the system is significantly different from the version that was crash tested, we reserve the right to modify or revoke this letter.
- You are expected to supply potential users with sufficient information on design and installation requirements to ensure proper performance.
- You are expected to certify to potential users that the hardware furnished has the same chemistry, mechanical properties, and geometry as that submitted for review, and that it will meet the crash test and evaluation criteria of the NCHRP Report 350.
- To prevent misunderstanding by others, this letter of eligibility is designated as number SS-179 and shall not be reproduced except in full. This letter and the test documentation upon which it is based are public information. All such letters and documentation may be reviewed at our office upon request.
- This letter shall not be construed as authorization or consent by the FHWA to use, manufacture, or sell any patented system for which the applicant is not the patent holder. The FHWA does not become involved in issues concerning patent law. Patent issues, if any, are to be resolved by the applicant.
- The Centerline Supply Triangular Slipbase Locking Sign Collar Assembly is a patented product and considered proprietary. If proprietary systems are specified by a highway agency for use on Federal-aid projects: (a) they must be supplied through competitive bidding with equally suitable unpatented items; (b) the highway agency must certify that they are essential for synchronization with the existing highway facilities or that no equally suitable alternative exists; or (c) they must be used for research or for a

distinctive type of construction on relatively short sections of road for experimental purposes. Our regulations concerning proprietary products are contained in Title 23, Code of Federal Regulations, Section 635.411.

Sincerely yours,

A handwritten signature in blue ink that reads "Michael S. Griffith". The signature is written in a cursive style with a large initial "M" and a stylized "S".

Michael S. Griffith  
Director, Office of Safety Technologies  
Office of Safety

Enclosures

## Request for Federal Aid Reimbursement Eligibility Of Highway Safety Hardware

<b>Submitter</b>	Date of Request:	May 15, 2013	<input checked="" type="radio"/> New <input type="radio"/> Resubmission
	Name:	Gregory R. Brinkmeyer, P.E.	Signature: <i>Gregory R. Brinkmeyer, P.E.</i>
	Company:	Hori-Zone Concepts LLC	
	Address:	14417 Chandler Road; Taylor, TX 76574	
	Country:	USA	
	To:	Michael S. Griffith, Director FHWA, Office of Safety Technologies	

I request the following devices be considered eligible for reimbursement under the Federal-aid highway program.

[Help](#)

System Type	Submission Type	Device Name / Variant	Testing Criterion	Test Level
'SS': Breakaway Sign Supports, Mailboxes, & other small sign supports	<input checked="" type="radio"/> Physical Crash Testing <input type="radio"/> FEA & V&V Analysis	Centerline Supply Triangular Slipbase Locking Sign Collar Assembly	NCHRP Report 350	TL3

By submitting this request for review and evaluation by the Federal Highway Administration, I certify that the product(s) was (were) tested in conformity with the NCHRP Report 350 (Report 350) and that the evaluation results meet the appropriate evaluation criteria in the Report 350.

Identification of the individual or organization responsible for the product:

Contact Name:	Foy Barrett	Same as Submitter <input type="checkbox"/>
Company Name:	Centerline Supply, LTD	Same as Submitter <input type="checkbox"/>
Address:	530 Jesse Street; Grand Prairie, TX 75051	Same as Submitter <input type="checkbox"/>
Country:	USA	Same as Submitter <input type="checkbox"/>

### PRODUCT DESCRIPTION

<input type="radio"/> New Hardware	<input checked="" type="radio"/> Modification to Existing Hardware	Non-Significant - Effect is positive or Inconsequential
<p>The Centerline Supply Triangular Slipbase Locking Sign Collar Assembly uses the same crashworthiness design principles of the omni-directional, triangular three-bolt slipbase commonly referred to as a the "Texas Triangular Slipbase". The modification to this basic design uses a tapered locking collar to secure the 2.875" outside diameter sign support. The locking action resulting from the collar's contact around the entire circumference of sign support minimizes the potential for the sign support and attached signs to rotate during strong wind conditions. This is a problem with many of the other previously approved triangular slipbase upper castings which use set-bolts to prevent support rotation. The raw material used is 65-45-12 Ductile Cast Iron (ASTM A536). The assembly weighs approximately 11.9 lbs. The three- 5/8" diameter triangular slipbase bolts are to be tightened to 40 foot-pounds. The two- 5/8" diameter locking collar bolts are to be tightened to 60 foot-pounds.</p>		

### CRASH TESTING

A brief description of each crash test and its result:

## Request for Federal Aid Reimbursement Eligibility Of Highway Safety Hardware

<b>Submitter</b>	Date of Request:	May 15, 2013	<input checked="" type="radio"/> New <input type="radio"/> Resubmission
	Name:	Gregory R. Brinkmeyer, P.E.	Signature:
	Company:	Hori-Zone Concepts LLC	
	Address:	14417 Chandler Road; Taylor, TX 76574	
	Country:	USA	
	To:	Michael S. Griffith, Director FHWA, Office of Safety Technologies	

I request the following devices be considered eligible for reimbursement under the Federal-aid highway program.

System Type	Submission Type	Device Name / Variant	Testing Criterion	Test Level
'SS': Breakaway Sign Supports, Mailboxes, & other small sign supports	<input checked="" type="radio"/> Physical Crash Testing <input type="radio"/> FEA & V&V Analysis	Centerline Supply Triangular Slipbase Locking Sign Collar Assembly	NCHRP Report 350	TL3

By submitting this request for review and evaluation by the Federal Highway Administration, I certify that the product(s) was (were) tested in conformity with the NCHRP Report 350 (Report 350) and that the evaluation results meet the appropriate evaluation criteria in the Report 350.

Identification of the individual or organization responsible for the product:

Contact Name:	Foy Barrett	Same as Submitter <input type="checkbox"/>
Company Name:	Centerline Supply, LTD	Same as Submitter <input type="checkbox"/>
Address:	530 Jesse Street; Grand Prairie, TX 75051	Same as Submitter <input type="checkbox"/>
Country:	USA	Same as Submitter <input type="checkbox"/>

### PRODUCT DESCRIPTION

Modification to Existing Hardware null
<p>The Centerline Supply Triangular Slipbase Locking Sign Collar Assembly uses the same crashworthiness design principles of the omni-directional, triangular three-bolt slipbase commonly referred to as a the "Texas Triangular Slipbase" (as described in NCHRP Web-Only Document 157). The modification to this approved basic design consist of using a tapered locking collar to secure the 2.875" outside diameter sign support into the upper slipbase casting. The locking action resulting from the collar's contact around the entire circumference of the sign support minimizes the potential for the sign support and attached signs to rotate during strong wind conditions. This is an identified field installation problem with many of the other previously approved triangular slipbase upper castings which use set-bolts to prevent support rotation. The raw material used is 65-45-12 Ductile Cast Iron (ASTM A536). The assembly weighs approximately 11.9 lbs. The three- 5/8" diameter triangular slipbase bolts are to be tightened to 40 foot-pounds. The two- 5/8" diameter locking collar bolts are to be tightened to 60 foot-pounds. Please see attached drawings and photos for additional details.</p>



## CRASH TESTING

A brief description of each crash test and its result:

Required Test Number	Narrative Description	Evaluation Results
3-60 (820C)		WAIVER REQUESTED
S3-60 (700C)		WAIVER REQUESTED
3-61 (820C)		WAIVER REQUESTED
S3-61 (700C)		WAIVER REQUESTED

Full Scale Crash Testing was done in compliance with Report 350 by the following accredited crash test laboratory (cite the laboratory's accreditation status as noted in the crash test reports.):

Laboratory Name:		
Laboratory Contact:		Same as Submitter <input type="checkbox"/>
Address:		Same as Submitter <input type="checkbox"/>
Country:		Same as Submitter <input type="checkbox"/>
Accreditation Certificate Number and Date:		

## ATTACHMENTS

Attach to this form:

- 1) A copy of the full test report, video, and a Test Data Summary Sheet for each test conducted in support of this request.
- 2) A drawing or drawings of the device(s) that conform to the Task Force-13 Drawing Specifications [[Hardware Guide Drawing Standards](#)]. For proprietary products, a single isometric line drawing is usually acceptable to illustrate the product, with detailed specifications, intended use, and contact information provided on the reverse. Additional drawings (not in TF-13 format) showing details that are key to understanding the performance of the device should also be submitted to facilitate our review.

FHWA Official Business Only:

Eligibility Letter		AASHTO TF13	
Number	Date	Designator	Key Words
SS-179	June 17, 2013	N/A	Breakaway Slip Base Sign Support

**Hori-Zone Concepts LLC**  
**Gregory R. Brinkmeyer, P.E.**

14417 Chandler Road Taylor, Texas 76574  
(512) 217-2580  
E-mail: gregory.brinkmeyer@att.net

Mr. Nick Artimovich  
FHWA Office of Safety  
1200 New Jersey Ave. S.E.  
Washington, D.C. 20590

### **Centerline Supply Locking Sign Collar Assembly**

Mr. Artimovich:

Per our conversation yesterday, on behalf of Centerline Supply, I am submitting this request for Federal Aid Reimbursement Eligibility of Highway Safety Hardware for the subject component of a Breakaway Sign Support System.

As you can see from the photos below, the basic slipbase characteristics of this upper triangular slipbase casting are identical to what is commonly referred to as the "Texas Triangular Slipbase" (as described in NCHRP Web-Only Document 157 *Volume I: Evaluation of Existing Roadside Safety Hardware Using Updated Criteria-Technical Report*).

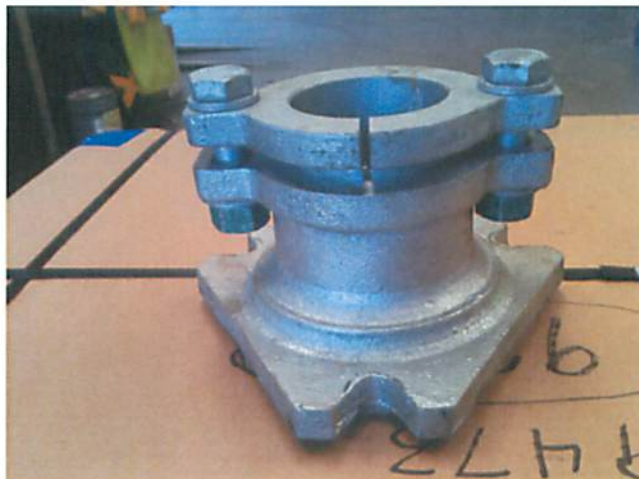

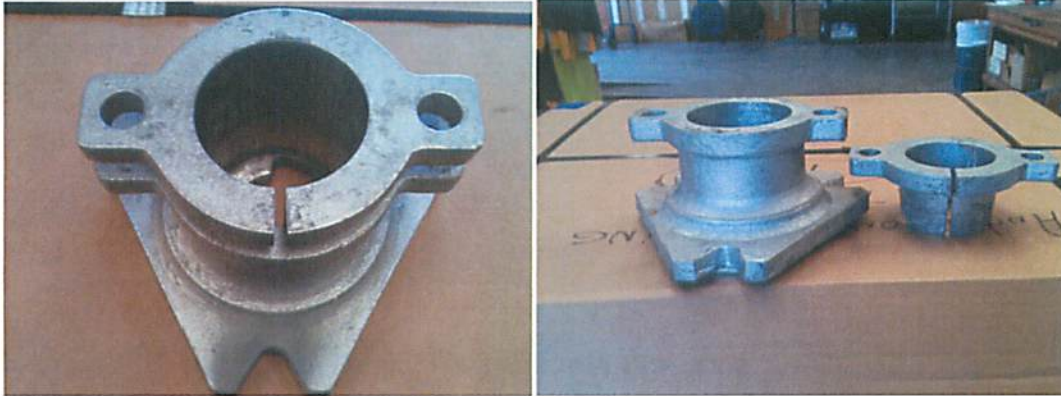

The Centerline Supply modification to the basic triangular slipbase design consists of using a tapered locking collar to secure the 2.875" outside diameter sign support post into the upper slipbase casting. As you are aware, other approved designs use set bolts installed through the upper casting wall to make contact with the sign support post. In windy conditions, sign post using the set bolt design rotate, resulting in sign messages no longer being legible to road users. The locking action of Centerline Supply Triangular Slipbase Locking Collar assembly makes surface contact with the entire circumference of the sign support post minimizing the potential for sign rotation.

The raw material used for this upper casting is 65-45-12 Ductile Cast Iron (ASTM A536). The assembly weights approximately 11.9 lbs. The three- 5/8" diameter triangular slipbase bolts are to be tightened to 40 foot-pounds. The two-5/8" diameter locking collar bolts are to be tightened to 60 foot-pounds.

Attached with this email submission are the detail drawings and the "Request for Federal Aid Reimbursement Eligibility of Highway Safety Hardware" form.

If you have any questions, please contact me at (512) 217-2580 or [gregory.brinkmeyer@att.net](mailto:gregory.brinkmeyer@att.net). We appreciate your time and effort in reviewing this submittal.

Sincerely,

/S/

Submitted Electronically

Gregory R. Brinkmeyer, P.E.  
Hori-Zone Concepts LLC  
Texas Firm Registration Number F-9512

**Hori-Zone Concepts LLC**  
**Gregory R. Brinkmeyer, P.E.**

14417 Chandler Road Taylor, Texas 76574  
(512) 217-2580  
E-mail: gregory.brinkmeyer@att.net

Mr. Nick Artimovich  
FHWA Office of Safety  
1200 New Jersey Ave. S.E.  
Washington, D.C. 20590

**Centerline Supply Locking Sign Collar Assembly**

Mr. Artimovich:

Per our conversation yesterday, on behalf of Centerline Supply, I am submitting this request for Federal Aid Reimbursement Eligibility of Highway Safety Hardware for the subject component of a Breakaway Sign Support System.

As you can see from the photos below, the basic slipbase characteristics of this upper triangular slipbase casting are identical to what is commonly referred to as the "Texas Triangular Slipbase" (as described in NCHRP Web-Only Document 157 *Volume I: Evaluation of Existing Roadside Safety Hardware Using Updated Criteria-Technical Report*).





The Centerline Supply modification to the basic triangular slipbase design consists of using a tapered locking collar to secure the 2.875" outside diameter sign support post into the upper slipbase casting. As you are aware, other approved designs use set bolts installed through the upper casting wall to make contact with the sign support post. In windy conditions, sign post using the set bolt design rotate, resulting in sign messages no longer being legible to road users. The locking action of Centerline Supply Triangular Slipbase Locking Collar assembly makes surface contact with the entire circumference of the sign support post minimizing the potential for sign rotation.

The raw material used for this upper casting is 65-45-12 Ductile Cast Iron (ASTM A536). The assembly weights approximately 11.9 lbs. The three- 5/8" diameter triangular slipbase bolts are to be tightened to 40 foot-pounds. The two-5/8" diameter locking collar bolts are to be tightened to 60 foot-pounds.

Attached with this email submission are the detail drawings and the "Request for Federal Aid Reimbursement Eligibility of Highway Safety Hardware" form.

If you have any questions, please contact me at (512) 217-2580 or [gregory.brinkmeyer@att.net](mailto:gregory.brinkmeyer@att.net). We appreciate your time and effort in reviewing this submittal.

Sincerely,

/S/

Submitted Electronically

Gregory R. Brinkmeyer, P.E.  
Hori-Zone Concepts LLC  
Texas Firm Registration Number F-9512

ECN	LTR	REVISIONS	DATE/INITIALS
	A	REDESIGN SLIP BASE	4-25-13

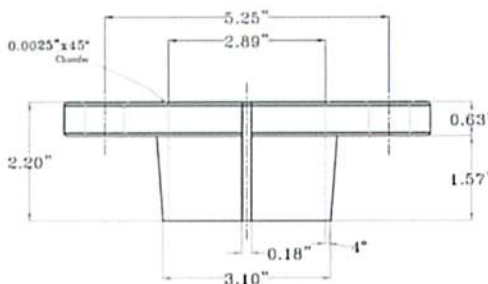
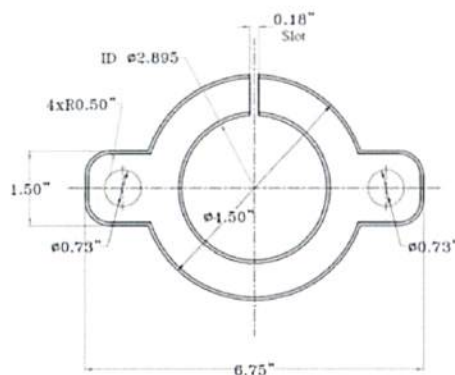
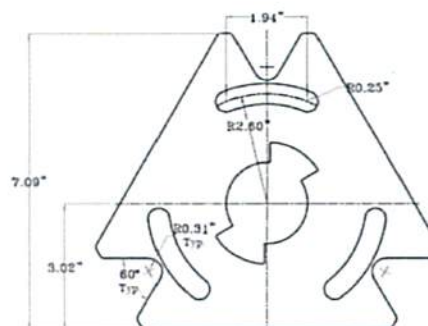
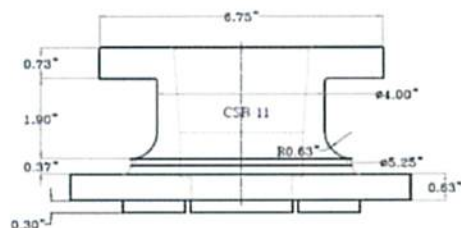
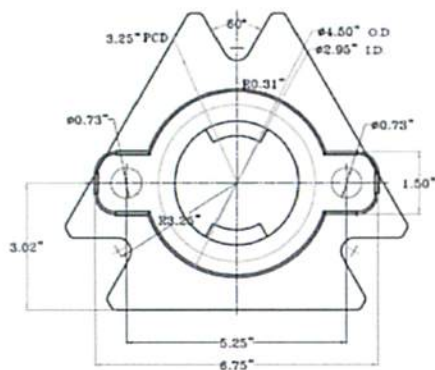

NOTE:  
NUT-BOLT WITH WASHER  
5/8 Ø 2.5 INCHES LONG  
A325

CONFIDENTIAL-PROPRIETARY  
THIS DRAWING IS THE PROPERTY OF  
E.L.S. MFG. AND IS SUBJECT TO  
RETURN UPON REQUEST. THE DRAWING  
INCLUDES CONFIDENTIAL AND PROPRIETARY  
INFORMATION OF E.L.S. MFG. AND IS  
LEADED IN CONFIDENCE WITH THE UNDER-  
STANDING THAT IT IS NOT TO BE COPIED  
OR REPRODUCED WITHOUT EXPRESS WRITER  
PERMISSION, AND THAT NEITHER THE  
DRAWING NOR INSTRUMENTATION HEREIN BE  
USED ADVERSELY TO E.L.S. MFG.  
ALL PATENT RIGHTS ARE RESERVED.  
—DO NOT SCALE DRAWING—

FINISH:  
NONE  
TOLERANCES UNLESS  
NOTED:  
X/X = +/- 1/16"  
XX = +/- 0.060  
XXX = +/- 0.030  
XXXX = +/- 0.010  
ANGULAR = +/- 1/2°

PROPERTY OF  
**CENTERLINE SUPPLY**  
530 JESSE ST GRAND PRAIRIE TX 75051

DRAWING NO. CSB-11 TITLE LOCKING SIGN COLLAR ASSEMBLY

RAW MTL: 65-45-12 DUCTILE CAST IRON, ASTM A536  
QTY/ASSY 1 EST. WT: 11.91 LBS

Drawn by: E.S. Date: 4-25-13 Sheet 1-1 Revision B Dimensions are inches