



U.S. Department
of Transportation
**Federal Highway
Administration**

1200 New Jersey Ave., S.E.
Washington, DC 20590

December 6, 2007

In Reply Refer To:
HSSD/SS-156

Mr. Jim Anderson
Designovations, Inc.
7339 Wildwood Road
Stillman Valley, IL 61084

Dear Mr. Anderson:

This letter is in response to your August 8, 2007, correspondence requesting the Federal Highway Administration's (FHWA) acceptance of your company's three SNAP'n SAFE breakaway sign support couplers as the National Cooperative Highway Research Program (NCHRP) Report 350 Test Level 3 (TL-3) devices. The three devices are: (1) the SNAP'n SAFE Round Surface Mount Breakaway Coupler, (2) the SNAP'n SAFE U-Channel Surface Mount Breakaway Coupler, and (3) the SNAP'n SAFE U-Channel In Ground Breakaway Coupler. To support your request, you provided the Texas Transportation Institute (TTI) test report "Pendulum Testing of the Designovations Small Sign Support Breakaway Couplers" dated August 3, 2007.

Requirements

Sign supports should meet the guidelines contained in the NCHRP Report 350, "Recommended Procedures for the Safety Performance Evaluation of Highway Features." The FHWA Memorandum "ACTION: Identifying Acceptable Highway Safety Features" of July 25, 1997, provides further guidance on crash testing requirements of sign supports and on the use of low-speed pendulum tests as a surrogate for full-scale crash testing.

Product description

All of SNAP'n SAFE breakaway couplers are made from cast iron. The couplers are designed to break off at any impact angle. The SNAP'n SAFE Round Surface Mount Breakaway Coupler is used with 2-3/8 inch (60.3 mm) diameter round sign supports with wall thicknesses of 16 gauge (thin wall) up to and including 8 gauge (heavy wall). The SNAP'n SAFE U-Channel Surface Mount and In Ground Breakaway Coupler can be used with 2 lb, 2-1/2 lb, 3 lb, and 4 lb (0.91 kg, 1.13 kg, 1.36 kg, 1.81 kg respectively) U-channel posts. The design details of SNAP'n SAFE breakaway couplers are enclosed.

MOVING THE
AMERICAN
ECONOMY 

Testing

The NCHRP Report 350 criteria for sign supports to meet TL-3 suggests they must successfully pass tests 3-60 and 3-61. These tests involve an 820 kg passenger car impacting the support head-on at the critical impact angle, at a speed of 35 km/h (test 3-60) and 100 km/h (test 3-61).

Alternatively, tests with pendulums are acceptable for most breakaway supports with the exceptions of base bending or yielding supports.

The following three pendulum tests were conducted to verify the performance of the couplers:

1. The SNAP'n SAFE Round Surface Mount Breakaway Coupler was mounted on a steel reaction plate and tested with a 2-3/8 inch (60.3 mm) diameter by 10 feet (3.0 m) tall thin wall round sign post. A 36 inch by 1/8 inch thick (914 mm x 3.2 mm) octagonal metal sign was mounted on the sign post placed on a 7 inch (178 mm) diameter casting, with height to the bottom of the sign panel at 7 feet (2.1 m). This sign post is the lightest in the range of sign posts which can be used with the coupler. It was anticipated that if this test is passed, the system will also perform acceptably with the heavier wall sign posts.
2. The SNAP'n SAFE U-Channel Surface Mount Breakaway Coupler was mounted on a steel reaction plate and tested with 2lb (0.91 kg) perforated U-channel post placed on a 7 inch (178 mm) diameter casting with 3-1/4 in (82.6 mm) stub. A 36 inch by 1/8 inch thick (914 mm x 3.2 mm) octagonal metal sign was mounted on the sign post with height to the bottom of the sign panel at 7 feet (2.1 m). This sign post is the lightest in the range of U-channels which can be used with the coupler. It was anticipated that if this test is passed, the system will also perform acceptably with the heavier U-channel sign posts.
3. The SNAP'n SAFE U-Channel In Ground Breakaway Coupler was mounted on the in-ground stub embedded 4 feet (1.2 m) in weak soil and tested with the 2 lb (0.91 kg) perforated U-channel post. A 36 inch by 1/8 inch thick (914 mm x 3.2 mm) octagonal metal sign was mounted on the sign post with height to the bottom of the sign panel at 7 feet (2.1 m). This post is the lightest in the range of U-channels which can be used with the coupler. It was anticipated that if this test is passed, the system will also perform acceptably with the heavier U-channel sign posts and in standard soils.

In addition, TTI extrapolated the high speed performance from the low speed pendulum tests. We agree that the test articles appear to perform appropriately to make such high speed extrapolations. The high speed extrapolations yielded equivalent or lower change in velocity values than the paired low speed pendulum tests.

We agree that the above tests are the most critical for your company's SNAP'n SAFE breakaway couplers and that successful performance in these tests indicates that the device should also perform acceptably with heavier sign posts. According to the information you provided, all three tests were successful in that the three SNAP'n SAFE breakaway sign support couplers met all of the applicable NCHRP 350 evaluation criteria. In the conducted tests the support separated from the base as designed. No intrusion into the occupant compartment occurred, and the maximum change in vehicle velocity was less than the permitted maximum limit of 16 ft/s (4.88 m/s). Extrapolations from low-speed pendulum tests to high speed performance conducted by TTI have shown that the maximum change in velocity will likely be lower than indicated in all conducted pendulum tests. A summary of the test results is enclosed.

The damage sustained by the test articles was as follows:

- In the test with the Round Surface Mount Breakaway Coupler, the casting fractured at 3/4 inches (19 mm) inside the pipe support.
- In the test with the SNAP'n SAFE U-Channel Surface Mount Breakaway Coupler, the casting broke at the bottom of the stub.
- In the test with the SNAP'n SAFE U-Channel In Ground Breakaway Coupler, the support broke at the base of the stub and the stub was twisted 30 degrees. The U-Channel was deformed and twisted at 16 inches (406 mm) above the lower end. The U-Channel support and sign panel came to rest 30 feet (9.1 m) downstream of impact.

In summary, we agree that the three SNAP'n SAFE Breakaway Couplers as described above meet the appropriate evaluation criteria for NCHRP 350 TL-3 devices, and may be used with small sign supports at all appropriate locations on the NHS when selected by the contracting authority, subject to the provisions of Title 23, Code of Federal Regulations, Section 635.411, as they pertain to proprietary products. Please note that this acceptance is based on the reported crash performance of the couplers and is not meant to address their installation, maintenance or repair characteristics.

Standard provisions

Please note the following standard provisions that apply to the FHWA letters of acceptance:

- Our acceptance is limited to the crashworthiness characteristics of the devices and does not cover their structural features, nor conformity with the Manual on Uniform Traffic Control Devices.
- Any changes that may adversely influence the crashworthiness of the device will require a new acceptance letter.
- Should the FHWA discover that the qualification testing was flawed, that in-service performance reveals unacceptable safety problems, or that the device being marketed is significantly different from the version that was crash tested, it reserves the right to modify or revoke its acceptance.
- You will be expected to supply potential users with sufficient information on design and installation requirements to ensure proper performance.
- You will be expected to certify to potential users that the hardware furnished has essentially the same chemistry, mechanical properties, and geometry as that submitted for acceptance, and that they will meet the crashworthiness requirements of the FHWA and the NCHRP Report 350.
- To prevent misunderstanding by others, this letter of acceptance, designated as number SS-156, shall not be reproduced except in full. This letter, and the test documentation upon which this letter is based, is public information. All such letters and documentation may be reviewed at our office upon request.

This acceptance letter shall not be construed as authorization or consent by the FHWA to use, manufacture, or sell any patented device for which the applicant is not the patent holder. The acceptance letter is limited to the crashworthiness characteristics of the candidate device, and the

FHWA is neither prepared nor required to become involved in issues concerning patent law. Patent issues, if any, are to be resolved by the applicant.

Sincerely yours,



George E. Rice, Jr.
Acting Director, Office of Safety Design
Office of Safety

Enclosure

~~FHWA:HSSD:MLupes:tb:x66994:11/26/07~~

~~File: s://directory folder/mlupes/SS156-Designovations.doc~~

~~cc: HSSD (Reader, HSA, Chron File, HSSD; M.Lupes, HSSD;
M.Bloschock, HSSD; M.McDonough, HSSD)~~

APPENDIX C. DETAILS OF TEST ARTICLES

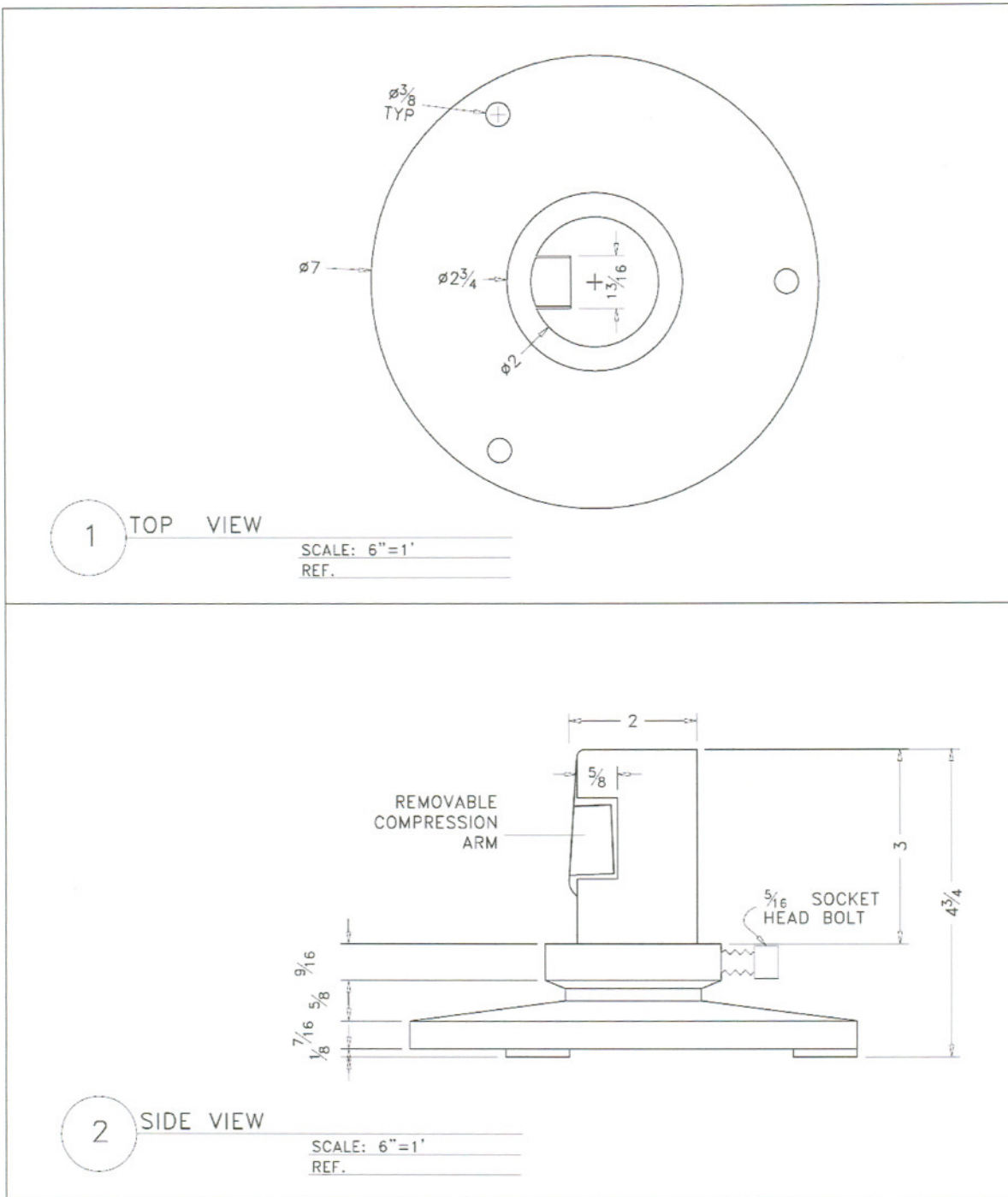

DRW. D-1

Surface Round Breakaway Coupler
 Ground Application - $2\frac{3}{8}$ " Diam. Steel Post
 ASTM A48 Grey Iron Class 35 Scale: 6"=1'
 Drawing Property of Designations, Inc. 04/07

C:\Program Files\Working\designations\surface round3rev.dwg, 6/4/2007 6:45:38 PM, Adobe PDF

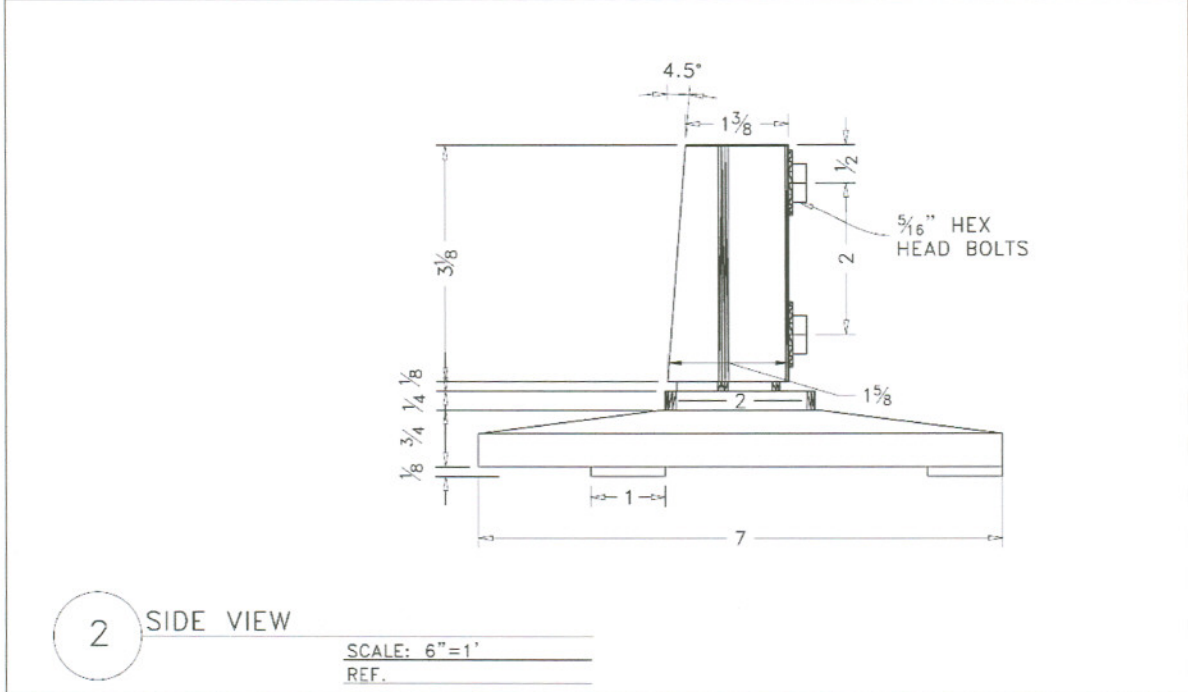
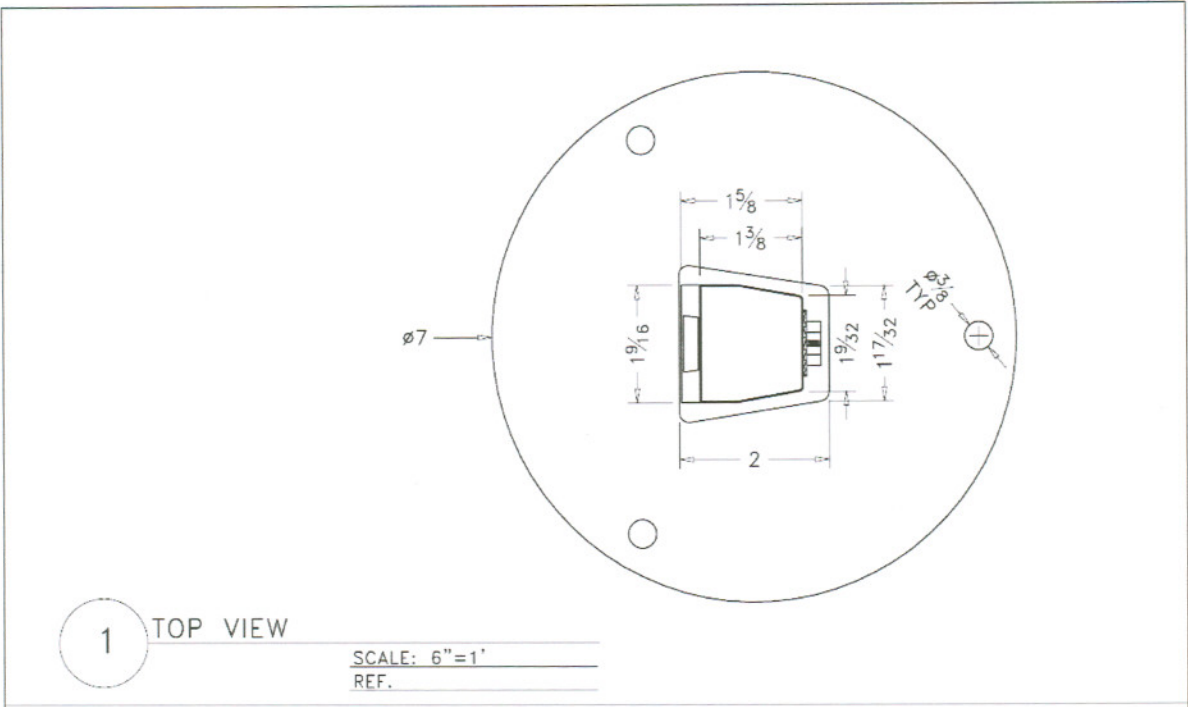

Surface U-Channel Breakaway Coupler
 Application- U-Channel Steel Post
 ASTM A48 Grey Iron Class 35 Scale: 6"=1'
 Drawing Property of Designovations, Inc. 04/07

DRW. D-2

C:\Program Files\Working\designovations\surface round3rev.dwg, 6/4/2007 6:44:47 PM, Adobe PDF

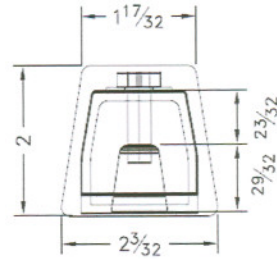

1 TOP AND BOTTOM VIEW
 SCALE: 6"=1'
 REF.

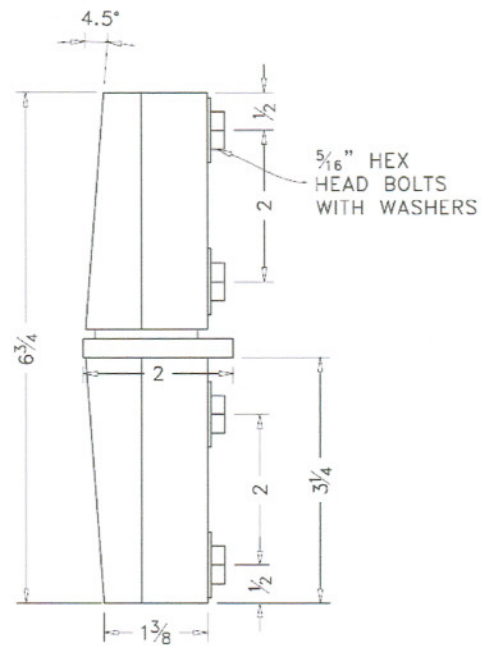

2 SIDE VIEW
 SCALE: 6"=1'
 REF.

U-Channel Breakaway Coupler
 Application- U-Channel Steel Post
 ASTM A48 Grey Iron Class 35 Scale: 6"=1'
 Drawing Property of Designovations, Inc. 04/07

DRW. D-3

C:\Program Files\Working\designovations\surface round3rev.dwg, 6/4/2007 6:43:51 PM, Adobe PDF

Table D1. Summary of results for pendulum test 400001-DES P9.

<p>0.000 s</p>	<p>General Information Test Agency Texas Transportation Institute Test No. 400001-DES P9 Date 06-11-2007</p>
<p>0.024 s</p>	<p>Test Article Type Single Small Sign Support Breakaway Coupler Name Designovations Breakaway Couplers Installation Height (m) 7 ft Material of Key Element 2-3/8-inch OD thin wall on 7-inch diameter casting</p>
<p>0.073 s</p>	<p>Soil Type Metal Reaction Plate</p> <p>Test Vehicle Type Bogie Designation Pendulum Test Inertia Mass 1850 lb</p>
<p>0.147 s</p>	<p>Impact Conditions Speed 21.7 mi/h Angle 90 deg</p> <p>Occupant Risk Values Impact Velocity Longitudinal direction No contact Ridedown Accelerations Longitudinal direction N/A</p> <p>Maximum change in Velocity 1.3 ft/s Predicted High-Speed Change in Velocity 1.0 ft/s</p>

Table D2. Summary of results for pendulum test 400001-DES P10.

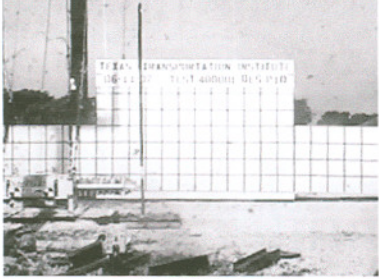
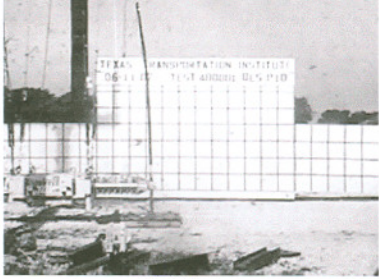
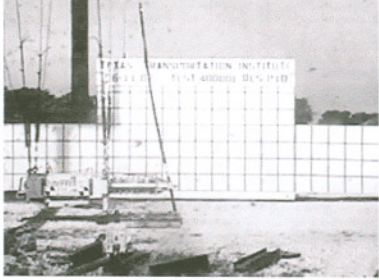
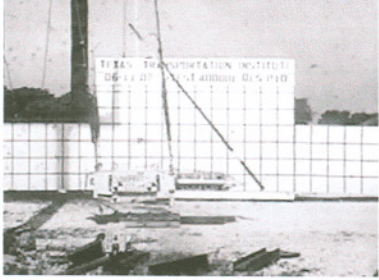
 <p>0.000 s</p>	<p>General Information Test Agency..... Texas Transportation Institute Test No..... 400001-DES P10 Date..... 06-11-2007</p>
 <p>0.024 s</p>	<p>Test Article Type..... Single Small Sign Support Breakaway Coupler Name..... Designovations Breakaway Couplers Installation Height (m)..... 7 ft Material of Key Element 2-lb Perforated U-Channel on 7-inch diameter casting</p>
 <p>0.073 s</p>	<p>Soil Type..... Metal Reaction Plate</p> <p>Test Vehicle Type..... Bogie Designation..... Pendulum Test Inertia Mass 1850 lb</p> <p>Impact Conditions Speed 21.6 mi/h Angle 90 deg</p>
 <p>0.147 s</p>	<p>Occupant Risk Values Impact Velocity Longitudinal direction..... No contact Ridedown Accelerations Longitudinal direction..... N/A</p> <p>Maximum change in Velocity 0.8 ft/s Predicted High-Speed Change in Velocity 1.0 ft/s</p>

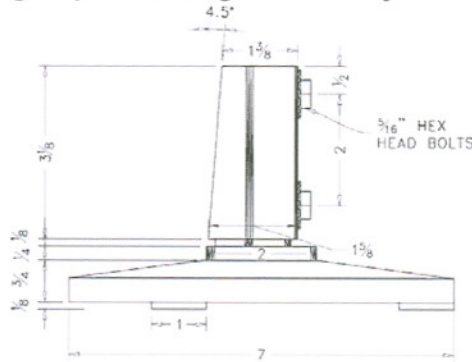
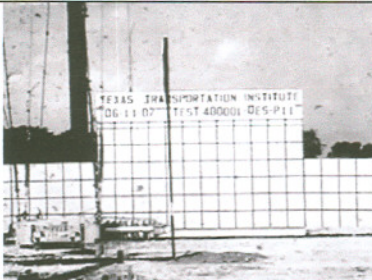
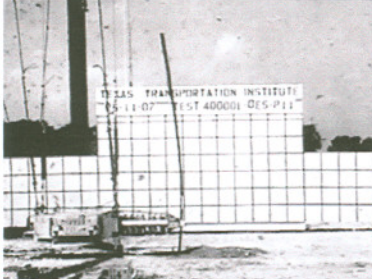
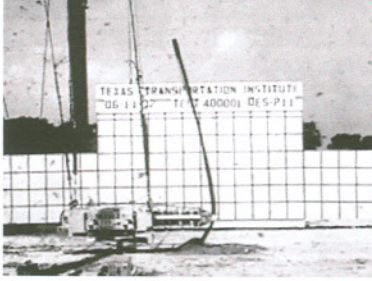
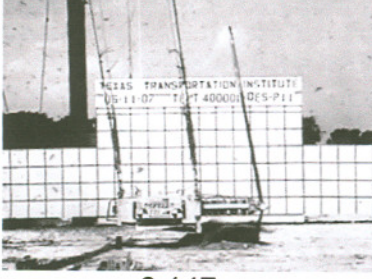

Table D3. Summary of results for pendulum test 400001-DES P11.

 <p>0.000 s</p>	<p>General Information Test Agency..... Texas Transportation Institute Test No. 400001-DES P11 Date 06-11-2007</p>
 <p>0.024 s</p>	<p>Test Article Type..... Single Small Sign Support Breakaway Coupler Name Designovations Breakaway Couplers Installation Height (m)..... 7 ft Material of Key Element 2-lb Perforated U-Channel in stub embedded 4 ft</p>
 <p>0.073 s</p>	<p>Soil Type..... Weak Soil</p> <p>Test Vehicle Type..... Bogie Designation..... Pendulum Test Inertia Mass 1850 lb</p> <p>Impact Conditions Speed 21.9 mi/h Angle 90 deg</p>
 <p>0.147 s</p>	<p>Occupant Risk Values Impact Velocity Longitudinal direction..... No contact Ridedown Accelerations Longitudinal direction..... N/A</p> <p>Maximum change in Velocity 4.1 ft/s Predicted High-Speed Change in Velocity 2.0 ft/s</p> 