

April 1, 2004

Refer to: HSA-10/SS-123

Mr. Jim Anderson
Designovations, Inc.
339 Wildwood Road
Stillman Valley, Illinois 61084

Dear Mr. Anderson:

Thank you for your letter of February 12, 2003, requesting Federal Highway Administration (FHWA) acceptance of your company's SNAP'n SAFE™ breakaway system for square sign supports for use on the National Highway System (NHS). Accompanying your letter was a report from the Texas Transportation Institute and videos of the crash tests. You requested that we find acceptable for use on the NHS under the provisions of National Cooperative Highway Research Program (NCHRP) Report 350 "Recommended Procedures for the Safety Performance Evaluation of Highway Features."

Introduction

Testing of the supports was in compliance with the guidelines contained in the NCHRP Report 350, Recommended Procedures for the Safety Performance Evaluation of Highway Features. Requirements for breakaway supports are those in the American Association of State Highway and Transportation Officials' Standard Specifications for Structural Supports for Highway Signs, Luminaires and Traffic Signals.

The Designovations, Inc., Break-Away device is a cast iron frangible coupling connecting a ground stub and the sign post. The coupler fractures upon impact at a predetermined scored line in the coupling, releasing the sign post from the ground stub. The coupler, shown in the attached drawing for reference, is fabricated of ASTM A48 gray iron, class 35. The coupler has a score 1/32 inch deep by 1/32 inch wide around its perimeter. This letter deals with the smaller coupler designed for a 2 inch composite post or a 1.75 inch perforated square steel post.

Testing

Two versions of a sign support using the coupler were crash tested. The first, test DES P1, used a 2 inch UniStrut perforated square steel tube sign post with a 2.25 inch UniStrut ground stub inserted in weak soil. The top portion of the coupler measured 1.75 inches on a side. The second test, DES P2, the stub conditions were the same, but the coupler supported a 2.0 inch fiberglass composite post with a 0.25 inch wall thickness. The top of the coupler in the second test measured 1.50 inches on a side. In both tests, a 36-inch octagonal aluminum sign panel was bolted at a mounting height of 84.5 inches.

Test #	Speed	Version	Article	Occup. Speed	Delta V
1 400001-DES P1	35.0 km/hr	1.75 inch top	PSST	None	1.67 m/s
2 400001-DES P2	35.2 km/hr	1.50 inch top	Fiberglass	None	0.64 m/s

Occup. Speed: Occupant Impact Speed: Speed at which a theoretical front seat occupant will contact the windshield. In meters per second.

Delta V: Speed change of the test vehicle. In meters per second.

Findings

In both tests the stubs moved through the weak soil and deformed below the ground line, but the coupler still sheared as designed. Velocity changes and decelerations were all within acceptable limits. There were no appreciable remains of the coupler left to protrude above the top of the stub, which had been installed such that the top of the stub would be at a height less than 4 inches above the ground. The results of testing met the FHWA requirements and, therefore, the SNAP'n SAFE™ devices (2 inch composite posts and 1.75 inch perforated square steel posts) described above and shown in the enclosed drawings for reference are acceptable for use as Test Level 3 devices on the NHS under the range of conditions tested, when proposed by a State.

Please note the following standard provisions that apply to the FHWA letters of acceptance:

- Our acceptance is limited to the crashworthiness characteristics of the devices and does not cover their structural features, nor conformity with the Manual on Uniform Traffic Control Devices.
- Any changes that may adversely influence the crashworthiness of the device will require a new acceptance letter.
- Should the FHWA discover that the qualification testing was flawed, that in-service performance reveals unacceptable safety problems, or that the device being marketed is significantly different from the version that was crash tested, it reserves the right to modify or revoke its acceptance.
- You will be expected to supply potential users with sufficient information on design and installation requirements to ensure proper performance.
- You will be expected to certify to potential users that the hardware furnished has essentially the same chemistry, mechanical properties, and geometry as that submitted for acceptance, and that they will meet the crashworthiness requirements of the FHWA and the NCHRP Report 350.
- To prevent misunderstanding by others, this letter of acceptance, designated as number SS-123 shall not be reproduced except in full. As this letter and the supporting documentation which support it become public information, it will be available for inspection at our office by interested parties.
- The Designovations, Inc., SNAP'n SAFE™ Device is a patented product and is considered "proprietary." When proprietary devices are *specified by a highway agency* for use on Federal-aid projects they: (a) must be supplied through competitive bidding with equally suitable unpatented items; (b) the highway agency must certify that they are essential for synchronization with existing highway facilities or that no equally suitable

alternative exists or; (c) they must be used for research or for a distinctive type of construction on relatively short sections of road for experimental purposes. These provisions do not apply to exempt non-NHS projects. Our regulations concerning proprietary products are contained in Title 23, Code of Federal Regulations, Section 635.411, a copy of which is enclosed.

- This acceptance letter shall not be construed as authorization or consent by the FHWA to use, manufacture, or sell any patented device. Patent issues are to be resolved by the applicant and the patent owner.

Sincerely yours,

/Original Signed By Harry Taylor/

for: John R. Baxter, P.E.
Director, Office of Safety Design
Office of Safety

Enclosures

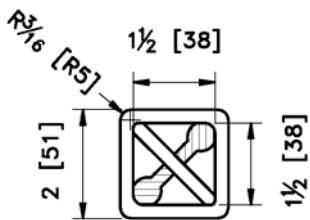

TOP SECTION VIEW

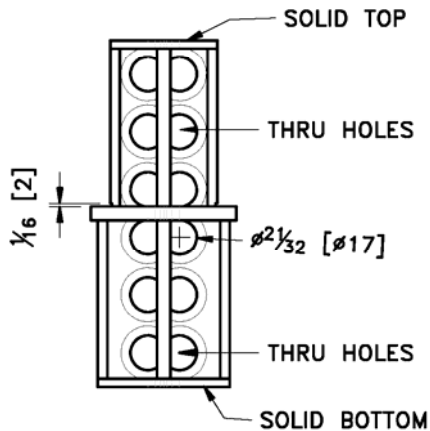

FRONT ROTATED 45°

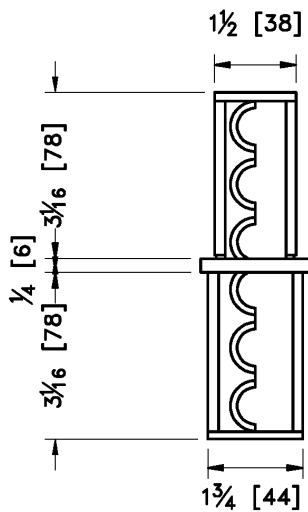

FRONT VIEW

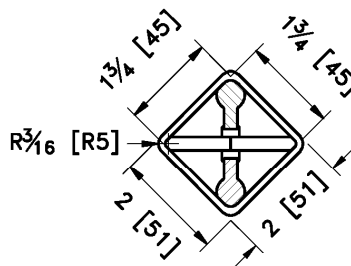

BOTTOM ROTATED 45°

2008

SNAP'n SAFE SQUARE BREAKAWAY COUPLER



DESIGNOVATIONS, INC.

7339 WILDWOOD ROAD • STILLMAN VALLEY, IL 61084
 PHONE: 888-868-6588 • FAX: 815-645-2389
 EMAIL: sales@designovations.com • www.designovations.com

1 3/4"

SHEET NO.	REF. NO.
1 of 2	DV-017