



U.S. Department
of Transportation
**Federal Highway
Administration**

1200 New Jersey Ave., SE
Washington, D.C. 20590

April 1, 2016

In Reply Refer To:
HSST/CC-78E

Mr. Bret Eckert P.E.
Engineering Applications Manager
Trinity Highway Products
3617 Cincinnati Avenue
Rocklin, CA 95677

Dear Mr. Eckert:

This letter is in response to your December 16, 2015 request for the Federal Highway Administration (FHWA) to review a roadside safety device, hardware, or system for eligibility for reimbursement under the Federal-aid highway program. This FHWA letter of eligibility is assigned FHWA control number CC-78E and is valid until a subsequent letter is issued by FHWA that expressly references this device.

Decision

The following devices are eligible, with details provided in the form which is attached as an integral part of this letter:

- SST TMA Modification

Scope of this Letter

To be found eligible for Federal-aid funding, modified roadside safety devices should meet the crash test and evaluation criteria contained in the National Cooperative Highway Research Program (NCHRP) Report 350. However, the FHWA, the Department of Transportation, and the United States Government do not regulate the manufacture of roadside safety devices. Eligibility for reimbursement under the Federal-aid highway program does not establish approval, certification or endorsement of the device for any particular purpose or use.

This letter is not a determination by the FHWA, the Department of Transportation, or the United States Government that a vehicle crash involving the device will result in any particular outcome, nor is it a guarantee of the in-service performance of this device. Proper manufacturing, installation, and maintenance are required in order for this device to function as tested.

This finding of eligibility is limited to the crashworthiness of the system and does not cover other structural features, nor conformity with the Manual on Uniform Traffic Control Devices.

Eligibility for Reimbursement

FHWA previously issued an eligibility letter for the roadside safety system described in your pending request. Your pending request now identifies a modification to that roadside safety system.

The original roadside safety device information is:

Name of system: SST TMA
Type of system: Crash Cushion
Date of original request: September 13, 1999
Date of original FHWA eligibility letter: June 15, 2005
FHWA Control number: CC-78C

The pending modification(s) consists of the following changes:

1. Created a version with a flat blade electrical plug to the truck
2. A new lighting kit was made available for Illinois Tollway

‘FHWA concurs with the recommendation of the accredited crash testing laboratory as stated within the attached form.’

Full Description of the Eligible Device

The device and supporting documentation, including reports of the crash tests or other testing done, videos of any crash testing, and/or drawings of the device, are described in the attached form.

Notice

If a manufacturer makes any modification to any of their roadside safety hardware that has an existing eligibility letter from FHWA, the manufacturer must notify FHWA of such modification with a request for continued eligibility for reimbursement. The notice of all modifications to a device must be accompanied by:

- Significant modifications – For these modifications, crash test results must be submitted with accompanying documentation and videos.
- Non-signification modifications – For these modifications, a statement from the crash test laboratory on the potential effect of the modification on the ability of the device to meet the relevant crash test criteria.

FHWA's determination of continued eligibility for the modified hardware will be based on whether the modified hardware will continue to meet the relevant crash test criteria.

You are expected to supply potential users with sufficient information on design, installation and maintenance requirements to ensure proper performance.

You are expected to certify to potential users that the hardware furnished has the same chemistry, mechanical properties, and geometry as that submitted for review, and that it will meet the test and evaluation criteria of the NCHRP Report 350.

Issuance of this letter does not convey property rights of any sort or any exclusive privilege. This letter is based on the premise that information and reports submitted by you are accurate and correct. We reserve the right to modify or revoke this letter if: (1) there are any inaccuracies in the information submitted in support of your request for this letter, (2) the qualification testing was flawed, (3) in-service performance or other information reveals safety problems, (4) the system is significantly different from the version that was crash tested, or (5) any other information indicates that the letter was issued in error or otherwise does not reflect full and complete information about the crashworthiness of the system.

Standard Provisions

- To prevent misunderstanding by others, this letter of eligibility designated as FHWA control number CC-78E shall not be reproduced except in full. This letter and the test documentation upon which it is based are public information. All such letters and documentation may be reviewed upon request.
- This letter shall not be construed as authorization or consent by the FHWA to use, manufacture, or sell any patented system for which the applicant is not the patent holder.
- If the subject device is a patented product it may be considered to be proprietary. If proprietary systems are specified by a highway agency for use on Federal-aid projects: (a) they must be supplied through competitive bidding with equally suitable unpatented items; (b) the highway agency must certify that they are essential for synchronization with the existing highway facilities or that no equally suitable alternative exists; or (c) they must be used for research or for a distinctive type of construction on relatively short sections of road for experimental purposes. Our regulations concerning proprietary products are contained in Title 23, Code of Federal Regulations, Section 635.411.

Sincerely yours,



Michael S. Griffith
Director, Office of Safety Technologies
Office of Safety

Enclosures

Request for Federal Aid Reimbursement Eligibility of Highway Safety Hardware

Submitter	Date of Request:	March 24, 2016	<input type="radio"/> New <input checked="" type="radio"/> Resubmission
	Name:	Bret R. Eckert, P.E.	
	Company:	Trinity Highway Products, LLC	
	Address:	3617 Cincinnati Ave., Rocklin, CA 95765	
	Country:	USA	
	To:	Michael S. Griffith, Director FHWA, Office of Safety Technologies	

I request the following devices be considered eligible for reimbursement under the Federal-aid highway program.

System Type	Submission Type	Device Name / Variant	Testing Criterion	Test Level
'CC': Truck-Mounted Attenuators (TMA)	<input type="radio"/> Physical Crash Testing <input checked="" type="radio"/> Engineering Analysis	SST [®] TMA	NCHRP Report 350	TL3

By submitting this request for review and evaluation by the Federal Highway Administration, I certify that the product(s) was (were) tested in conformity with the NCHRP Report 350 (Report 350) and that the evaluation results meet the appropriate evaluation criteria in the Report 350.

Identification of the individual or organization responsible for the product:

Contact Name:	Bret R. Eckert, P.E.	Same as Submitter <input checked="" type="checkbox"/>
Company Name:	Trinity Highway Products, LLC	Same as Submitter <input checked="" type="checkbox"/>
Address:	3617 Cincinnati Ave., Rocklin, CA 95765	Same as Submitter <input checked="" type="checkbox"/>
Country:	USA	Same as Submitter <input checked="" type="checkbox"/>

Enter below all disclosures of financial interests as required by the FHWA 'Federal-Aid Reimbursement Eligibility Process for Safety Hardware Devices' document.

The SST[®] TMA technology is the commercial embodiment of intellectual property that is protected by patents that are owned by Trinity Highway Products, LLC (THP). THP does not pay royalties for sales of the SST[®] TMA system. The SST[®] TMA system was designed and developed by engineers at Energy Absorption Systems Inc. (EAS). The patent holders of record for the SST[®] TMA system are Michael J. Buehler, Bret Eckert, and James B. Welch and were employed by EAS. The associated United States Patent Office patent numbers (7,874,572, 8,136,830, 8,388,012, & 8,556,286) are assigned to Energy Absorption Systems, Inc. / Trinity Industries, Inc.

EAS sponsored certain crash tests of the SST[®] TMA system; such tests were conducted by E-Tech Testing Services, an independent, wholly-owned subsidiary of THP. E-Tech Testing Services is an International Standards Organization ("ISO") 17025 accredited laboratory with American Association for Laboratory Accreditation (A2LA) Mechanical Testing certificate 989.01. Full-scale crash testing on the SST[®] TMA system was performed in accordance with testing criteria, as set forth by the National Cooperative Highway Research Program ("NCHRP") in the NCHRP Report 350 (1993).

PRODUCT DESCRIPTION

<input type="radio"/> New Hardware or Significant Modification	<input checked="" type="radio"/> Modification to Existing Hardware	<input type="radio"/> Non-Significant
<p>Original submission date December 22, 2015. The SST® Tow-able Mounted Attenuator (TMA) was originally accepted on June 15, 2005 with FHWA eligibility letter HSA-10/CC-78C as a NCHRP 350 TL-3 TMA. It was also accepted on July 25, 2007 with FHWA eligibility letter HSSD/CC-78D with an arrowboard. The SST® is a tow-behind version of the SS180 cantilevered TMA. It is comprised of a collapsible and typically reusable steel support frame around two lightweight aluminum energy absorbing cartridges with a delineated impact face. A hitch and an axle provide the tow-able features.</p> <p>This request for continued eligibility is to notify the FHWA of necessary revisions that have occurred since May 18, 2015. All revisions have been justified through engineering analysis and judgement and have been determined to be non-significant and will have no bearing on the as-tested performance of the system. These revisions include the following:</p> <ol style="list-style-type: none"> 1. Created a version with a flat blade electrical plug to the truck. (4051) 2. A new lighting kit was made available for Illinois Toll-way. (4136) 		

CRASH TESTING

A brief description of each crash test and its result:

Required Test Number	Narrative Description	Evaluation Results
3-50 (820C)	Test 3-50 for the SST® TMA system was waived in FHWA eligibility letter CC-78C as the SST® uses the same collapsible arms, impact frame, support frame and energy absorbing cartridges as the original SS180 TMA and the modifications and attachment details are unlikely to affect the test results previously submitted. The non-significant modifications described in the Product Description will have no bearing on the as-tested performance of the system.	PASS
S3-50 (700C)	Not Applicable. Test S3-50 is an optional test and not required for system eligibility.	
3-51 (2000P)	The SST® TMA system Test 3-51 was conducted and documented in Laboratory Test No. 01-5432-003, Date of Test April 26, 2007, in Test Report No. 254. The non-significant modifications described in the Product Description will have no bearing on the as-tested performance of the system.	PASS
3-52 (2000P)	The SST® TMA system Test 3-52 was conducted and documented in Laboratory Test No. 01-5432-001, Date of Test March 24, 2005, in Test Report No. 254. The non-significant modifications described in the Product Description will have no bearing on the as-tested performance of the system.	PASS
3-53 (2000P)	The SST® TMA system Test 3-53 was conducted and documented in Laboratory Test No. 01-5432-002, Date of Test June 2, 2005, in Test Report No. 254. The non-significant modifications described in the Product Description will have no bearing on the as-tested performance of the system.	PASS

Full Scale Crash Testing was done in compliance with NCHRP Report 350 by the following accredited crash test Laboratory. By signature below, the Laboratory agrees in support of this submission that all critical and relevant crash tests for the device listed above were conducted. (cite the laboratory's accreditation status as noted in the crash test reports.):

Testing Laboratory's signature concurs that these modifications are considered Non-Significant.		
Laboratory Name:	E-Tech Testing Services, Inc.	
Laboratory Signature:	Paul Kruse	Digitally signed by Paul Kruse Date: 2016.03.24 09:15:30 -07'00'
Address:	3617B Cincinnati Ave., Rocklin, CA 95765	Same as Submitter <input type="checkbox"/>
Country:	USA	Same as Submitter <input checked="" type="checkbox"/>
Accreditation Certificate Number and Dates of current Accreditation period :	A2LA Certificate# 989.01, November 20, 2015 to November 30, 2017	

Submitter Signature*: Bret Eckert P.E.

Digitally signed by
bret.eckert@trin.net
DN: cn=bret.eckert@trin.net
Date: 2016.03.24 15:20:06 -07'00'

Submit Form

ATTACHMENTS

Attach to this form:

- 1) Additional disclosures of related financial interest as indicated above.
- 2) A copy of the full test report, video, and a Test Data Summary Sheet for each test conducted in support of this request.
- 3) A drawing or drawings of the device(s) that conform to the Task Force-13 Drawing Specifications [[Hardware Guide Drawing Standards](#)]. For proprietary products, a single isometric line drawing is usually acceptable to illustrate the product, with detailed specifications, intended use, and contact information provided on the reverse. Additional drawings (not in TF-13 format) showing details that are relevant to understanding the dimensions and performance of the device should also be submitted to facilitate our review.

FHWA Official Business Only:

Eligibility Letter		AASHTO TF13	
Number	Date	Designator	Key Words

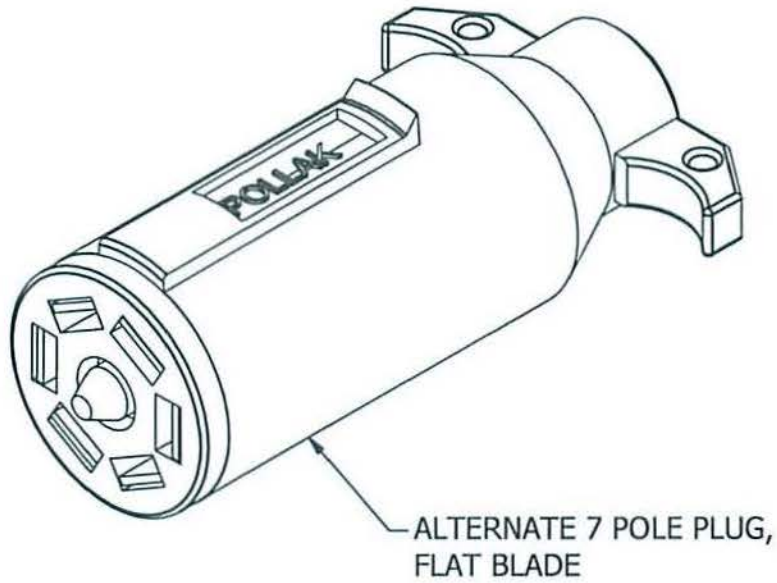
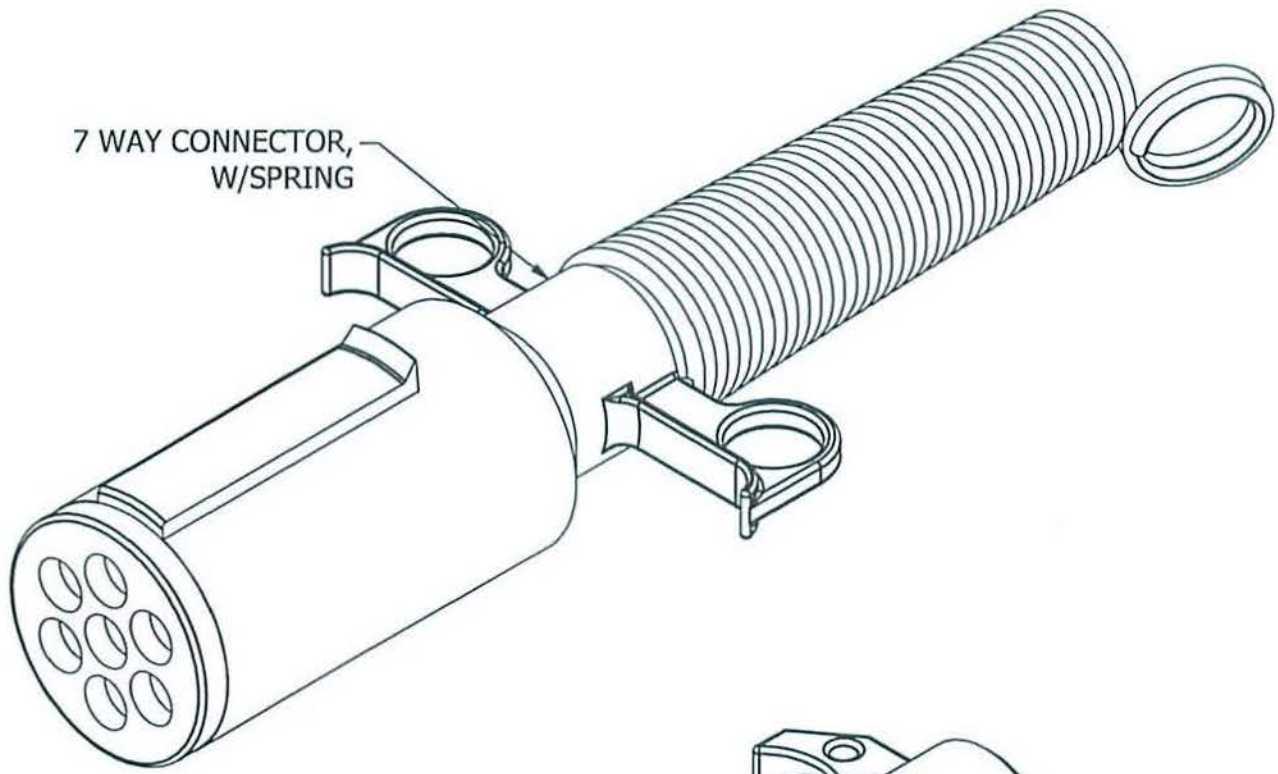

SST[®] TRAILER MOUNTED
ATTENUATOR
7-FLAT TRAILER PLUG

