

December 10, 2003

Refer to: HSA-10/CC-35F

Barry D. Stephens, P.E.
Senior Vice President of Engineering
Energy Absorption Systems, Incorporated
3617 Cincinnati Avenue
Rocklin, California 95765

Dear Mr. Stephens:

In your November 15, 2003, letter to Mr. Richard Powers of my staff, you requested formal Federal Highway Administration acceptance of a parallel-sided QuadGuard CZ mounted on a 42-inch wide A-36 steel plate anchored to the ground. A design in which the QuadGuard CZ was anchored directly to the ground was accepted via Mr. Seppo Sillan's August 5, 1996 letter to your Mr. Roger Egan (acceptance letter CC35A). By mounting the crash cushion on a steel plate, it becomes easier to install, maintain, and eventually remove or relocate on an active construction site. The two-piece steel plate used in the test was 3/8-inch thick and was anchored through 6 inches of asphalt and approximately 8 inches of compacted base course using 30 3/4-inch diameter threaded steel rods (ASTM A193-B7) and a two-part polyester grout. The steel rods were 18-inches long. The tested design is shown in Enclosure 1.

To verify acceptable crash performance of the QuadGuard CZ mounted on steel plates, you ran National Cooperative Highway Research Program (NCHRP) Report 350 test 3-33, which members of my staff had previously agreed would likely place the greatest loading on the plate anchoring system. The crash cushion functioned as designed and the steel plate remained flat with no sign of lifting or bending. Since this test had been successfully run much earlier on a permanent QuadGuard, you did not instrument the truck used in the test so no occupant risk values were recorded or reported. Enclosure 2 is the test summary sheet. You had previously conducted test 3-38 into the side of QuadGuard CZ mounted on a 3/4-inch thick steel plate. In this test, the pickup truck was contained and redirected and, again, the steel plate showed no evidence of distress after the crash.

I agree that the QuadGuard CZ, in widths up to 36 inches, may be mounted on a steel plate with a minimum thickness of 3/8 inch, when anchored through asphalt as tested or when anchored as per your specifications through 6 inches (minimum) of concrete. Its NCHRP Report 350 test

level rating remains the same as for a permanent installation and is dependent on the number of bays used in a specific application.

Sincerely yours,

(original signed by John R. Baxter)

John R. Baxter, P.E.
Director, Office of Safety Design
Office of Safety

2 Enclosures

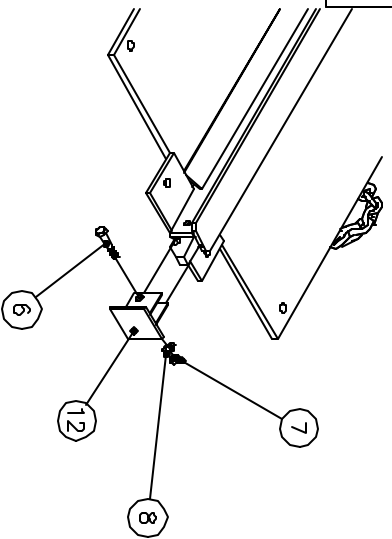

END PLATE ATTACHMENT

SCALE - 1:25
SEE NOTE 7

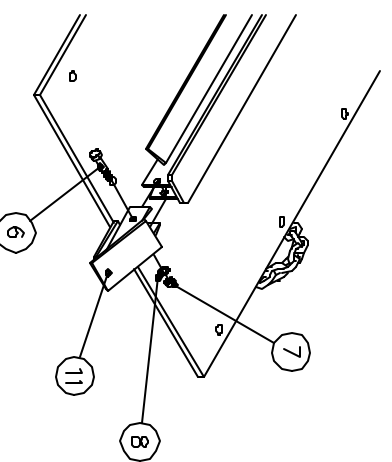

ENDCAP ATTACHMENT

SCALE - 1:25

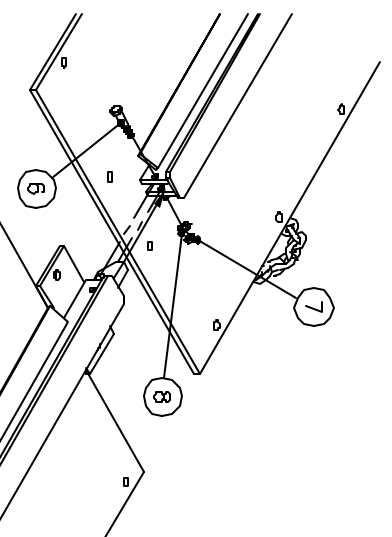

MONORAIL ATTACHMENT

SCALE - 1:25

PARTS LIST			
ITEM	STOCK NO.	DESCRIPTION	REQ'D
		BAYS →	
1	2700731-0500	ROD, THREADED, 3/4x18, G5, G	3 6 9
2	2704341-0000	NU T, HX, 3/4, G, GR DH	20 30 40
3	2708081-0000	WASHER, FLAT, 3/4x2, HVY, G	20 30 40
4	3525100-0000	MP - 3, QUART PACKAGE	5 8 10
6	2699571-0000	BOLT, HX, 5/8x3 1/2, G5, G	1 2 3
7	2704141-0000	NU T, HX, 5/8, G	1 2 3
8	2708231-0000	WASHER, LOCK, 5/8, G	1 2 3
9	35440237-0000	INST. OG PORTABLE CZ ANCHOR/LIFT KIT	1 1 1
10	2735492-0000	LABEL, CRATE, OG CZ LIFT KIT	1 1 1
11	2780040-0000	ENDCAP, MONORAIL, QPCCZ, G	1 1 1
12	2760042-0000	END PLATE, CZ LIFTING KIT	0 1 1

QUADGUARD CZ DECAL

NO. OF BAYS (DIAPHRAGMS)	ASSEMBLY NUMBER
3	35440233-0000
6	35440236-0000
9	35440239-0000

** TO MOVE SYSTEM AS A 9 BAY UNIT PLEASE CONTACT ENERGY ABSORPTION SYSTEMS CUSTOMER SERVICE DEPARTMENT.

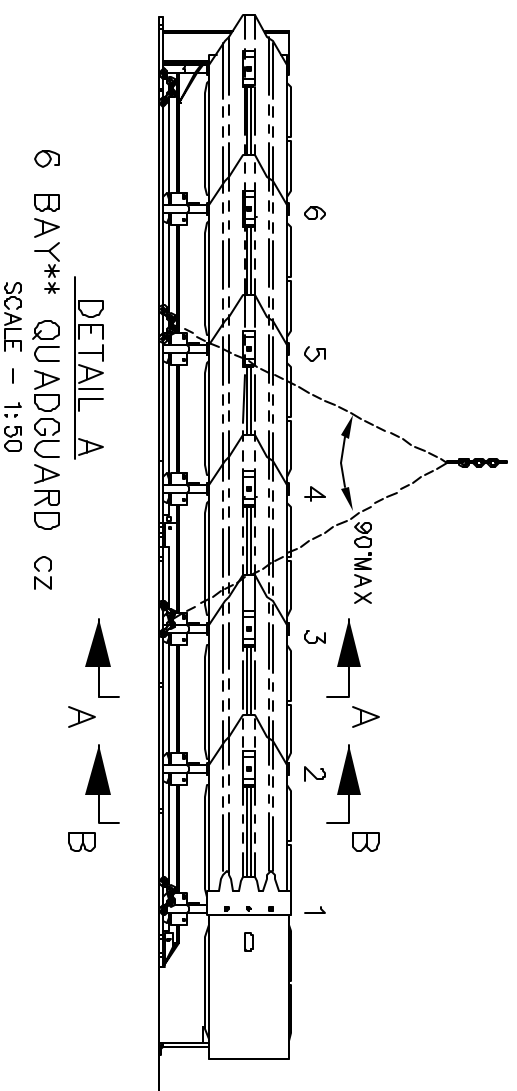

6 BAY** QUADGUARD CZ
SCALE - 1:50

ANCHOR SYSTEM:

1. CROSS SLOPE OF PLATE SHALL NOT EXCEED 8% AND NOT VARY MORE THAN 2% FROM FRONT TO BACK.
2. USE MP-3 POLYESTER ANCHOR SYSTEM, SUPPLIED BY ENERGY ABSORPTION SYSTEMS, OR APPROVED EQUAL QUADGUARD CZ SYSTEMS INSTALLED ON ASPHALT MUST BE INSPECTED TO ENSURE THE ANCHORS ARE STILL PROPERLY SET FOLLOWING EACH IMPACT. RE-ANCHOR AS NECESSARY.

TO MOVE SYSTEM IN 3 BAY SECTIONS:

1. REMOVE CARTRIDGE FROM BAYS THAT HAVE A MONORAIL BOLT CONNECTING SECTIONS TOGETHER BELOW THEM
2. REMOVE MUSHROOM BOLTS FOR THE BAY THAT HAS HAD THE CARTRIDGE REMOVED.
3. REMOVE ALL ANCHOR BOLTS.
4. REMOVE MONORAIL BOLTS THAT CONNECT SECTIONS TOGETHER.
5. LIFT ONLY ONE 3 BAY SECTION AT A TIME. START WITH NOSE SECTION FIRST.
6. PLACE SLING THROUGH THE LIFTING LOOPS ON EACH CORNER OF THE PLATE. THE SLING NEEDS TO BE A MINIMUM OF 9 FEET LONG OUT TO EACH LIFTING LOOP. MAKE SURE THAT THE SLING IS LONG ENOUGH THAT THE ANGLE IS LESS THAN 90° AS SHOWN.
7. FREE UNIT FROM ANCHOR BOLTS AND GROUT PRIOR TO LIFTING THE SYSTEM. TO ACCOMPLISH THIS, START AT THE NOSE OF THE SYSTEM AND USE PRY BARS TO GRADUALLY RAISE THE SYSTEM OFF OF THE STUDS. PLACE BLOCKS SUCH AS 2X4'S UNDER THE ANCHOR PLATES AND WORK DOWN THE LENGTH OF THE UNIT UNTIL THE UNIT IS COMPLETELY FREE OF THE STUDS.
8. INSTALL THE END PLATE (ITEM 12) OR ENDCAP (ITEM 11) ON EACH 3 BAY SECTION OF THE MONORAIL AS SHOWN (ITEM 12 NOT NEEDED FOR THE BACKUP SECTION). IF THE TOTAL UNIT HAS 7 OR MORE BAYS, BOTH THE ENDCAP AND END PLATE WILL NEED TO BE MOVED TO THE SECTION THAT IS BEING LIFTED TO PREVENT THE DIAPHRAGMS FROM SLIPPING OFF THE MONORAIL**.
9. LIFT THE SECTIONS TO NEW LOCATION, REMOVE END PLATE(S) AND RE-INSTALL SYSTEM (START WITH THE BACKUP).

TO MOVE AS A 6 BAY SYSTEM:

1. REMOVE ALL ANCHOR NUTS AND BOLTS.
2. PLACE SLING THROUGH THE FOUR LIFTING LOOPS IN THE CENTER OF THE 6 BAY SYSTEM. SEE DETAIL A.
3. FREE UNIT FROM ANCHOR BOLTS AND GROUT PRIOR TO LIFTING THE SYSTEM. TO ACCOMPLISH THIS, START AT THE NOSE OF THE SYSTEM AND USE PRY BARS TO GRADUALLY RAISE THE SYSTEM OFF OF THE STUDS. PLACE BLOCKS SUCH AS 2X4'S UNDER THE ANCHOR PLATES AND WORK DOWN THE LENGTH OF THE UNIT UNTIL THE UNIT IS COMPLETELY FREE OF THE STUDS.
4. LIFT THE SYSTEM TO NEW LOCATION AND RE-INSTALL.

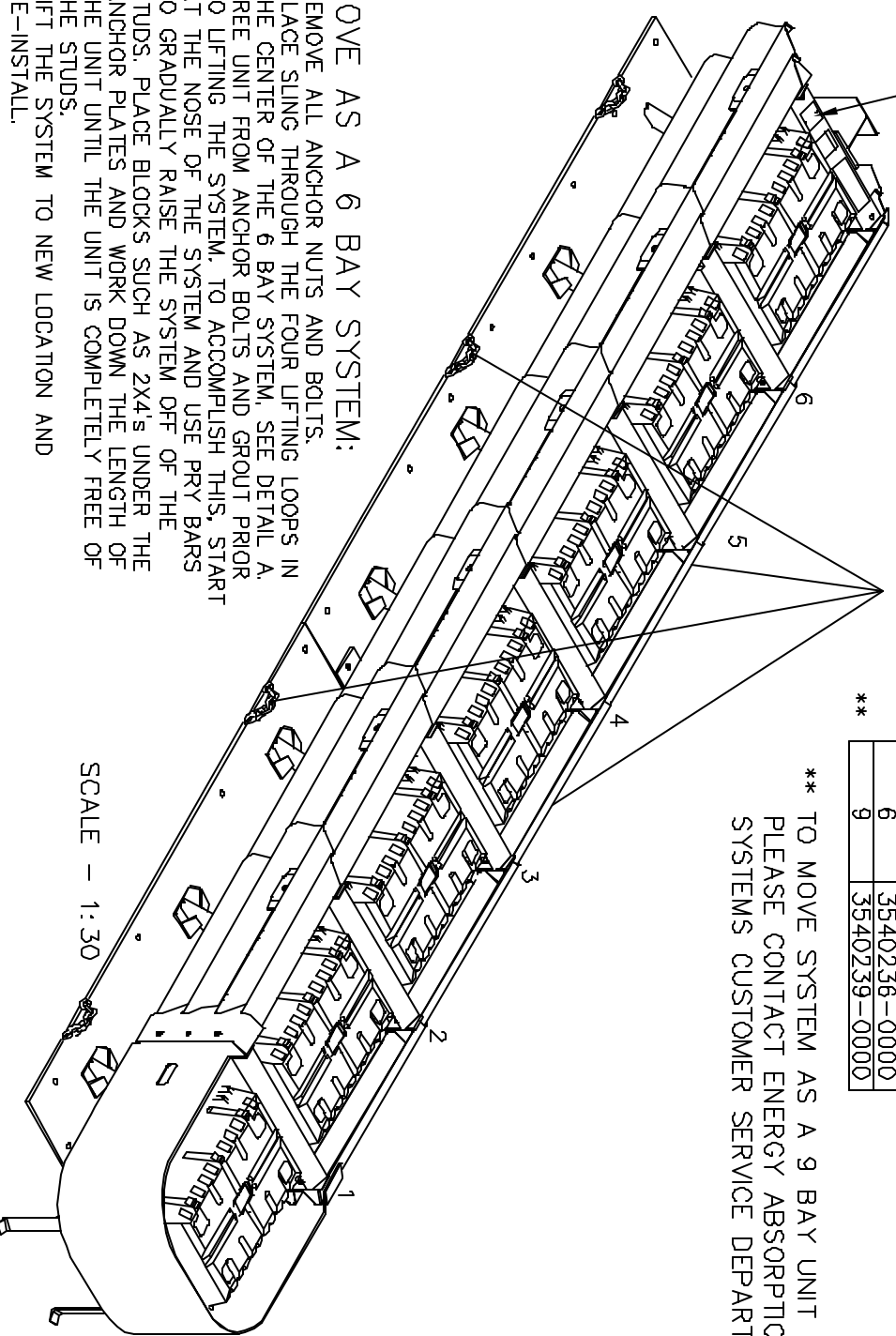

SCALE - 1:30

* SEE CHART

ASSEMBLY NO. 3524023*-0000

ENERGY ABSORPTION SYSTEMS, INC.
ENGINEERING AND RESEARCH DEPARTMENT

QuadGuard® SYSTEM

CZ, PORTABLE, ANCHOR/LIFTING KIT, OG,
3 BAY B/U, 3 BAY ADAPTER PLATES

Instruction No. 35440237-0000

Revisions	Date	Rev.	By	chkd.	App.	Q.C.
ITEM 11 WAS 2760041-0000, REM. 4, 5, 7 & 8 BAYS	05/09/03	A	LWC	BK	RCB	STI

DATE	DATE	DATE	DATE
03/21/03	03/28/03	03/28/03	03/28/03

NAME	DESIGNED	CHECKED	APPROVED	DATE
L. Corker	R. Brougher	K. Mortensen	R. Brougher	

DATE	DATE	DATE
03/21/03	03/28/03	03/28/03

SCALE	DATE	SHEET	REV
AS NOTED	35-40-23	1 of 3	A

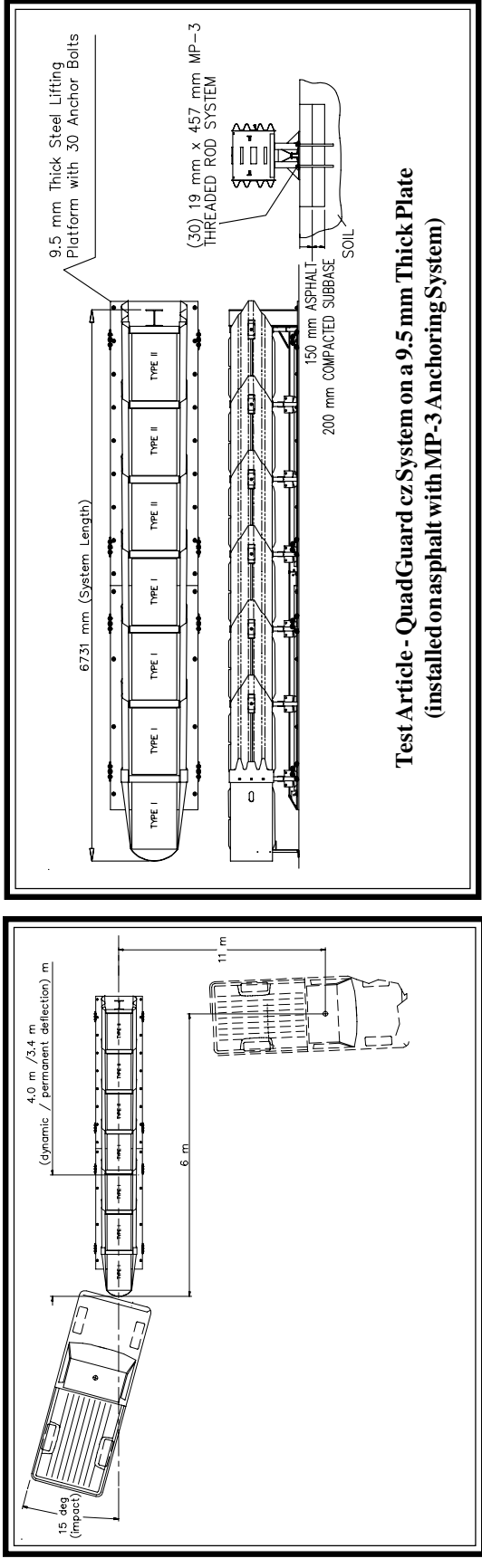

Test Article - QuadGuard cz System on a 9.5 mm Thick Plate
 (installed on asphalt with MP-3 Anchoring System)

General Information	
Test Agency	E-TECH Testing Services, Inc.
Test Designation	NCHRP 350 Test 3-33
Test No.	01-5500-006
Date	11/11/2003
Test Article	
Type	Energy Absorption Systems, Inc.
.....	QuadGuard cz System on a 9.5 mm Plate
.....	Model QZ2406P
Installation Length	6 bay 6.73 m (system length)
Material and key elements	(4) Type I cartridges
.....	(3) Type II cartridges
Foundation Type and Condition	150 mm thick asphalt over 200 mm
.....	aggregate base with (30) 19 mm x 457 mm
.....	ASTMA193 B7 threaded rods
.....	MP-3 Anchoring System
Test Vehicle	
Type	Production Model
Designation	2000P
Model	1988 Chevrolet
.....	C2500 Pickup
Mass (kg)	1898
Curb	2009
Test inertial	
Impact Conditions	
Speed (km/h)	101.8
Angle (deg)	15
Impact Severity (kJ)	802.6
Exit conditions	
Speed (km/h)	N/A
Angle (deg - veh. c.g.)	N/A
Occupant Risk Values	
.....	N/A *
European Committee for Normalization (CEN) Values	
.....	N/A *
Post-Impact Vehicular Behavior (deg - rate gyro)	
.....	N/A *
Test Article Deflections (m)	
Dynamic	4.0
Permanent	3.4

* Vehicle un-instrumented at request of client.

Figure 1. Summary of Results - QuadGuard cz System on a 9.5 mm Thick Plate Test 01-5500-006

The results of this report relate only to the QuadGuard QZ2406P configuration tested. This report may not be reproduced except in full, without the prior written approval of E-TECH Testing Services, Inc. Prepared by: John F. LaTurner, P.E. - Manager, Report 226 - Issued 11/03