



U.S. Department
of Transportation
**Federal Highway
Administration**

1200 New Jersey Ave., SE
Washington, D.C. 20590

Archived

In Reply Refer To:
HSST-1/B-40B

September 21, 2016

Mr. Gerrit Dyke, P.E.
Lindsay Transportation Solutions
180 River Road
Rio Vista, CA 94571

Dear Mr. Dyke:

This letter is in response to your December 23, 2015 request for the Federal Highway Administration (FHWA) to review a roadside safety device, hardware, or system for eligibility for reimbursement under the Federal-aid highway program. This FHWA letter of eligibility is assigned FHWA control number B-40B and is valid until a subsequent letter is issued by FHWA that expressly references this device.

Decision

The following devices are eligible, with details provided in the form which is attached as an integral part of this letter:

- Narrow QuickChange Moveable Barrier QMB modifications

Scope of this Letter

To be found eligible for Federal-aid funding, modified roadside safety devices should meet the crash test and evaluation criteria contained in the National Cooperative Highway Research Program (NCHRP) Report 350. However, the FHWA, the Department of Transportation, and the United States Government do not regulate the manufacture of roadside safety devices. Eligibility for reimbursement under the Federal-aid highway program does not establish approval, certification or endorsement of the device for any particular purpose or use.

This letter is not a determination by the FHWA, the Department of Transportation, or the United States Government that a vehicle crash involving the device will result in any particular outcome, nor is it a guarantee of the in-service performance of this device. Proper manufacturing, installation, and maintenance are required in order for this device to function as tested.

This finding of eligibility is limited to the crashworthiness of the system and does not cover other structural features, nor conformity with the Manual on Uniform Traffic Control Devices.

Only

Eligibility for Reimbursement

FHWA previously issued an eligibility letter for the roadside safety system described in your pending request. Your pending request now identifies a modification to that roadside safety system.

The original roadside safety device information is provided here:

Name of system:	Narrow QuickChange Moveable Barrier modifications
Type of system:	Portable / Moveable Longitudinal Barrier
Test Level	NCHRP Report 350 TL-3
Date of original request:	December 23, 2015
Original FHWA letter:	B-40 dated August 27, 1997
FHWA Control number:	B-40B

The pending modification(s) consists of the following changes:

- 1) Reduce diameter of bolt hole in base plate for rubber foot attachment
- 2) Stronger pin retaining clip
- 3) Modified spring pusher plate
- 4) More durable hydraulic breather cap

FHWA concurs with the recommendation of the accredited crash testing laboratory as stated within the attached form.

Full Description of the Eligible Device

The device and supporting documentation, including reports of the crash tests or other testing done, videos of any crash testing, and/or drawings of the device, are described in the attached form.

Notice

If a manufacturer makes any modification to any of their roadside safety hardware that has an existing eligibility letter from FHWA, the manufacturer must notify FHWA of such modification with a request for continued eligibility for reimbursement. The notice of all modifications to a device must be accompanied by:

- Significant modifications – For these modifications, crash test results must be submitted with accompanying documentation and videos.
- Non-signification modifications – For these modifications, a statement from the crash test laboratory on the potential effect of the modification on the ability of the device to meet the relevant crash test criteria.

FHWA's determination of continued eligibility for the modified hardware will be based on whether the modified hardware will continue to meet the relevant crash test criteria. You are expected to supply potential users with sufficient information on design, installation and maintenance requirements to ensure proper performance.

You are expected to certify to potential users that the hardware furnished has the same chemistry, mechanical properties, and geometry as that submitted for review, and that it will meet the test and evaluation criteria of the NCHRP Report 350.

Issuance of this letter does not convey property rights of any sort or any exclusive privilege. This letter is based on the premise that information and reports submitted by you are accurate and correct. We reserve the right to modify or revoke this letter if: (1) there are any inaccuracies in the information submitted in support of your request for this letter, (2) the qualification testing was flawed, (3) in-service performance or other information reveals safety problems, (4) the system is significantly different from the version that was crash tested, or (5) any other information indicates that the letter was issued in error or otherwise does not reflect full and complete information about the crashworthiness of the system.

Standard Provisions

- To prevent misunderstanding by others, this letter of eligibility designated as FHWA control number B-40B shall not be reproduced except in full. This letter and the test documentation upon which it is based are public information. All such letters and documentation may be reviewed upon request.
- This letter shall not be construed as authorization or consent by the FHWA to use, manufacture, or sell any patented system for which the applicant is not the patent holder.
- If the subject device is a patented product it may be considered to be proprietary. If proprietary systems are specified by a highway agency for use on Federal-aid projects: (a) they must be supplied through competitive bidding with equally suitable unpatented items; (b) the highway agency must certify that they are essential for synchronization with the existing highway facilities or that no equally suitable alternative exists; or (c) they must be used for research or for a distinctive type of construction on relatively short sections of road for experimental purposes. Our regulations concerning proprietary products are contained in Title 23, Code of Federal Regulations, Section 635.411.

Sincerely yours,



Michael S. Griffith
Director, Office of Safety Technologies
Office of Safety

Enclosures

Only

Request for Federal Aid Reimbursement Eligibility of Highway Safety Hardware

Submitter	Date of Request:	December 23, 2015	<input type="radio"/> New	<input checked="" type="radio"/> Resubmission
	Name:	Gerrit Dyke, P.E.		
	Company:	Lindsay Transportation Solutions		
	Address:	180 River Road, Rio Vista, CA, 94571		
	Country:	USA		
To:	Michael S. Griffith, Director FHWA, Office of Safety Technologies			

I request the following devices be considered eligible for reimbursement under the Federal-aid highway program.

Device & Testing Criterion - Enter from right to left starting with Test Level

!-!-

System Type	Submission Type	Device Name / Variant	Testing Criterion	Test Level
'B': Rigid/Semi-Rigid Barriers (Roadside, Median, Bridge Railings)	<input type="radio"/> Physical Crash Testing <input checked="" type="radio"/> Engineering Analysis	Narrow QMB	NCHRP Report 350	TL3

By submitting this request for review and evaluation by the Federal Highway Administration, I certify that the product(s) was (were) tested in conformity with the NCHRP Report 350 (Report 350) and that the evaluation results meet the appropriate evaluation criteria in the Report 350.

Individual or Organization responsible for the product:

Contact Name:	Gerrit Dyke, P.E.	Same as Submitter <input checked="" type="checkbox"/>
Company Name:	Lindsay Transportation Solutions	Same as Submitter <input checked="" type="checkbox"/>
Address:	180 River Road, Rio Vista, CA, 94571	Same as Submitter <input checked="" type="checkbox"/>
Country:	USA	Same as Submitter <input checked="" type="checkbox"/>

Enter below all disclosures of financial interests as required by the FHWA 'Federal-Aid Reimbursement Eligibility Process for Safety Hardware Devices' document.

Safe Technologies, Inc. (STI) performs testing and analysis services for Lindsay Transportation Solutions, Inc. (LTS). STI is a wholly owned subsidiary of LTS. STI is a fully accredited crash test facility by A2LA to ISO 17025 and recognized by the US Federal Highway Administration (FHWA) to perform full scale crash tests per NCHRP Report 350 and MASH criteria. STI also performs crash tests per the European EN1317 criteria in conjunction with an independent Notified Body. An Advisory Board includes third party industry experts and provides oversight and guidance to the laboratory management.

The STI laboratory manager, technicians, and laborers are compensated by LTS for salaries and wages. The STI staff does not receive any incentive, compensation, commissions, or professional fees corresponding to the outcome of any testing or analysis. The third party members of the Advisory Board are typically paid consultants. STI or staff does not receive any research funding or other research support from LTS. STI and staff also do not have any financial interest in patents, copyrights, or other intellectual property associated with the products they perform testing or analysis on.

Only

PRODUCT DESCRIPTION

- New Hardware or Significant Modification
 Modification to Existing Hardware

The Narrow QMB longitudinal barrier including the associated Variable Length Barriers (VLB), is a proprietary barrier that have been accepted for use on the National Highway System by FHWA under FHWA eligibility letter BB-40. This form describes four minor changes to the longitudinal barrier system:

- 1) Each Narrow QMB barrier element is equipped with 4 rubber feet that are attached to the barrier through clearance holes at the four corners of the base-plates. The holes are slightly larger than what is required for the 1/2" bolts connecting the feet. As a result, there is the potential for the bolts to work themselves loose over time due to excess wiggle room. This request is for the acceptance of a slight reduction to the diameter of the clearance holes in the base-plates. This modification represents no change to the function, capacity or performance of the barrier element or the longitudinal barrier system as a whole.
- 2) All Narrow QMB barrier elements are pinned together using a large 1-3/8" diameter pin. The pins have a small groove receiving a retaining clip that prevent the pins from working themselves out during the barrier transfer. Over the years a number of clips have fallen off. The failures are believed to be caused by fatigue. A stronger clip/washer configuration has been identified and proven to be up to 10 times more durable in bench testing. This request is for the acceptance of an alternative retaining clip. The clip does not come into play during crash testing, therefore this modification represents no change to the function, capacity or performance of the barrier element or the longitudinal barrier system as a whole.
- 3) There are two springs at each joint where the pins connect the Narrow QMB barrier elements. These springs apply pressure on the pins connecting the barriers such that any slop in the hinges is removed and the barriers are always in tension (this is how the barrier gets it's Reactive Tension designation). Having the barriers in tension helps reduce the deflection of the barrier wall during a crash. The springs sit in a mild steel housing and push against a "U" shaped plate that pushes against the pin. Over the years it was noticed that some springs have the potential of wearing a groove in the spring housing and occasionally get snagged in this groove such that they no longer apply pressure on the pin. A new "U" shaped plate was developed that has a small cylindrical rod welded to it's ends. This rod keeps the spring centered in the spring housing preventing it from wearing out the spring. This new "pusher plate" can be used on new barriers going forward as well as to retrofit old barriers that were damaged by a wondering spring. The pusher plate is centrally located between the barriers and does not come into play during crash testing, therefore this modification represents no change to the function, capacity or performance of the barrier element or the longitudinal barrier system as a whole.
- 4) A key components of these longitudinal barriers is the Variable Length Barrier (VLB). The proposed modification involves the replacement of a cap internal to the VLB. The VLB has a hydraulic cylinder that is connected to a hydraulic reservoir. This reservoir has a small breather cap. The original caps were made of black plastic (ABS) and weigh approximately 1.1 ounces. Occasionally these caps got damaged and sometimes went missing. The new cap is a more durable steel cap that weighs roughly 1.3 ounces. The weight difference is negligible considering the overall weigh of a VLB is 800lbs. Therefore, this modification represents no change to the function, capacity or performance of the barrier element or the longitudinal barrier system as a whole.

CRASH TESTING

By signature below, the Engineer affiliated with the testing laboratory, agrees in support of this submission that the Modification to Existing Hardware is deemed Non-significant for the device listed above to meet the MASH Report 350 Criteria.

Engineer Name:	Joseph Nagy	
Engineer Signature:	Joseph Nagy	Digitally signed by Joseph Nagy Date: 2016.08.29 11:15:39 -07'00'
Address:	170 River Road, Rio Vista, CA 94571	Same as Submitter <input type="checkbox"/>
Country:	USA	Same as Submitter <input type="checkbox"/>

A brief description of each crash test and its result:

Required Test Number	Narrative Description	Evaluation Results
3-10 (820C)	This test was originally run to support eligibility letter BB-40. The proposed modification represents no change to the function, capacity or performance of the SRTS/VLB system.	Modification has no effect on crashworthiness
S3-10 (700C)	Optional test, was not run. The proposed modification represents no change to the function, capacity or performance of the SRTS/VLB system.	Non-Relevant Test, not conducted
3-11 (2000P)	This test was originally run to support eligibility letter BB-40. The proposed modification represents no change to the function, capacity or performance of the SRTS/VLB system.	Modification has no effect on crashworthiness
3-20 (820C)	The CRTS/VLB has no transitions therefore this test was not required. The proposed modification represents no change to the function, capacity or performance of the SRTS/VLB system.	Non-Relevant Test, not conducted
S3-20 (700C)	Optional test, was not run. The proposed modification represents no change to the function, capacity or performance of the SRTS/VLB system.	Non-Relevant Test, not conducted
3-21 (2000P)	The CRTS/VLB has no transitions therefore this test was not required. The proposed modification represents no change to the function, capacity or performance of the SRTS/VLB system.	Non-Relevant Test, not conducted

Testing Laboratory's signature concurs that these modifications are considered Non-significant.		
Laboratory Name:	Safe Technologies, Inc.	
Laboratory Signature:	Joseph Nagy	Digitally signed by Joseph Nagy Date: 2016.08.29 11:17:35 -07'00'
Address:	170 River Road, Rio Vista, CA 94571	Same as Submitter <input type="checkbox"/>
Country:	USA	Same as Submitter <input type="checkbox"/>
Accreditation Certificate Number and Dates of current Accreditation period :	1851.01, Valid through March 31, 2017	

Submitter Signature*: **Gerrit Dyke** Digitally signed by Gerrit Dyke
Date: 2016.08.29 11:18:04 -07'00'

Submit Form

Only

ATTACHMENTS

Attach to this form:

- 1) Additional disclosures of related financial interest as indicated above.
- 2) A copy of the full test report, video, and a Test Data Summary Sheet for each test conducted in support of this request.
- 3) A drawing or drawings of the device(s) that conform to the Task Force-13 Drawing Specifications [[Hardware Guide Drawing Standards](#)]. For proprietary products, a single isometric line drawing is usually acceptable to illustrate the product, with detailed specifications, intended use, and contact information provided on the reverse. Additional drawings (not in TF-13 format) showing details that are relevant to understanding the dimensions and performance of the device should also be submitted to facilitate our review.

FHWA Official Business Only:

Eligibility Letter		
Number	Date	Key Words

The Narrow QMB longitudinal barrier including the associated Variable Length Barriers (VLB), is a proprietary barrier that have been accepted for use on the National Highway System by FHWA under FHWA eligibility letter BB-40. This form describes four minor changes to the longitudinal barrier system:

1) Each Narrow QMB barrier element is equipped with 4 rubber feet that are attached to the barrier through clearance holes at the four corners of the base-plates. The holes are slightly larger than what is required for the 1/2" bolts connecting the feet. As a result, there is the potential for the bolts to work themselves loose over time due to excess wiggle room. This request is for the acceptance of a slight reduction to the diameter of the clearance holes in the base-plates. This modification represents no change to the function, capacity or performance of the barrier element or the longitudinal barrier system as a whole.



Oversized hole

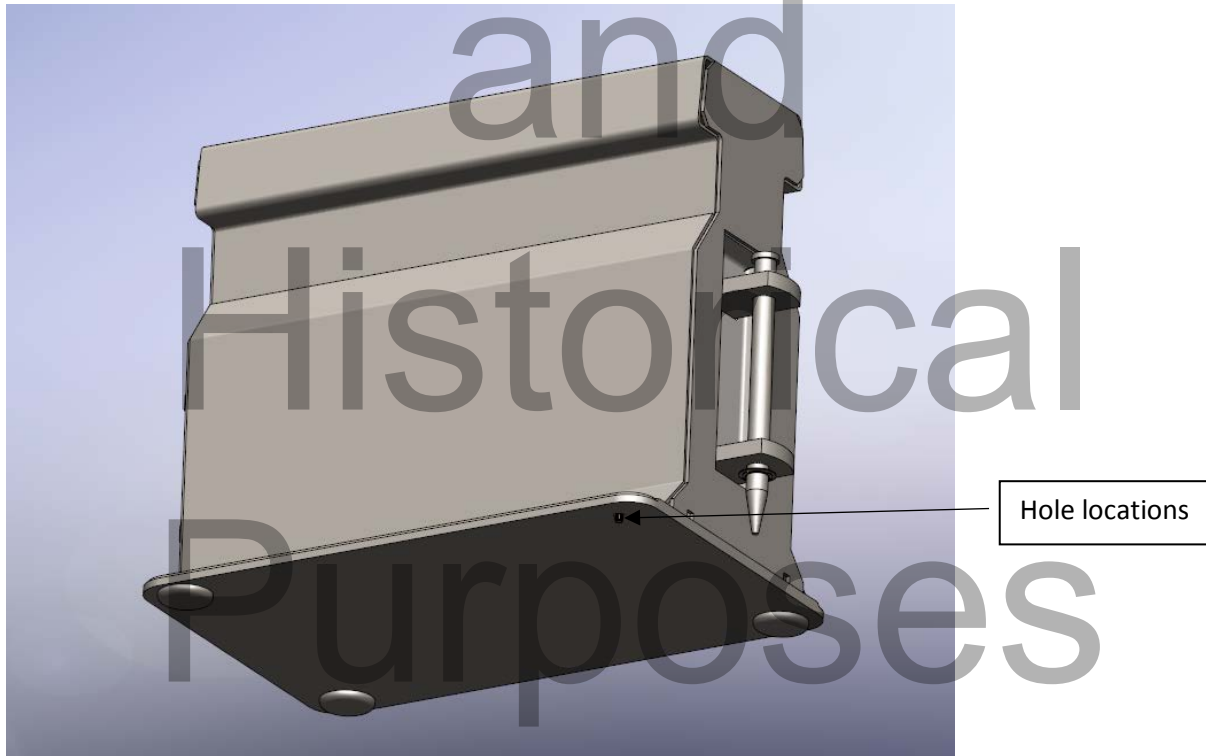

Only

2) All Narrow QMB barrier elements are pinned together using a large 1-3/8" diameter pin. The pins have a small groove receiving a retaining clip that prevent the pins from working themselves out during the barrier transfer. Over the years a number of clips have fallen off. The failures are believed to be caused by fatigue. A stronger clip/washer configuration has been identified and proven to be up to 10 times more durable in bench testing. This request is for the acceptance of an alternative retaining clip. The clip does not come into play during crash testing, therefore this modification represents no change to the function, capacity or performance of the barrier element or the longitudinal barrier system as a whole.



New clip is shown on the left and the old clip on the right.

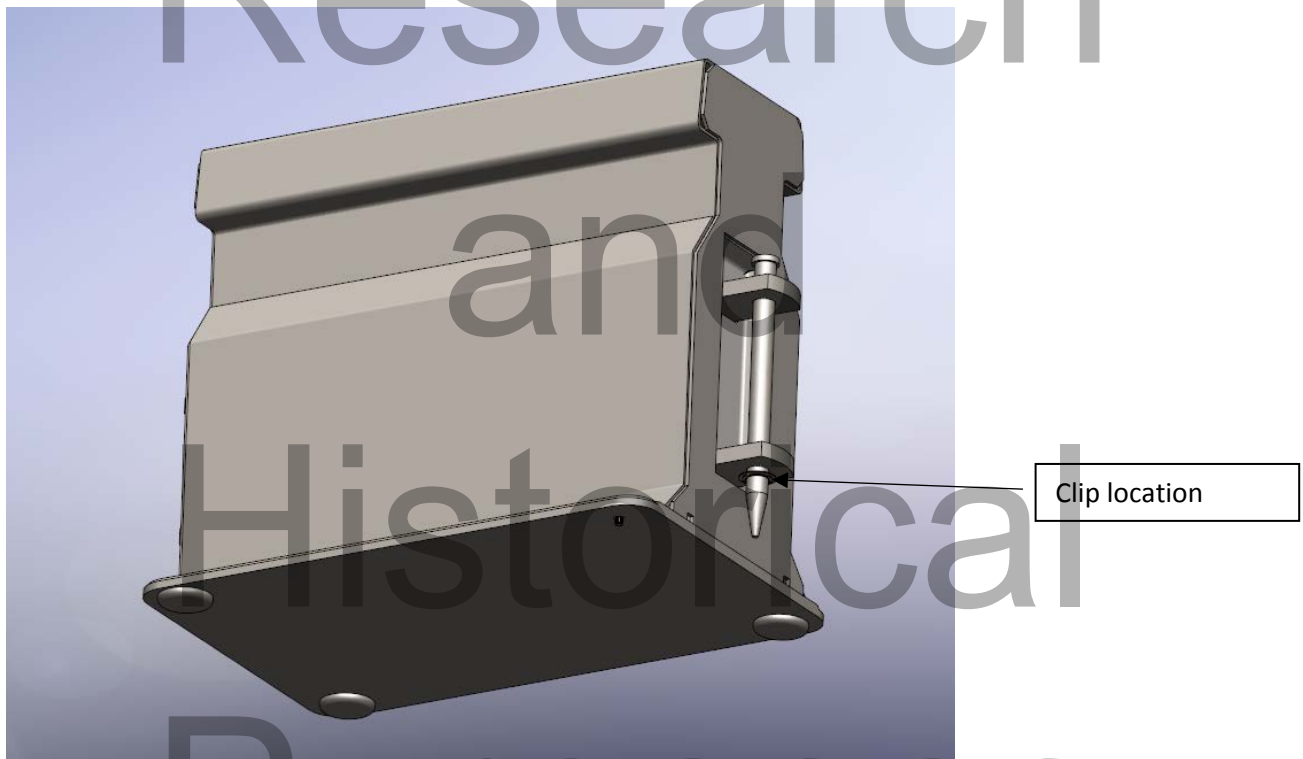

Clip location

Only

3) There are two springs at each joint where the pins connect the Narrow QMB barrier elements. These springs apply pressure on the pins connecting the barriers such that any slop in the hinges is removed and the barriers are always in tension (this is how the barrier gets its Reactive Tension designation). Having the barriers in tension helps reduce the deflection of the barrier wall during a crash. The springs sit in a mild steel housing and push against a "U" shaped plate that pushes against the pin. Over the years it was noticed that some springs have the potential of wearing a groove in the spring housing and occasionally get snagged in this groove such that they no longer apply pressure on the pin. A new "U" shaped plate was developed that has a small cylindrical rod welded to its ends. This rod keeps the spring centered in the spring housing preventing it from wearing out the spring. This new "pusher plate" can be used on new barriers going forward as well as to retrofit old barriers that were damaged by a wondering spring. The pusher plate is centrally located between the barriers and does not come into play during crash testing, therefore this modification represents no change to the function, capacity or performance of the barrier element or the longitudinal barrier system as a whole.

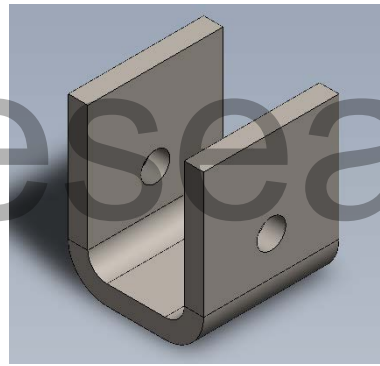
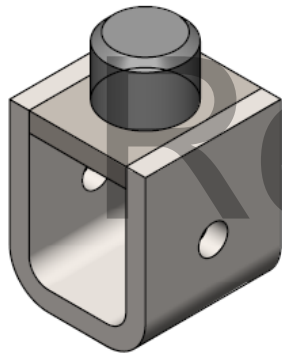

New Pusher Plate on the left

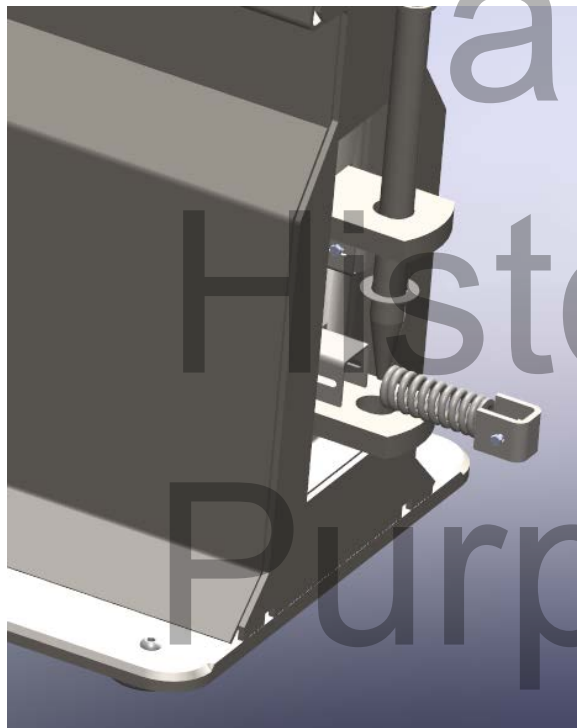

Pusher Plate

Only

4) A key components of these longitudinal barriers is the Variable Length Barrier (VLB). The proposed modification involves the replacement of a cap internal to the VLB. The VLB has a hydraulic cylinder that is connected to a hydraulic reservoir. This reservoir has a small breather cap. The original caps were made of black plastic (ABS) and weigh approximately 1.1 ounces. Occasionally these caps got damaged and sometimes went missing. The new cap is a more durable steel cap that weighs roughly 1.3 ounces. The weight difference is negligible considering the overall weigh of a VLB is 800lbs. Therefore, this modification represents no change to the function, capacity or performance of the barrier element or the longitudinal barrier system as a whole.



Old cap on the left.

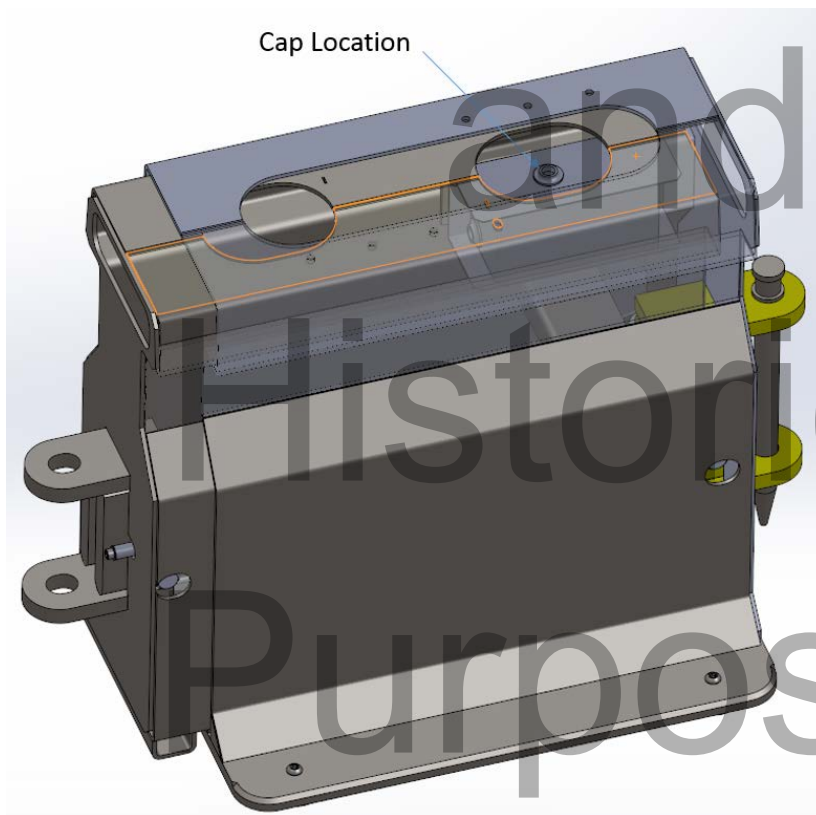

Only