



U.S. Department  
of Transportation

**Federal Highway  
Administration**

400 Seventh St., S.W.  
Washington, D.C. 20590

JUN 27 2000

Refer to: HSA-B69

Mr. Edwin M. Wood  
Vice President  
Barrier Systems, Inc.  
1100 E. William Street, Suite 206  
Carson City, NV 89701

Dear Mr. Wood:

In your May 16 letter you requested the Federal Highway Administration's (FHWA) acceptance of two types of moveable barriers, a Steel Reactive Tension System (SRTS) and a Concrete Reactive Tension System (CRTS), for use on the National Highway System (NHS) at National Cooperative Highway Research Program Report 350 Test Level 3 (TL-3). To support this request, you sent copies of an April 2000 report entitled "NCHRP Report 350 Crash Test Results - Reactive Tension System (RTS) Quickchange Moveable Barrier (QMB) (Longitudinal Barrier)," prepared by Safe Technologies, Inc., plus videotapes and CDs showing the tests that were conducted.

The Steel Reactive Tension System is identical to the Narrow Quickchange Moveable barrier previously accepted by the FHWA (Acceptance Letter B-40, dated 8/27/97), except that the SRTS modules use spring-loaded hinges which keep the individual segments in tension and the Variable Length Barrier (VLB) used in the system has been redesigned. The new design of the standard module is shown as Enclosure 1.

The Concrete Reactive Tension System is similar to the original Quickchange Moveable Barrier which was formally accepted by FHWA by Acceptance Letter B-63 on January 5, 2000, but it also uses spring-loaded hinges to minimize deflection and its vertical sides make it narrower than the original QMB design by 150 mm (6 inches), making its total width 460 mm (18 inches). This design is shown in Enclosure 2.

Enclosure 3 consists of summary sheets of the three tests you ran on the CRTS and of the single test you ran on the SRTS. When the two systems were tethered to a ground anchor capable of supporting a 100,000-pound barrier load, we noted that vehicle containment and redirection was very good in all tests and that the maximum deflection was only 700 mm for the SRTS and 610 mm for the CRTS.

Based on instrumented measurements taken during one of your certification tests, you stated in your letter that this same minimal deflection could be expected if, in lieu of an anchor at each end of the installation, an additional 80 CRTS or SRTS elements were placed upstream (and presumably downstream) from the point at which these small deflection distances were required.

Based on the tests conducted and the information you provided, I agree that the CRTS and the SRTS QMB designs meet the evaluation criteria for a TL-3 longitudinal barrier and they may be used on the NHS when such use is requested by a transportation agency. Since both systems are proprietary, their use on Federal-aid projects, except exempt, non-NHS projects, remains subject to the conditions listed in Title 23, Code of Federal Regulations, Section 635.411.

Sincerely yours,

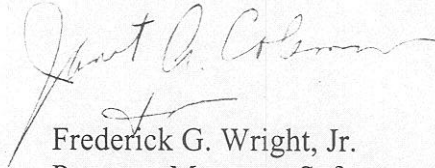
A handwritten signature in cursive script, appearing to read "Frederick G. Wright, Jr.", written in dark ink.

Frederick G. Wright, Jr.  
Program Manager, Safety

3 Enclosures

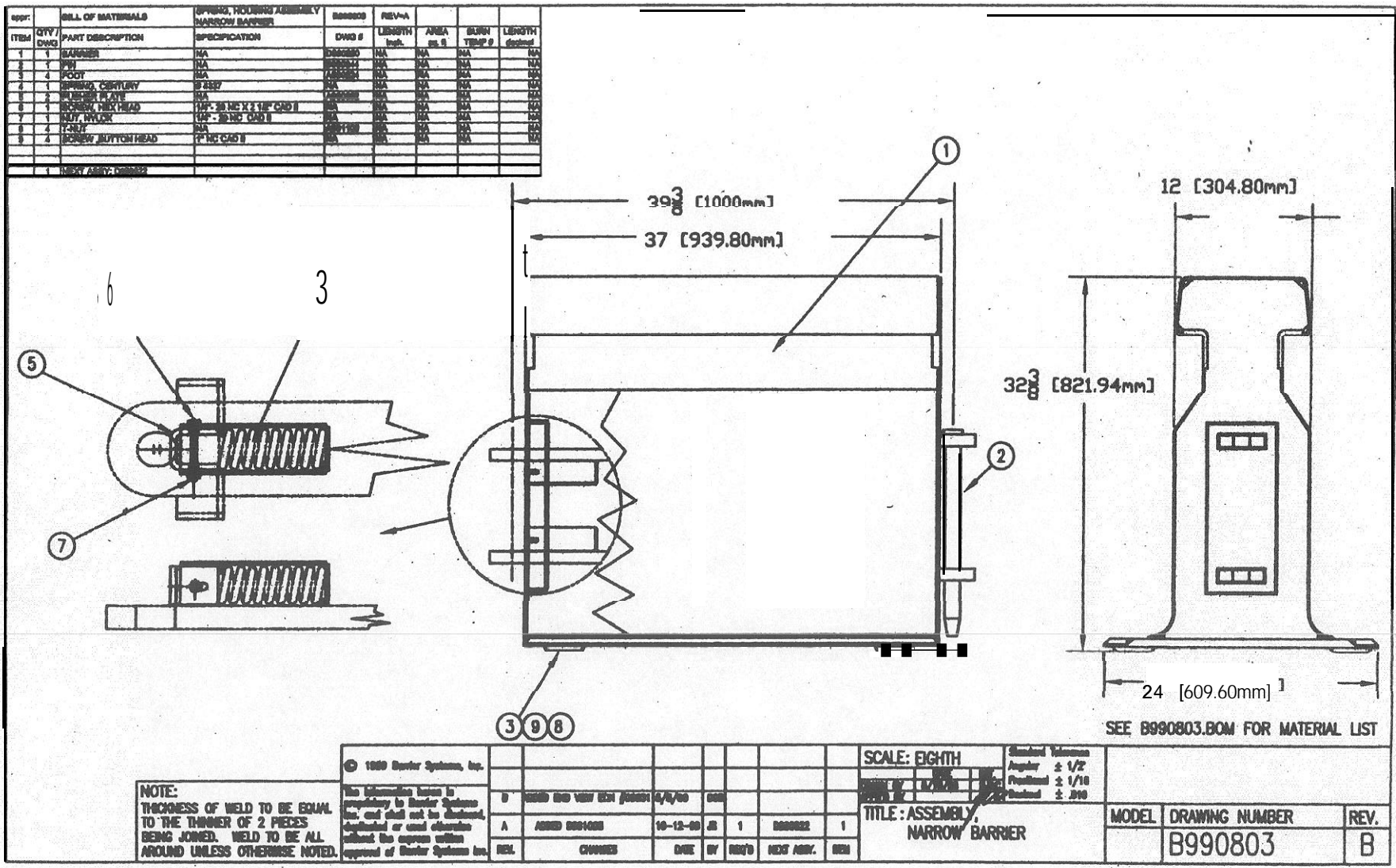

appr:		BILL OF MATERIALS		18" CONCRETE BARRIER REACTIVE TENSION SYSTEM		C000205		
ITEM	QTY / DWG	PART DESCRIPTION	SPECIFICATION	DWG #	LENGTH Inch.	AREA sq. ft.	BURN TEMP #	LENGTH decimal
1	1	18" REACTIVE TENSION SYSTEM CONCRETE BARRIER	NA	D091010	NA	NA	NA	NA
2	1	PIN	NA	B990844	NA	NA	NA	NA
3	2	FOOT BUMBER RH CONCRETE BARRIER	NA	C000205	NA	NA	NA	NA
4	2	FOOT BUMBER LH CONCRETE BARRIER	NA	C000207	NA	NA	NA	NA
5	2	PUSHER PLATE	NA	A990802	NA	NA	NA	NA
6	2	SPRING, CENTURY	# 4337	NA	NA	NA	NA	NA
7	2	NUT, NYLOK	1/4 20 NC PLTD	NA	NA	NA	NA	NA
8	2	SCREW HEX HD CAP	1/4 20 NC x 2 1/2 LG CAD	NA	NA	NA	NA	NA
9	4	WASHER, FLAT	3/8 DIA CAD	NA	NA	NA	NA	NA
10	4	NUT, LOCK SPECIAL DIMPLED, LORD AND SON	3/8 18 NC HOT DIPPED GALVANIZED	NA	NA	NA	NA	NA
11	1	E-RING TRIANG	#X3133-118 CAD PLATED	NA	NA	NA	NA	NA

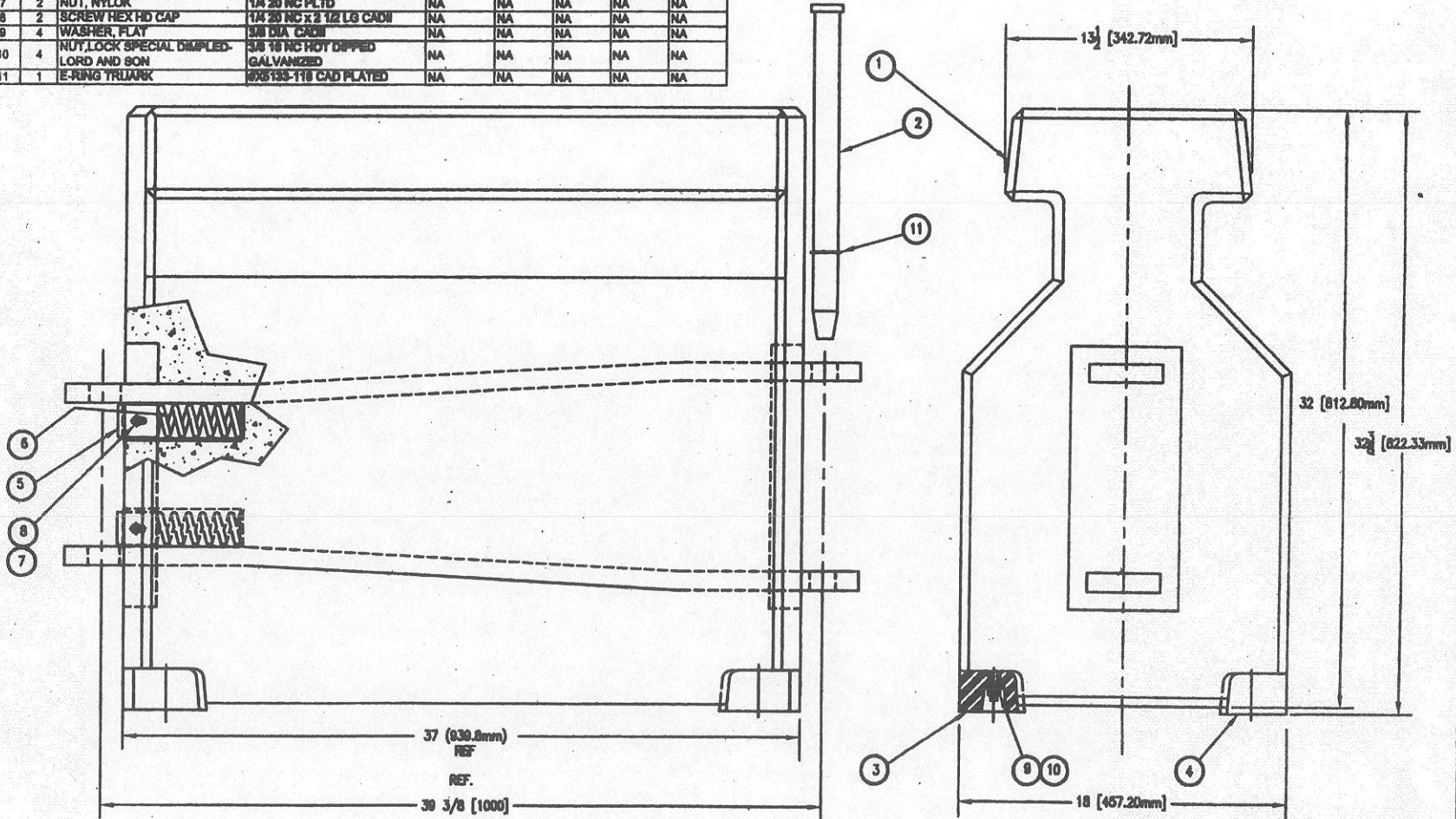

NOTE: REWORKING OF WELD TO BE HELD TO THE TOLERANCE OF 2 POINTS FROM JOINT. WELD TO BE ALL

DATE	BY	CHKD	APP'D	SCALE: QUARTER	Angular ± 1/2° Parallel ± 1/32" Vertical ± .005"
				TITLE: 18" CONCRETE BARRIER REACTIVE TENSION SYSTEM	MODEL: C000205
					DRAWING NUMBER: C000205
					REV.

Figure D-1  
RTS-QMB Test Results





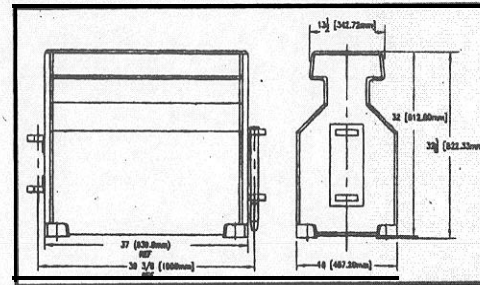
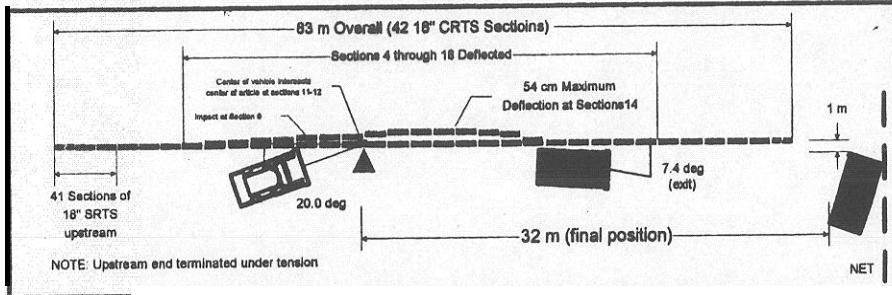
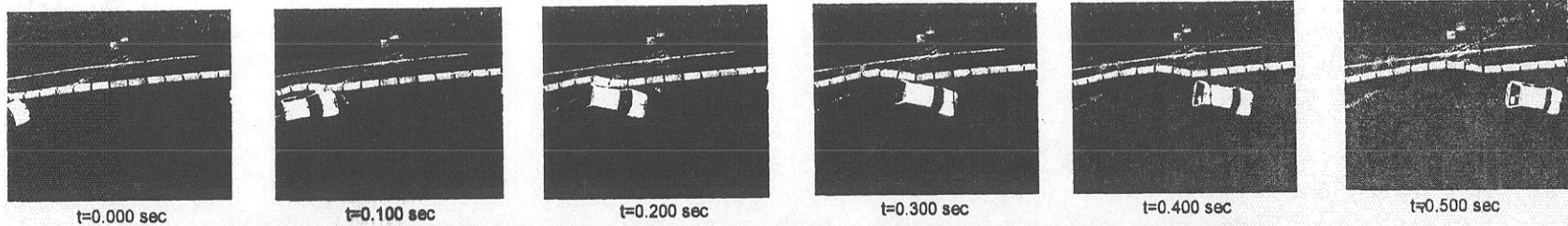

#### General Information

Test Agency..... SAFE TECHNOLOGIES, INC.  
 Test Designation..... NCHRP 350 3-10  
 Test No..... RTS02  
 Date..... 4/19/00

#### Test Article

Type..... Barrier Systems Inc.  
 18 CRTS-QMB Longitudinal Barrier

Installation Length ..... 42 meters (83 meters overall)

Size and/or dimension an<sup>2</sup> material  
 of key elements ..... Section length 1000mm, Height 822mm,  
 width 457mm, mass 700kg

#### Test Vehicle

Type..... Production Model  
 Designation ..... 820C  
 Model ..... 1990, Ford Festiva

Mass (kg)  
 Curb..... 795  
 Test Inertial ..... 837  
 Dummy(s)..... 7.5  
 Gross Static..... 912

#### Impact Conditions

Speed (km/h)..... 1047  
 Angle (deg)..... 20  
 Impact Severity (kj)..... 41.4

#### Exit Conditions

Speed (km/h) ..... 70  
 Angle (deg) ..... 7.4

#### occupant risk Values

Impact Velocity(m/s)  
 x-direction ..... 4.5  
 y-direction..... .7  
 Ridedown Acceleration (g's)  
 x-direction ..... 8.3  
 y-direction ..... 18.2  
 THIV (m/s)... 8.6  
 PHD (g's) ..... 19.9  
 AS ..... 1.39

#### Vehicle Damage

Exterior  
 VDS..... LFQ-3  
 CDC..... 11FLEE2  
 Interior  
 OCDI..... AS0000000

#### Post-Impact Vehicular behavior (deg - gyro @ c.g.)

Maximum Roll Angle..... -16.1 (-14 deg at exit)  
 Maximum Pitch Angle..... -8.1 (-6 deg at exit)  
 Maximum Yaw Angle..... -68.4 (28 deg at exit)

Figure 6. Summary of Results CRTS Test #RTS02

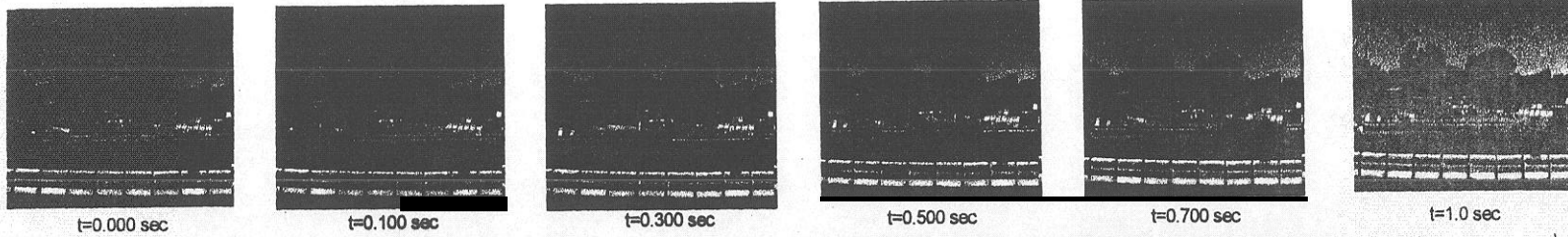

NOTE: Overhead high speed video for RTS03 was lost due to technical difficulties

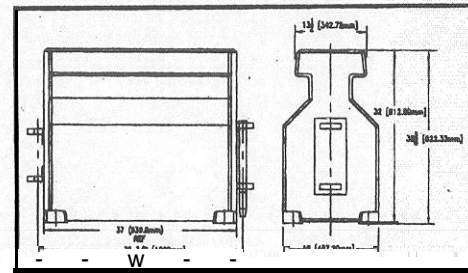
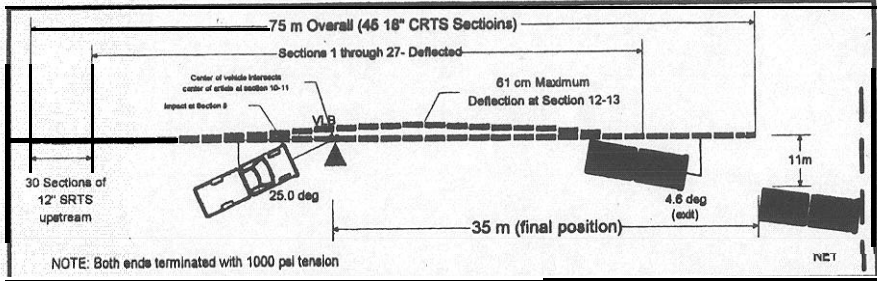

**General Information**

Test Agency..... **SAFE TECHNOLOGIES, INC.**  
 Test Designation..... **NCHRP 350 3-11**  
 Test No..... **RTS03**  
 Date..... **4/28/00**

**Test Article**

Type ..... **Barrier Systems, CRTS Longitudinal Barrier**  
 Installation Length ..... **45 meters (75 meters overall)**  
 Size and/or dimension and material of key elements ..... **Section length 1000mm, height 822mm, width 457mm, mass 700kg**

**Test Vehicle**

Type... .. **Production Model**  
 Designation... .. **2000P**  
 Model..... **1990 Chevrolet P i -**

**Mass (kg)**

Curb..... **189€**  
 Test Inertial..... **199€**  
 Dummy(s)..... **n/a**  
 Gross Static..... **199€**

**Impact Conditions**

Speed (km/h) ..... **98.9**  
 Angle (deg). ..... **25**  
 Impact Severity (kj). ..... **135**

**Exit Conditions**

Speed (km/h)..... **66.3**  
 Angle (deg)..... **7.1**

**Occupant risk Values**

Impact Velocity (m/s)  
 x-direction..... **5.9**  
 y-direction..... **-6.8**  
 Ridedown Acceleration (g's)  
 x-direction..... **-7.1**  
 y-direction..... **13.9**  
 THIV (m/s)..... **8.6**  
 PHD (g's)..... **31.1**  
 ASI..... **1.3**

**Vehicle Damage**

**Exterior**  
 VDS.. - - - **F14**  
 CDC..... **11FLEE3**  
**Interior**  
 OCD ..... **AS000000**  
**Roll-over** Vehicular behavior (deg gym @ c.g)  
 Maximum Roll Angle ..... **-13.8 (at exit)**  
 Maximum Pitch Angle ..... **-2.9 (at exit)**  
 Maximum Yaw Angle ..... **40 (28 deg at exit)**

**Figure 11. Summary of Results CRTS Test #RTS03**



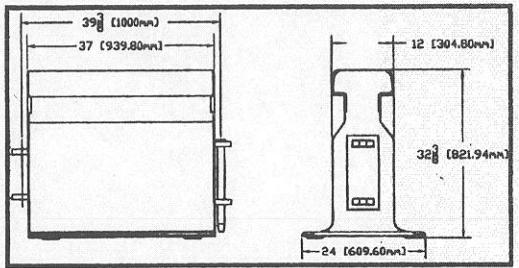
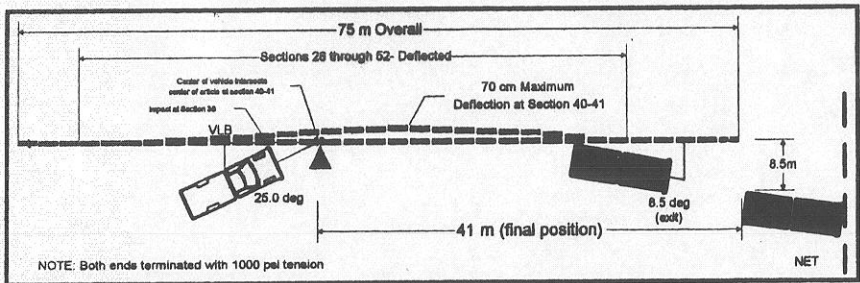
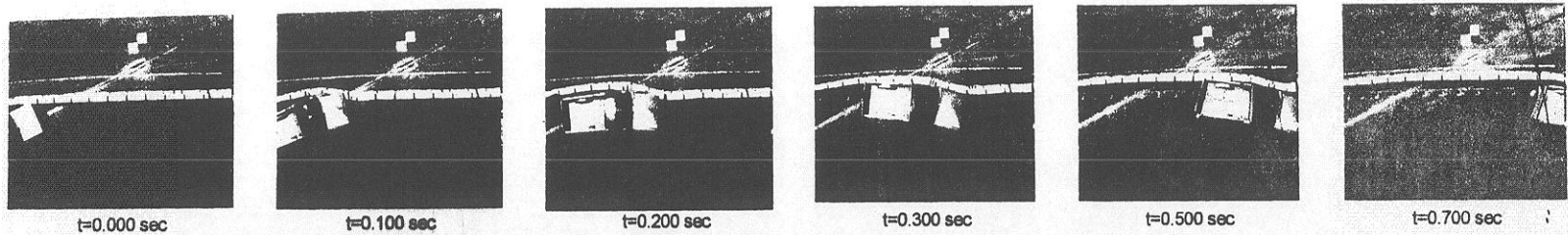

**General Information**

Test Agency.....	SAFE TECHNOLOGIES, INC.
Test Designation.....	NCHRP 350 3-11
Test No.....	RTS04
Date.....	5/3/00

**Test Article**

Type.....	Barrier Systems, Inc. SRTS Longitudinal Barrier
Installation Length.....	75 meters overall
Size and/or dimension and material of key elements.....	Section length 1000mm, height 822mm, width 305mm (at base 610mm), mass 686kg

**Test Vehicle**

Type.....	Production Model
Designation.....	2000P
Model.....	1988, Chevrolet 3/4 Ton Pickup

Mass (kg)	
Curb.....	2035
Test Inertial.....	1997
Dummy(s).....	n/a
Gross Static.....	1997

**Impact Conditions**

Speed (km/h).....	99.2
Angle (deg).....	25
Impact Severity (kJ).....	135

**Exit Conditions**

Speed (km/h).....	68
Angle (deg).....	8.5

**Occupant risk Values**

Impact Velocity (m/s)	
x-direction.....	5.1
y-direction.....	-7.2
Ridedown Acceleration (g's)	
x-direction.....	-11.6
y-direction.....	10
THIV (m/s).....	7.9
PHD (g's).....	16.7
ASI.....	1.22

**Vehicle Damage**

Exterior	
VDS.....	FLQ-4
CDC.....	11FLEE3
Interior	
OCDI.....	AS0000000

**Post-Impact Vehicular behavior (deg - gyro @ c.g.)**

Maximum Roll Angle.....	11.4 (6 deg at exit)
Maximum Pitch Angle.....	4.2 (-4 deg at exit)
Maximum Yaw Angle.....	47.7 (36 deg at exit)

Figure 16. Summary of Results SRTS Test #RTS04