

## Errata

Date: May 20, 2025  
 Issuing Office: Federal Highway Administration—Office of Research, Development, and Technology: Infrastructure R&D  
 Address: Turner-Fairbank Highway Research Center, 6300 Georgetown Pike, McLean, VA 22101

Name of Document: **Using Falling Weight Deflectometer Data With Mechanistic-Empirical Design and Analysis, Volume III: Guidelines for Deflection Testing, Analysis, and Interpretation**

FHWA Publication No.: **FHWA-HRT-16-011**

The following changes were made to the document after publication on the Federal Highway Administration website:

Location	Incorrect Values	Corrected Values
Foreword page, in the notice box	The U.S. Government does not endorse products or manufacturers. Trademarks or manufacturers' names appear in this report only because they are considered essential to the objective of the document.	<b>Non-Binding Contents</b>  Except for the statutes and regulations cited, the contents of this document do not have the force and effect of law and are not meant to bind the States or the public in any way. This document is intended only to provide information regarding existing requirements under the law or agency policies.
Page 80, item #1; in "HMA Materials" (page 79) section	$E_{dam}$	$E_{FWD}$
Page 80, item #4, first line; in "HMA Materials" (page 79) section	Estimate the damage by solving for the fatigue damage in the HMA layer, $d_{ac}$ , in the equation in figure 52.	Estimate the fatigue damage in the existing HMA layer, $d_{ac}$ , using the equation in figure 52. Note that the value of $E^*$ to be used in this equation should be selected from the undamaged master curve obtained in step 3 at a reduced frequency (or time) that represents FWD test temperature and frequency.
Page 80, item #4, equation in in figure 52; in "HMA Materials" (page 79) section	$E^*_{dam} = 10^\delta + \frac{E^* - 10^\delta}{1 + e^{-0.3+5 \times \log(d_{ac})}}$	$\log(d_{ac}) = 0.2 \left[ \ln \left( \frac{E^* - E_{FWD}}{E_{FWD} - 10^\delta} \right) + 0.3 \right]$
Page 80, item #4, figure 52 caption; in "HMA Materials" (page 79) section	Figure 52. Equation. Estimate of damaged modulus.	Figure 52. Equation. Estimate of damage ( $d_{ac}$ ).

Location	Incorrect Values	Corrected Values
Page 80, item #4; in “HMA Materials” (page 79) section	$E^*_{dam}$ = Damaged modulus, lbf/in <sup>2</sup> from step 1.	$E_{FWD}$ = backcalculated HMA modulus from FWD testing, lbf/in <sup>2</sup> from step 1.
Page 81, item #5; in “HMA Materials” (page 79) section	Determine $\alpha'$ as shown in figure 53.	Keeping $d_{ac}$ at the constant value as estimated from step 4, determine the damaged modulus master curve, $E^*_{dam}$ of the existing damaged HMA layer from the equation shown in figure 53.
Page 81, item #5, equation in figure 53; in “HMA Materials” (page 79) section	$\alpha' = (1 - d_{ac})\alpha$	$E^*_{dam} = 10^\delta + \frac{E^* - 10^\delta}{1 + e^{-0.3+5 \times \log(d_{ac})}}$
Page 81, item #5, figure 53 caption; in “HMA Materials” (page 79) section	Figure 53. Equation. Determination of $\alpha'$ .	Figure 53. Equation. Determination of damaged modulus.
Page 81, item #5, paragraph after figure caption; in “HMA Materials” (page 79) section	N/A	Where:  $E^*_{dam}$ = Damaged modulus, lbf/in <sup>2</sup> .
Page 81, item #6, first line of paragraph; in “HMA Materials” (page 79) section	Determine the field master curve using $\alpha'$ in the equation in figure 51 instead of $\alpha$ .	N/A (delete this line)
Table 36, page 97, row 2, column 3 (excluding header row), bulleted list first bullet	• Backcalculate existing (damaged) layer moduli ( $E_{dam}$ ) from deflection testing.	• Backcalculate existing (damaged) layer moduli ( $E_{FWD}$ ) from deflection testing.
Table 36, page 97, row 2, column 3 (excluding header row), bulleted list fourth bullet	• Determine $\alpha'$ .	Determine the modulus master curve using $d_{ac}$ .

---

# Using Falling Weight Deflectometer Data with Mechanistic-Empirical Design and Analysis, Volume III: Guidelines for Deflection Testing, Analysis, and Interpretation

---

PUBLICATION NO. FHWA-HRT-16-011

DECEMBER 2017



U.S. Department of Transportation  
**Federal Highway Administration**

Research, Development, and Technology  
Turner-Fairbank Highway Research Center  
6300 Georgetown Pike  
McLean, VA 22101-2296

## FOREWORD

This report documents a study conducted to investigate the use of the falling weight deflectometer (FWD) as part of mechanistic-empirical pavement design and rehabilitation procedures incorporated within the *Mechanistic-Empirical Pavement Design Guide* (MEPDG) developed by the National Cooperative Highway Research Program and subsequently adopted by the American Association of State Highway and Transportation Officials. The first volume of this three-volume report, documents general pavement deflection-testing procedures and commonly used deflection analysis approaches and a review of backcalculation programs for flexible, rigid, and composite pavement structures. The relevance of the different procedures and approaches to the MEPDG were explored through examination of six case studies evaluated using FWD testing results in the MEPDG, and the findings are presented in the second volume. Based on the case study findings and information from the literature, best practice guidelines for effective testing of existing pavement structures and interpretation of those results as part of a mechanistic-empirical pavement evaluation and rehabilitation process were developed and are presented here in the third volume. This report is intended for use by pavement engineers as well as researchers involved in rehabilitation design and management of agencies' pavements.

Cheryl Allen Richter, P.E., Ph.D.  
Director, Office of Infrastructure  
Research and Development

### Notice

This document is disseminated under the sponsorship of the U.S. Department of Transportation (USDOT) in the interest of information exchange. The U.S. Government assumes no liability for the use of the information contained in this document.

The U.S. Government does not endorse products or manufacturers. Trademarks or manufacturers' names appear in this report only because they are considered essential to the objective of the document.

### Non-Binding Contents

Except for the statutes and regulations cited, the contents of this document do not have the force and effect of law and are not meant to bind the States or the public in any way. This document is intended only to provide information regarding existing requirements under the law or agency policies.\*

### Quality Assurance Statement

The Federal Highway Administration (FHWA) provides high-quality information to serve Government, industry, and the public in a manner that promotes public understanding. Standards and policies are used to ensure and maximize the quality, objectivity, utility, and integrity of its information. FHWA periodically reviews quality issues and adjusts its programs and processes to ensure continuous quality improvement.

\*Revised 5/20/2025

## TECHNICAL REPORT DOCUMENTATION PAGE

1. Report No. FHWA-HRT-16-011	2. Government Accession No.	3. Recipient's Catalog No.	
4. Title and Subtitle Using Falling Weight Deflectometer Data with Mechanistic-Empirical Design and Analysis, Volume III: Guidelines for Deflection Testing, Analysis, and Interpretation		5. Report Date December 2017	
		6. Performing Organization Code:	
7. Author(s) Linda M. Pierce, James E. Bruinsma, Kurt D. Smith, Monty J. Wade, Karim Chatti, and Julie M. Vandenbossche		8. Performing Organization Report No.	
9. Performing Organization Name and Address Applied Pavement Technology Inc. 115 West Main Street, Suite 400 Urbana, IL 61801		10. Work Unit No.	
		11. Contract or Grant No. DTFH61-06-C-00046	
12. Sponsoring Agency Name and Address Federal Highway Administration 1200 New Jersey Ave. S.E. Washington, DC 20590-9898		13. Type of Report and Period Covered Final Report; October 2006–December 2010	
		14. Sponsoring Agency Code	
15. Supplementary Notes The FHWA Contracting Officer's Representative was Nadarajah Sivaneswaran.			
16. Abstract <p>The need to accurately characterize the structural condition of existing pavements has increased with the recent development, release, and ongoing implementation of the <i>Mechanistic-Empirical Pavement Design Guide</i> (MEPDG). A number of different material inputs are required in the procedure, and it is important to adequately characterize and define them. The analysis of deflection data collected by the falling weight deflectometer (FWD) provides a quick and reliable way to characterize the properties of the paving layers, as well as to assess the load-carrying capacity of existing pavement structures. With the release of the new MEPDG, there is a pressing need to identify and evaluate the way that FWD testing is integrated into the new design procedure. Moreover, as highway agencies continue to implement the MEPDG, they need best practices guidance on how to effectively test existing pavement structures and interpret the results as part of a mechanistic-empirical pavement evaluation and rehabilitation process.</p> <p>This document is part of a three-volume report investigating the use of the FWD as part of mechanistic-empirical pavement design and rehabilitation procedures. This volume provides best practice guidelines for effective testing of existing pavement structures and interpretation of those results as part of a mechanistic-empirical pavement evaluation and rehabilitation process. Included are guidelines for deflection testing, a discussion of the various data input requirements and suggested default values for backcalculation, a summary of backcalculation modeling issues, and information on measures of convergence and verification of backcalculated results. In addition, general background information is provided on mechanistic-empirical pavement design; data and testing recommendations for project evaluation; and flexible, rigid, and composite pavement inputs.</p> <p>This is volume III of a three-volume report. The other volumes in the series are FHWA-HRT-16-009, Volume I: <i>Final Report</i>, and FHWA-HRT-16-010, Volume II: <i>Case Study Reports</i>.</p>			
17. Key Words Falling weight deflectometer, backcalculation, deflection data, structural evaluation, resilient modulus, elastic modulus, subgrade support, mechanistic-empirical pavement design, rehabilitation design, overlay design		18. Distribution Statement No restrictions. This document is available through the National Technical Information Service, Springfield, VA 22161. <a href="http://www.ntis.gov">http://www.ntis.gov</a>	
19. Security Classif. (of this report) Unclassified	20. Security Classif. (of this page) Unclassified	21. No. of Pages 122	22. Price N/A

# SI\* (MODERN METRIC) CONVERSION FACTORS

## APPROXIMATE CONVERSIONS TO SI UNITS

Symbol	When You Know	Multiply By	To Find	Symbol
<b>LENGTH</b>				
in	inches	25.4	millimeters	mm
ft	feet	0.305	meters	m
yd	yards	0.914	meters	m
mi	miles	1.61	kilometers	km
<b>AREA</b>				
in <sup>2</sup>	square inches	645.2	square millimeters	mm <sup>2</sup>
ft <sup>2</sup>	square feet	0.093	square meters	m <sup>2</sup>
yd <sup>2</sup>	square yard	0.836	square meters	m <sup>2</sup>
ac	acres	0.405	hectares	ha
mi <sup>2</sup>	square miles	2.59	square kilometers	km <sup>2</sup>
<b>VOLUME</b>				
fl oz	fluid ounces	29.57	milliliters	mL
gal	gallons	3.785	liters	L
ft <sup>3</sup>	cubic feet	0.028	cubic meters	m <sup>3</sup>
yd <sup>3</sup>	cubic yards	0.765	cubic meters	m <sup>3</sup>
NOTE: volumes greater than 1000 L shall be shown in m <sup>3</sup>				
<b>MASS</b>				
oz	ounces	28.35	grams	g
lb	pounds	0.454	kilograms	kg
T	short tons (2000 lb)	0.907	megagrams (or "metric ton")	Mg (or "t")
<b>TEMPERATURE (exact degrees)</b>				
°F	Fahrenheit	5 (F-32)/9 or (F-32)/1.8	Celsius	°C
<b>ILLUMINATION</b>				
fc	foot-candles	10.76	lux	lx
fl	foot-Lamberts	3.426	candela/m <sup>2</sup>	cd/m <sup>2</sup>
<b>FORCE and PRESSURE or STRESS</b>				
lbf	poundforce	4.45	newtons	N
lbf/in <sup>2</sup>	poundforce per square inch	6.89	kilopascals	kPa

## APPROXIMATE CONVERSIONS FROM SI UNITS

Symbol	When You Know	Multiply By	To Find	Symbol
<b>LENGTH</b>				
mm	millimeters	0.039	inches	in
m	meters	3.28	feet	ft
m	meters	1.09	yards	yd
km	kilometers	0.621	miles	mi
<b>AREA</b>				
mm <sup>2</sup>	square millimeters	0.0016	square inches	in <sup>2</sup>
m <sup>2</sup>	square meters	10.764	square feet	ft <sup>2</sup>
m <sup>2</sup>	square meters	1.195	square yards	yd <sup>2</sup>
ha	hectares	2.47	acres	ac
km <sup>2</sup>	square kilometers	0.386	square miles	mi <sup>2</sup>
<b>VOLUME</b>				
mL	milliliters	0.034	fluid ounces	fl oz
L	liters	0.264	gallons	gal
m <sup>3</sup>	cubic meters	35.314	cubic feet	ft <sup>3</sup>
m <sup>3</sup>	cubic meters	1.307	cubic yards	yd <sup>3</sup>
<b>MASS</b>				
g	grams	0.035	ounces	oz
kg	kilograms	2.202	pounds	lb
Mg (or "t")	megagrams (or "metric ton")	1.103	short tons (2000 lb)	T
<b>TEMPERATURE (exact degrees)</b>				
°C	Celsius	1.8C+32	Fahrenheit	°F
<b>ILLUMINATION</b>				
lx	lux	0.0929	foot-candles	fc
cd/m <sup>2</sup>	candela/m <sup>2</sup>	0.2919	foot-Lamberts	fl
<b>FORCE and PRESSURE or STRESS</b>				
N	newtons	0.225	poundforce	lbf
kPa	kilopascals	0.145	poundforce per square inch	lbf/in <sup>2</sup>

\*SI is the symbol for the International System of Units. Appropriate rounding should be made to comply with Section 4 of ASTM E380.  
(Revised March 2003)

## TABLE OF CONTENTS

<b>CHAPTER 1. INTRODUCTION</b> .....	<b>1</b>
<b>CHAPTER 2. DEFLECTION TESTING GUIDELINES</b> .....	<b>3</b>
<b>INTRODUCTION</b> .....	<b>3</b>
<b>DEFLECTION TESTING DEVICES</b> .....	<b>3</b>
Static Loading .....	3
Steady-State Loading .....	4
Impulse Loading .....	4
<b>PURPOSE OF DEFLECTION TESTING</b> .....	<b>5</b>
Backcalculation of Deflection Data .....	6
Computed Indices From Deflection Data .....	6
<b>FACTORS AFFECTING DEFLECTIONS</b> .....	<b>15</b>
Pavement Structure .....	15
Pavement Loading .....	16
Climate .....	16
Testing Season .....	16
<b>FWD TESTING GUIDELINES</b> .....	<b>16</b>
Sensor Configuration .....	17
Number of Drops and Load Levels.....	17
Testing Location .....	18
Testing Increments.....	20
Temperature Measurements.....	20
Joint/Crack Opening .....	21
Safety Guidelines .....	22
Summary of FWD Testing Recommendations .....	22
<b>DATA CHECKS</b> .....	<b>23</b>
Types of Errors .....	23
Addressing Deflection Errors .....	24
Addressing Load Errors .....	25
<b>ADDITIONAL SOURCES FOR DEFLECTION TESTING GUIDELINES</b> .....	<b>25</b>
<b>FWD CALIBRATION</b> .....	<b>25</b>
<b>SUMMARY</b> .....	<b>26</b>
<b>CHAPTER 3. GENERAL BACKCALCULATION GUIDELINES</b> .....	<b>27</b>
<b>BACKCALCULATION VERSUS FORWARDCALCULATION</b> .....	<b>27</b>
<b>BACKCALCULATION GUIDELINES</b> .....	<b>27</b>
Inputs Needed for Backcalculation Analysis.....	29
Backcalculation Pavement Model.....	29
Modeling and Response Issues .....	40
Temperature and Moisture Effects.....	41
Slab Size Effects .....	42
Measures of Convergence.....	44
Modulus Convergence .....	45
Identifying Outliers.....	45
Other Effects .....	46

<b>VERIFICATION OF BACKCALCULATION RESULTS .....</b>	<b>46</b>
Comparison Based on Strain.....	46
Laboratory Versus Backcalculated Moduli.....	50
<b>BACKCALCULATION EXAMPLE .....</b>	<b>52</b>
Project Description.....	52
Input Values .....	53
Backcalculation Results .....	54
<b>SUMMARY .....</b>	<b>61</b>
<b>CHAPTER 4. USE OF DEFLECTION DATA IN THE MEPDG .....</b>	<b>67</b>
<b>INTRODUCTION TO MECHANISTIC-EMPIRICAL PAVEMENT DESIGN.....</b>	<b>67</b>
Mechanistic-Empirical Pavement Design Principles .....	67
Flexible Pavement Responses .....	69
Rigid Pavement Responses .....	70
<b>SELECTION OF DEFLECTION-BASED INPUTS FOR THE MEPDG .....</b>	<b>73</b>
<b>PROJECT EVALUATION IN THE MEPDG.....</b>	<b>74</b>
Pavement Condition Evaluation .....	76
Pavement Coring.....	77
Subsurface Boring.....	77
Laboratory Testing.....	77
Other Project Testing .....	78
MEPDG Flexible Pavement Inputs.....	78
HMA Materials .....	79
Chemically Stabilized Materials .....	82
Unbound Materials.....	83
Feasibility of Using Dynamic Backcalculation for Future Versions of the MEPDG .....	84
<b>RIGID PAVEMENT INPUTS IN THE MEPDG .....</b>	<b>85</b>
Effective $k$ -Value .....	85
PCC Parameters .....	90
<b>COMPOSITE (HMA/PCC) PAVEMENT INPUTS IN THE MEPDG.....</b>	<b>90</b>
Effective $k$ -Value .....	91
PCC Parameters .....	92
<b>OTHER USES OF DEFLECTION DATA IN THE MEPDG.....</b>	<b>92</b>
LTE .....	92
Void Detection .....	93
<b>MEPDG INPUTS FOR EVALUATION OF EXISTING PAVEMENT LAYERS .....</b>	<b>93</b>
<b>SUMMARY .....</b>	<b>96</b>
<b>CHAPTER 5. SUMMARY.....</b>	<b>99</b>
<b>GLOSSARY OF TERMS.....</b>	<b>101</b>
<b>REFERENCES.....</b>	<b>107</b>



## LIST OF FIGURES

Figure 1. Diagram. Typical pavement deflection basin.....	3
Figure 2. Photo. Benkelman beam.....	4
Figure 3. Photo. Steady-state deflection device.....	4
Figure 4. Photo. Impulse loading or FWD device.....	5
Figure 5. Equation. AREA method equation for a four-sensor configuration.....	7
Figure 6. Equation. AREA method equation for a seven-sensor configuration.....	7
Figure 7. Chart. Maximum deflection, <i>AREA</i> , and subgrade modulus.....	9
Figure 8. Equation. $F - 1$ shape factor definition.....	10
Figure 9. Equation. BLI definition.....	10
Figure 10. Equation. MLI definition.....	10
Figure 11. Equation. LLI definition.....	10
Figure 12. Equation. RoC definition.....	11
Figure 13. Equation. Surface modulus at center of loading plate ( $E_0$ ) and at distance $r$ ( $E_r$ ).....	12
Figure 14. Equation. Equivalent depth definition.....	12
Figure 15. Diagram. Load transfer concept.....	13
Figure 16. Equation. Deflection-based LTE.....	13
Figure 17. Equation. Stress-based LTE.....	14
Figure 18. Graph. Example void detection plot using deflection data.....	15
Figure 19. Diagram. Illustration of flexible and rigid pavement test plans.....	19
Figure 20. Graph. Inverse of deflection offset versus measured deflection.....	33
Figure 21. Equation. Determination of depth to stiff layer, HMA less than 50 mm (2 inches) thick ( $R^2 = 0.98$ ).....	33
Figure 22. Equation. Determination of depth to stiff layer, HMA 50 to 100 mm (2 to 4 inches) thick ( $R^2 = 0.98$ ).....	33
Figure 23. Equation. Determination of depth to stiff layer, HMA 100 to 150 mm (4 to 6 inches) thick ( $R^2 = 0.94$ ).....	34
Figure 24. Equation. Determination of depth to the stiff layer, HMA greater than 150 mm (6 inches) thick ( $R^2 = 0.97$ ).....	34
Figure 25. Equation. Determination of depth to the stiff layer, HMA greater than 150 mm (6 inches) thick ( $R^2 = 0.97$ ).....	35
Figure 26. Graph. Measured deflection versus $1/r$ .....	35
Figure 27. Equation. Sample computation of depth to the stiff layer with HMA greater than 150 mm (6 inches) thick ( $R^2 = 0.97$ ).....	36
Figure 28. Equation. Determination of depth to the stiff layer using modified Roesset's equations.....	36
Figure 29. Graph. Illustration of natural period, $T_d$ , from sensor deflection time histories.....	37
Figure 30. Equation. Determination of slab modulus values for (a) unbonded and (b) bonded conditions.....	39
Figure 31. Equation. Stress-dependent modulus determination.....	41
Figure 32. Equation. Estimate of radius of relative stiffness for an infinite slab.....	43
Figure 33. Equation. Estimate of modulus of subgrade reaction for an infinite slab.....	43
Figure 34. Equation. Adjustment factor for radius of relative stiffness.....	43
Figure 35. Equation. Adjustment factor for deflection directly under load plate.....	43
Figure 36. Equation. Adjusted $k$ -value calculation for slab size.....	43

Figure 37. Equation. Determination of RMS error .....	44
Figure 38. Equation. Example RMS calculation .....	44
Figure 39. Equation. Determination of modulus convergence .....	45
Figure 40. Graph. Measured versus calculated strain for axial core bottom longitudinal gauges .....	47
Figure 41. Graph. Measured versus calculated strain for axial core bottom transverse gauges .....	47
Figure 42. Graph. Backcalculated versus measured tensile strains (80-mm (3.1-inch) HMA).....	48
Figure 43. Graph. Backcalculated versus measured tensile strains (150-mm (5.9-inch) HMA).....	48
Figure 44. Graph. Comparison of backcalculated (EVERCALC©) and measured AC strain .....	49
Figure 45. Graph. Comparison of backcalculated (WESDEF) and measured AC strain .....	49
Figure 46. Graph. HMA strain comparison .....	50
Figure 47. Diagram. HMA pavement response locations.....	70
Figure 48. Diagrams. Thermal curling stress for (a) day (b) night, and (c) constrained transverse joints .....	72
Figure 49. Diagrams. Critical loading conditions: (a) faulting, (b) bottom-up fatigue cracking, and (c) top-down fatigue cracking .....	73
Figure 50. Diagram. Illustration of HMA modulus correction.....	79
Figure 51. Equation. Undamaged dynamic modulus.....	80
Figure 52. Equation. Estimate of damaged modulus .....	80
Figure 53. Equation. Determination of $\alpha'$ .....	81
Figure 54. Equation. Determination of the field master curve .....	81
Figure 55. Equation. Distress model for top-down cracking.....	81
Figure 56. Graph. Illustration of estimating damage factor using backcalculated base moduli .....	82
Figure 57. Equation. Reduction of backcalculated modulus based on observed conditions .....	83
Figure 58. Diagram. Illustration of the $E$ -to- $k$ conversion process incorporated in the MEPDG.....	86
Figure 59. Diagram. Transforming the actual pavement structure into an equivalent structure for an HMA layer over a PCC slab.....	87
Figure 60. Diagram. Transforming the actual pavement structure into an equivalent structure for an unbonded JPCP/CRCP over a PCC slab .....	87
Figure 61. Diagram. Transforming the actual pavement structure into an equivalent structure for a bonded JPCP/CRCP over a PCC slab .....	88
Figure 62. Diagram. Transforming the actual pavement structure into an equivalent structure for a PCC overlay of an existing HMA pavement.....	89

## LIST OF TABLES

Table 1. Typical <i>AREA</i> values (four-sensor configuration) and $D_0$ .....	7
Table 2. Trends of $D_0$ and <i>AREA</i> values .....	8
Table 3. Benchmark values for deflection bowl parameters BLI, MLI, LLI, and RoC .....	11
Table 4. Summary of LTPP deflection sensor locations, sensor offset .....	17
Table 5. Summary of LTPP load levels and testing (drop) sequence .....	17
Table 6. LTPP Program temperature measurement hole depths.....	21
Table 7. Summary of deflection testing recommendations .....	23
Table 8. Summary of available backcalculation programs .....	28
Table 9. HMA moduli versus temperature .....	30
Table 10. Typical layer moduli for unstabilized materials .....	31
Table 11. Typical layer moduli for stabilized materials .....	32
Table 12. Typical moduli values of various subgrade materials for climate conditions .....	32
Table 13. Typical Poisson's ratio values .....	32
Table 14. Typical and normalized deflection .....	34
Table 15. Values for $1/r$ values (at 40-kN (9,000-lbf) load level).....	35
Table 16. Effects of interface condition.....	38
Table 17. Typical modular ratios ( $\beta$ ) .....	39
Table 18. Seasonal moduli adjustment factors for unbound materials .....	42
Table 19. Example measured and computed pavement deflection data .....	44
Table 20. Backcalculated versus laboratory-obtained subgrade moduli and recommended values for use in the MEPDG .....	51
Table 21. Summary of pavement cross section information.....	53
Table 22. Input values to represent pavement layers .....	54
Table 23. FWD deflections and normalized deflection to 40 kN (9,000 lbf) .....	55
Table 24. Summary of EVERCALC© backcalculation results .....	58
Table 25. Summary of selected layer moduli .....	60
Table 26. Addressing specific conditions in pavement backcalculation analysis .....	63
Table 27. Definition of input levels for pavement evaluation .....	74
Table 28. Damage of existing chemically stabilized modulus based on pavement condition.....	76
Table 29. Damage of existing HMA modulus based on pavement condition .....	76
Table 30. Description of existing PCC pavement condition.....	77
Table 31. Recommended input values for elastic or resilient modulus of chemically stabilized materials.....	83
Table 32. Summary of backcalculated-to-laboratory modulus ratios .....	84
Table 33. Condition factor values used to adjust moduli of intact slabs .....	90
Table 34. Summary of qualitative LTE ratings .....	92
Table 35. Inputs for rehabilitation design using the MEPDG .....	94
Table 36. Use of deflection data in the MEPDG .....	97

## LIST OF ABBREVIATIONS

AASHTO	American Association of State Highway and Transportation Officials
AC	asphalt concrete
BLI	Base Layer Index
BCI	Base Curvature Index
BDI	Base Damage Index
CRCP	continuously reinforced concrete pavement
DCP	dynamic cone penetrometer
EICM	Enhanced Integrated Climatic Model
ESAL	equivalent single-axle load
FEM	finite element modeling
FHWA	Federal Highway Administration
FWD	falling weight deflectometer
GPR	ground-penetrating radar
HMA	hot-mix asphalt
IE	impact echo
IR	impulse response
IRI	International Roughness Index
JPCP	jointed plain cement concrete pavement
LLI	Lower Layer Index
LTE	load transfer efficiency
LTPP	Long-Term Pavement Performance (program)
MEPDG	<i>Mechanistic-Empirical Pavement Design Guide</i>
MLI	Middle Layer Index
MP	milepost
NCHRP	National Cooperative Highway Research Program
NDT	nondestructive testing
PCA	Portland Cement Association
PCC	portland cement concrete
RMS	root mean square
RoC	radius of curvature
SASW	seismic analysis of surface waves
SCI	Surface Curvature Index
VTS	viscosity temperature susceptibility

## CHAPTER 1. INTRODUCTION

The need to accurately characterize the structural condition of existing pavements has increased with the ongoing development of mechanistic-empirical thickness design procedures and particularly with the release of the *Mechanistic-Empirical Pavement Design Guide* (MEPDG) prepared under National Cooperative Highway Research Program (NCHRP) Project 1-37A.<sup>(1,2)</sup> In the MEPDG, the performance of the pavement being designed is projected by simulating the expected accumulated damage on a monthly or semimonthly basis over the selected design period. The amount of incremental damage occurring during each computation interval (either monthly or semimonthly) varies as the effects of prevailing environmental conditions, changes in material properties, and effects of traffic loading are directly considered. Ultimately, the incremental damage accumulated during each computation interval is converted into the development of physical pavement distresses and projected roughness levels using calibrated performance models.<sup>(1,2)</sup>

An integral part of this process is the accurate characterization of material parameters of each layer in the pavement structure. Deflection data collected by the falling weight deflectometer (FWD) can be used to characterize the parameters of the paving layers through backcalculation, in which the engineering material parameters of the paving layers (elastic modulus,  $E$ , or dynamic modulus,  $E^*$ ) and underlying soil (resilient modulus,  $M_R$ , or modulus of subgrade reaction,  $k$ ) are estimated based on the measured surface deflections, the magnitude of the load, and information on the pavement layer thicknesses. In essence, the set of characteristics for the paving layers and subgrade material is determined such that it produces a pavement response that best matches the measured deflections under the known loading conditions.

Taken as a whole, pavement deflection data can be used in a number of ways, including the following:

- Evaluate maximum deflections normalized to a standard load.
- Backcalculate material parameters of pavement layers.
- Evaluate subgrade support conditions.
- Assess potential areas of localized weakness.
- Assess the degree of deterioration in the pavement structure.
- Determine structural enhancement requirements (overlay thickness).
- Determine structural remaining life for projected traffic loadings.
- Evaluate the structural capacity of the pavement structure.
- Develop load limits and/or seasonal load restrictions.
- Determine the presence of built-in upward curling (for rigid pavements).

Over the years, researchers and practitioners have developed numerous approaches to backcalculate pavement layer and subgrade moduli, as well as numerous programs to perform the calculations, in ongoing efforts to better characterize the material properties of the existing pavement structure.

This report provides best practice guidelines for deflection testing of existing pavement structures, as well as recommended backcalculation techniques and data interpretation

procedures to analyze those results as part of a mechanistic-empirical pavement evaluation and rehabilitation process. The focus of the report is the use of the FWD because it is the most commonly used deflection testing device.

In addition to this chapter, this guideline report consists of the following:

- **Chapter 2:** A general overview of deflection testing, including a summary of various factors that affect deflection testing results and general guidelines for conducting a deflection testing program.
- **Chapter 3:** General guidelines for backcalculation, including a discussion of the various data input requirements and suggested default values for backcalculation, an overview of backcalculation modeling issues, methods for assessing convergence and verification of backcalculated results, and a presentation of a backcalculation example.
- **Chapter 4:** General background information on mechanistic-empirical pavement design, while also providing specific data and testing recommendations for project evaluation, and flexible, rigid, and composite pavement inputs in the new MEPDG.
- **Chapter 5:** Overall summary of the report.
- **Glossary:** List of terms and their definitions.

## CHAPTER 2. DEFLECTION TESTING GUIDELINES

### INTRODUCTION

Pavement deflection testing is a quick and easy way to assess the structural condition of an in-service pavement in a nondestructive manner. Over the years, a variety of deflection testing equipment has been used for this purpose, from simple beam-like devices affixed with mechanical dial gauges to more sophisticated equipment using laser-based technology. Nevertheless, all pavement deflection testing equipment basically operates in the same manner—a known load is applied to the pavement, and the resulting maximum surface deflection or an array of surface deflections located at fixed distances from the load, known as a deflection basin, are measured. Figure 1 is a schematic of a deflection basin.

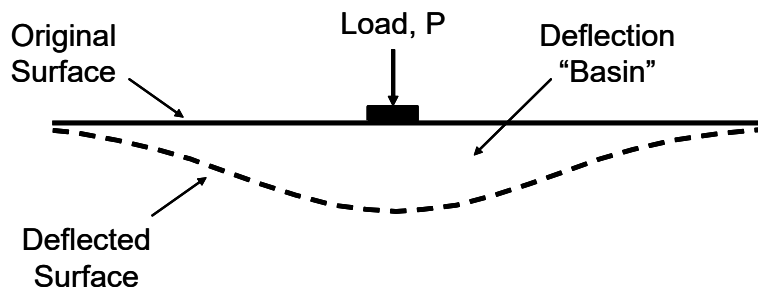

**Figure 1. Diagram. Typical pavement deflection basin.**

This chapter reviews various deflection testing equipment, presents the reasons for conducting deflection testing, describes common deflection testing patterns, discusses important factors influencing deflection measurements, and provides guidelines for conducting deflection testing.

### DEFLECTION TESTING DEVICES

In general, there are three primary methods for conducting deflection testing: static loading, steady-state loading, and impulse loading. The following subsections describe the fundamentals of each of these testing methods, their shortcomings, and their benefits.

#### Static Loading

The primary device used in the static loading method is the Benkelman beam. The Benkelman beam device is based on level arm principles, where the tip of the device is placed between the dual tires of a single axle loaded to 80 kN (18,000 lbf), and the tires are inflated to 480 to 550 kPa (70 to 80 lbf/inch<sup>2</sup>) (see figure 2). The operator records the dial measurement as the pavement rebounds from the weight of the axle as the truck is moved forward. Limitations of the Benkelman beam include its inability to measure a deflection basin and only the maximum surface deflection, its relatively labor-intensive requirements for use, and its slow rate of testing that requires traffic control for stopped conditions. Perhaps the primary benefit of the Benkelman beam is that it is relatively inexpensive.



Photo courtesy of John Harvey.

**Figure 2. Photo. Benkelman beam.<sup>(3)</sup>**

### **Steady-State Loading**

In steady-state loading, a nonchanging vibration using a dynamic force generator is applied to the pavement surface, and deflections are measured using velocity transducers. Devices that incorporate steady-state loading (see figure 3) can measure deflection basin. Because of the lighter loading, steady-state deflection devices are suitable for thinner pavements. These devices require traffic control during deflection testing.



Photo courtesy of John Harvey.

**Figure 3. Photo. Steady-state deflection device.<sup>(3)</sup>**

### **Impulse Loading**

Impulse loading is conducted by dropping weights at various drop heights to apply an impulse load, ranging from 6.7 to 120 kN (1,500 to 27,000 lbf), to the pavement surface. Deflections are measured using seismometers, velocity transducers, or accelerometers. Devices of this type—



known as FWDs and are available through various manufacturers—are capable of measuring a deflection basin and more closely simulate truck traffic loading (see figure 4). As with steady-state testing devices, traffic control is required with FWDs.



**Figure 4. Photo. Impulse loading or FWD device.**

Because the majority of State transportation departments use the FWD for deflection testing, that device is the focus of this report.<sup>(4)</sup>

## **PURPOSE OF DEFLECTION TESTING**

The primary purpose of deflection testing is to determine the structural adequacy of an existing pavement and to assess its capability of handling future traffic loadings. As observed in the early work by Hveem, there is a strong correlation between pavement deflections (an indicator of the structural adequacy of the pavement) and the ability of the pavement to carry traffic loadings at a prescribed minimum level of service.<sup>(5)</sup> This early work attempted to identify maximum deflection limits below which pavements were expected to perform well; these limits were based on experience and observations of performance of similar pavements. This concept quickly lent itself to overlay design, in which the required overlay thicknesses could be determined based on trying to reduce maximum pavement deflections to tolerable levels.

When complete deflection basins are available, deflection testing can provide key parameters for the existing pavement structure through backcalculation of the measured pavement responses. Specifically, for hot-mix asphalt (HMA) pavements, the elastic modulus ( $E$ ) of the individual paving layers can be determined, along with the resilient modulus ( $M_R$ ) of the subgrade. For portland cement concrete (PCC) pavements, the elastic modulus ( $E$ ) of the PCC slab and the modulus of subgrade reaction ( $k$ ) can be determined. In addition, deflection testing conducted on PCC pavements can be used to estimate the load transfer efficiency (LTE) across joints or cracks as well as for the identification of loss of support at slab corners.

These parameters of the pavement layers and of the subgrade are used in pavement design procedures or in performance prediction models to estimate the remaining life or load-carrying capacity of the pavement. They can also be used in elastic layer or finite element programs to compute stresses and strains in the pavement structure and are also direct inputs in many overlay design procedures to determine the required overlay thickness needed for the current pavement condition and the anticipated future traffic loadings.

Deflection data can also be used in other ways to help characterize the condition of the existing pavement. For example, plots of deflection data along a pavement project can be examined for nonuniformity, which may suggest areas that require further investigation using other means, including destructive sampling and testing (see the section later in this report titled Computed Indices from Deflection Data). In addition, daily or seasonal deflection data can provide insight into a pavement's response to environmental forces, including the effects of thermal curling, frozen support conditions, and asphalt stiffening. Some agencies also use deflection criteria to establish seasonal load restrictions for certain low-volume roads. Deflection testing has also seen some limited use as a means of monitoring the quality of a pavement during construction.<sup>(6)</sup> Finally, a few agencies conduct deflection testing at the network level to provide a general indication of the structural capacity of the pavement structure.

### **Backcalculation of Deflection Data**

As described previously, pavement deflection data can be analyzed in a number of ways to help provide detailed information about a specific pavement. Perhaps the most common use of deflection data is in the backcalculation process through which the fundamental engineering properties of the pavement structure, such as the modulus values of the paving layers and the subgrade, are determined. An underlying assumption in the backcalculation process is that a set of layer modulus values exists that produces the measured deflections under the applied load. It is important to note, however, that the solution may not be unique. To obtain good results, engineering judgment must be used to ensure that the modulus value selected for each layer is within a reasonable range for the material type. Backcalculation results can be highly variable owing to variability in pavement condition, subsurface condition, material properties, and pavement structure along the project.

Different backcalculation methodologies are employed for flexible and rigid pavements, but even for a specific pavement type, a number of different approaches can be used. Common procedures include iterative methods, closed-form solutions (currently available for two-layer pavement systems), and simultaneous equations (using nonlinear regression equations). However, varying results can be obtained from these approaches because of differences in the way the pavement structure is modeled. Chapter 3 provides more detailed information on recommended backcalculation procedures and approaches for both flexible and rigid pavements.

### **Computed Indices From Deflection Data**

A number of deflection-based indices are often computed as a means of characterizing some aspect of the existing pavement structure. A few of the more common indices are described in the following subsections.

### *AREA Method*

Hoffman and Thompson first introduced the AREA method to characterize the deflection basin for a simple two-parameter backcalculation procedure for flexible pavements, but its use has been expanded to rigid pavements as well.<sup>(7)</sup> The AREA method represents the normalized area of a vertical slice through a deflection basin between the center of the test load and at varying radial distances from the test load. For a four-sensor configuration, the AREA method equation is shown in figure 5.

$$AREA_{36} = 6 \left( 1 + 2 \frac{d_{12}}{d_0} + 2 \frac{d_{24}}{d_0} + \frac{d_{36}}{d_0} \right)$$

**Figure 5. Equation. AREA method equation for a four-sensor configuration.**

Where:

$d_0$  = Surface deflection at center of test load (inches).

$d_{12}$  = Surface deflection at a distance of 300 mm (12 inches) from load.

$d_{24}$  = Surface deflection at a distance of 600 mm (24 inches) from load.

$d_{36}$  = Surface deflection at a distance of 900 mm (36 inches) from load.

The AREA method equation for a seven-sensor configuration is shown in figure 6:

$$AREA_{60} = 4 + 6 \cdot \frac{d_8}{d_0} + 5 \cdot \frac{d_{12}}{d_0} + 6 \cdot \frac{d_{18}}{d_0} + 9 \cdot \frac{d_{24}}{d_0} + 18 \cdot \frac{d_{36}}{d_0} + 12 \cdot \frac{d_{60}}{d_0}$$

**Figure 6. Equation. AREA method equation for a seven-sensor configuration.**

Where:

$d_8$  = Surface deflection at a distance of 203 mm (8 inches) from load.

$d_{18}$  = Surface deflection at a distance of 457 mm (18 inches) from load.

$d_{60}$  = Surface deflection at a distance of 1,219 mm (48) inches from load.

Typical *AREA* values (four-sensor configuration) and  $D_0$ , the surface deflection at the center of test load (in mm (inches)) are shown in table 1, while typical trends are shown in table 2.

**Table 1. Typical *AREA* values (four-sensor configuration) and  $D_0$ .**

<b>Pavement Type</b>	<b><i>AREA</i> Value (mm)</b>	<b><i>AREA</i> Value (inches)</b>	<b><math>D_0</math> (<math>\mu</math>m)</b>	<b><math>D_0</math> (mil)</b>
PCC	740–810	29–32	250–500	10–20
Thick HMA, $\geq$ 200 mm (4 inches)	530–760	21–30	500–1,000	20–40
Thin HMA, $\leq$ 200 mm (4 inches)	410–530	16–21	760–1,200	30–50
Chip seal	380–430	15–17	760–1,200	30–50
Weak chip seal	300–380	12–15	1,000– 1,500	40–60

**Table 2. Trends of  $D_0$  and *AREA* values.**

<i>AREA</i> Value	Maximum Surface Deflection ( $D_0$ )	Generalized Conclusions <sup>1</sup>
Low	Low	Weak structure, strong subgrade
Low	High	Weak structure, weak subgrade
High	Low	Strong structure, strong subgrade
High	High	Strong structure, weak subgrade

<sup>1</sup>Exceptions can occur.

As demonstrated in figure 7, plotting maximum deflection, *AREA* value, and subgrade can be used further for identifying areas needing further investigation, coring, or additional testing and analysis. In figure 7, the HMA layer thickness for the pavement section considered is greater than 150 mm (4 inches), which indicates a lower than expected *AREA* value has been determined for this thickness of pavement (refer to table 1 and table 2). Looking at the maximum center deflection, a higher deflection occurs over the first half of the project length and corresponds to lower subgrade modulus; conversely, lower maximum deflections are noted from milepost (MP) 211.50 to MP 211.05, with corresponding higher subgrade moduli. Coordinating the type of the plot shown in figure 7 with a pavement conditions survey can also be beneficial and assist in determining locations for any needed coring, boring, and additional material sampling.

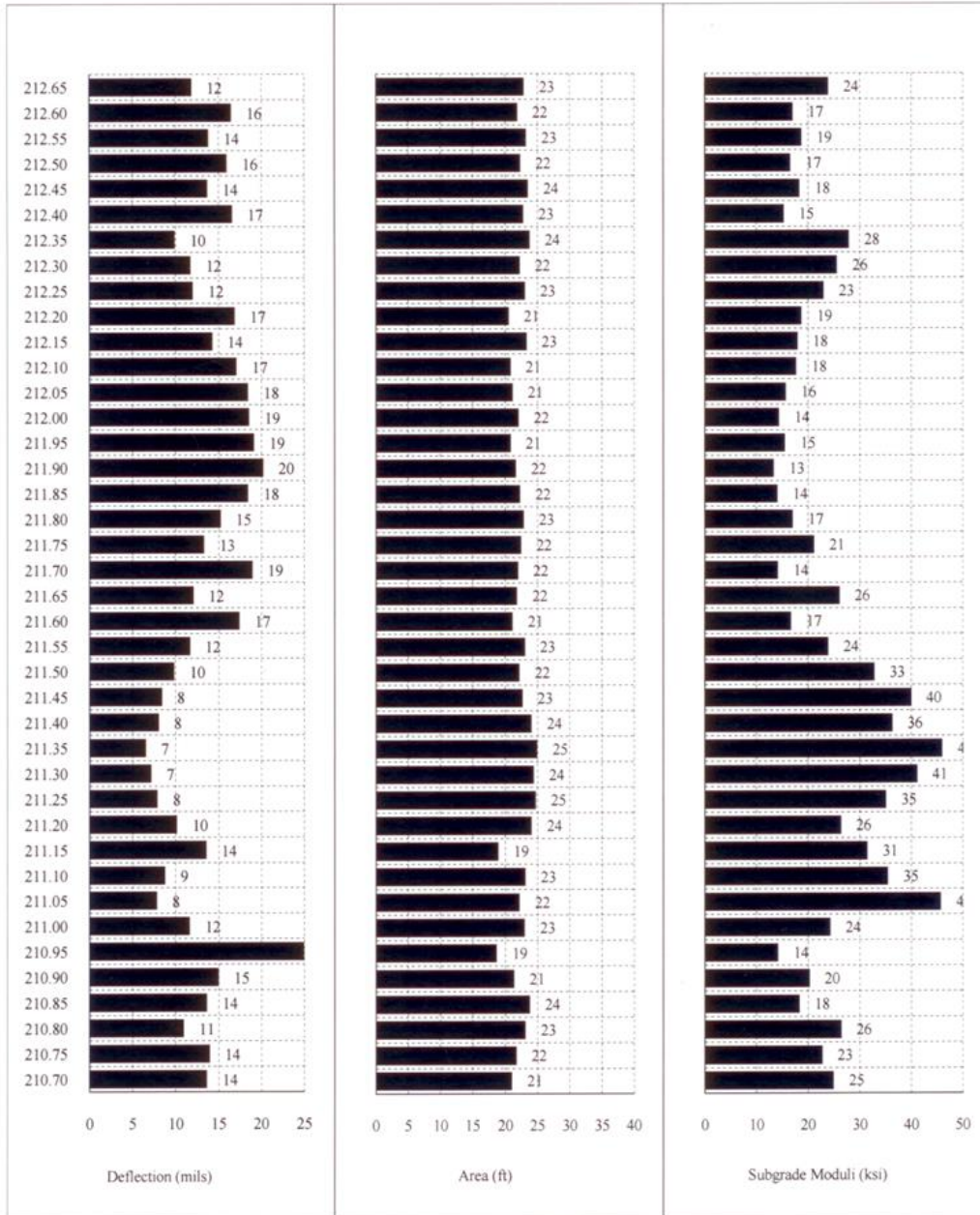

©Washington State Department of Transportation.

1 mil = 0.0254 mm.

1 ft = 0.305 m.

1 ksi = 6,895 MPa.

**Figure 7. Chart. Maximum deflection, AREA, and subgrade modulus.<sup>(8)</sup>**

### *F – 1 Shape Factor*

The  $F - 1$  shape factor represents the amount of deflection basin curvature and is inversely proportional to the ratio of the pavement stiffness to the subgrade stiffness.<sup>(9)</sup> The  $F - 1$  shape factor is defined by the equation in figure 8:

$$F - 1 = \frac{(D_0 - D_2)}{D_1}$$

**Figure 8. Equation.  $F - 1$  shape factor definition.**

Where:

$D_1$  = Surface deflection at a distance of 300 mm (12 inches) from load (mm (inches)).

$D_2$  = Surface deflection at a distance of 600 mm (24 inches) from load (mm (inches)).

***Base Layer Index***

The Base Layer Index (BLI), sometimes referred to as the Surface Curvature Index (SCI), gives an indication of the structural condition of the base layer.<sup>(10)</sup> Figure 9 shows the equation for BLI.

$$BLI = D_0 - D_{300}$$

**Figure 9. Equation. BLI definition.**

Where:

$D_{300}$  = Surface deflection at a distance of 300 mm (12 inches) from load (mm (inches)).

***Middle Layer Index***

The Middle Layer Index (MLI), also referred to as the Base Curvature Index (BCI), provides an indication of the subbase structural condition.<sup>(10)</sup> Figure 10 shows the equation for MLI.

$$MLI = D_{300} - D_{600}$$

**Figure 10. Equation. MLI definition.**

Where:

$D_{600}$  = Surface deflection at a distance of 600 mm (24 inches) from load (mm (inches)).

***Lower Layer Index***

The Lower Layer Index (LLI), also referred to as the Base Damage Index (BDI), provides an indication of the structural condition of the subgrade layers.<sup>(10)</sup> Figure 11 shows the equation for LLI.

$$LLI = D_{600} - D_{900}$$

**Figure 11. Equation. LLI definition.**

Where:

$D_{900}$  = Surface deflection at a distance of 900 mm (36 inches) from load (mm (inches)).

### *Radius of Curvature*

The radius of curvature (RoC) was developed in South Africa and provides an indication of the structural condition of the surface and base course.<sup>(10)</sup> Figure 12 shows the equation for RoC.

$$RoC = \frac{L^2}{2D_0 \left( 1 - D_{200}/D_0 \right)}$$

**Figure 12. Equation. RoC definition.**

Where:

$L = 200$  mm (8 inches).

$D_{200}$  = Surface deflection at a distance of 200 mm (8 inches).

For BLI, MLI, LLI, and RoC, Horak and Emery determined benchmark classification for various flexible pavement sections (see table 3).<sup>(10)</sup>

**Table 3. Benchmark values for deflection bowl parameters BLI, MLI, LLI, and RoC.<sup>(10)</sup>**

<b>Pavement Section</b>	<b>Structural Condition Rating</b>	<b><math>D_0</math> (<math>\mu\text{m}</math>)</b>	<b><math>RoC</math> (<math>\mu\text{m}</math>)</b>	<b><math>BLI</math> (<math>\mu\text{m}</math>)</b>	<b><math>MLI</math> (<math>\mu\text{m}</math>)</b>	<b><math>LLI</math> (<math>\mu\text{m}</math>)</b>
Granular base	Sound	< 500	> 100	< 200	< 100	< 50
	Warning	500–750	50–100	200–400	100–200	50–100
	Severe	> 750	< 50	> 400	> 200	> 100
Cementitious base	Sound	< 200	> 150	< 100	< 50	< 40
	Warning	200–400	80–150	100–300	50–100	40–80
	Severe	> 400	< 80	> 300	> 100	> 80
Bituminous base	Sound	< 400	> 250	< 200	< 100	< 50
	Severe	400–600	100–250	200–400	100–150	50–80
	Warning	> 600	< 100	> 400	> 150	> 80

1 inch = 25.4 mm.

### *Surface Modulus*

The plot of the surface modulus ( $E_0$ ) can be used to provide an indication of the layer stiffness at different equivalent depths.<sup>(11)</sup>  $E_0$ , at an equivalent depth ( $r$ ), approximates a combined modulus of the underlying layers. For values of  $r$  that are greater than the total pavement equivalent thickness,  $E_0$  is approximately equal to the subgrade modulus. The equations for  $E_0$  are shown in figure 13.

$$E_0 = \left[ \frac{2 \times (1 - \nu^2) \times \sigma_0 \times a}{d_r} \right]$$

$$E_r = \left[ \frac{(1 - \nu^2) \times \sigma_0 \times a^2}{r \times d_r} \right]$$

**Figure 13. Equation. Surface modulus at center of loading plate ( $E_0$ ) and at distance  $r$  ( $E_r$ ).**

Where:

$E_0$  = Surface modulus at the center of the loading plate (MPa (lbf/inch<sup>2</sup>)).

$E_r$  = Surface modulus at a distance  $r$  (MPa (lbf/inch<sup>2</sup>)).

$\nu$  = Poisson's ratio.

$\sigma_0$  = Contact pressure under the loading plate (MPa (lbf/inch<sup>2</sup>)).

$a$  = Radius of loading plate (mm (inches)).

$r$  = Distance from sensor to loading center (mm (inches)).

$d_r$  = Deflection at distance  $r$  (mm (inches)).

The equation for equivalent depth is shown in figure 14:

$$h_{e,n} = f_i \left[ h_1^3 \sqrt{\frac{E_1}{E_2}} + h_2^3 \sqrt{\frac{E_2}{E_3}} + \dots h_{n-1}^3 \sqrt{\frac{E_{n-1}}{E_n}} \right]$$

**Figure 14. Equation. Equivalent depth definition.**

Where:

$h_{e,n}$  = Equivalent depth (mm (inches)).

$f_i$  = Factor (0.8–1.0, depending on the modular ratio, thickness, and number of layers).

$h_i$  = Thickness of layer  $i$  (mm (inches)).

$E_i$  = Stiffness modulus of layer  $i$  (MPa (lbf/inch<sup>2</sup>)).

$E_n$  = Stiffness modulus of layer  $n$  (MPa (lbf/inch<sup>2</sup>)).

### ***LTE***

LTE is a parameter that can be computed from deflection testing to characterize the ability of joints and cracks in rigid pavements to effectively transmit load from one side of the joint or crack to the next (see figure 15). This can be done in the field with an FWD by applying a load on one side of the joint or crack and measuring the deflections on the loaded and unloaded slabs under that loading.



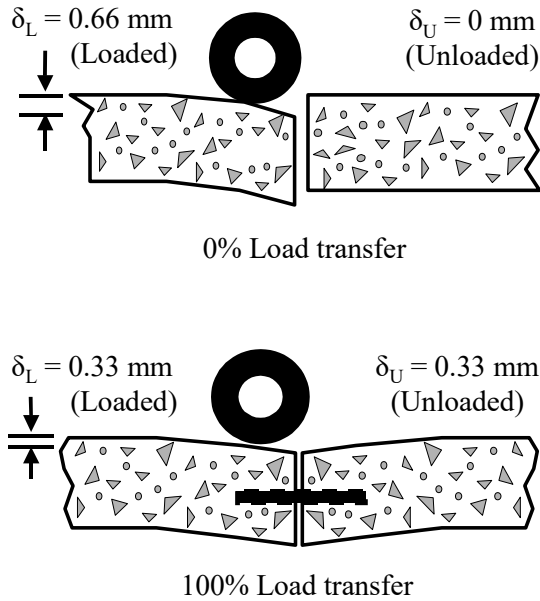

©National Highway Institute  
 1 mm = 39.3 mil.  
 $\delta_L$  = Deflection at loaded slab edge.  
 $\delta_U$  = Deflection at unloaded slab edge.

**Figure 15. Diagram. Load transfer concept.<sup>(12)</sup>**

The equation in figure 16 is used to express deflection-based LTE.

$$LTE = \beta \frac{d_u}{d_l}$$

**Figure 16. Equation. Deflection-based LTE.**

Where:

- $LTE$  = Load transfer efficiency (percent).
- $\beta = d_{0center}/d_{12center}$ , slab bending correction factor.
- $d_u$  = Deflection on the unloaded slab (mm (inches)).
- $d_l$  = Deflection on the loaded slab (mm (inches)).

In theory, the slab bending correction factor ( $\beta$ ) is necessary because the deflections  $d_0$  and  $d_{12}$ , measured 305 mm (12 inches) apart, would not be equal even if measured in the interior of the slab. However, this correction factor is somewhat controversial and is not always used.

The LTE definition given above is based on deflections, but LTE is sometimes defined in terms of stress as shown in figure 17.

$$LTE_{\sigma} = \frac{\sigma_u}{\sigma_l} 100$$

**Figure 17. Equation. Stress-based LTE.**

Where:

$LTE_{\sigma}$  = Stress LTE (percent).

$\sigma_u$  = Corresponding stress at the joint of the unloaded slab (MPa (lbf/inch<sup>2</sup>)).

$\sigma_l$  = Maximum stress at the joint of the loaded slab (MPa (lbf/inch<sup>2</sup>)).

Because deflections can be easily measured in the field, and because stress-based LTE is much more affected by geometry of the applied load than deflection LTE, the deflection-based LTE is the more commonly used expression for LTE.

The theoretical deflection-based LTE ranges from 0 percent (no deflection on the unloaded slab) to 100 percent (equal deflections on the loaded and unloaded slabs). Generally speaking, the following guidelines can be used to define different levels of deflection LTE:<sup>(1)</sup>

- **Excellent:** 90 to 100 percent.
- **Good:** 75 to 89 percent.
- **Fair:** 50 to 74 percent.
- **Poor:** 25 to 49 percent.
- **Very Poor:** 0 to 24 percent.

### *Void Detection*

Pumping of underlying foundation materials (i.e., base, subbase, and subgrade) from beneath a concrete slab can lead to loss of support or voids at slab corners. Although small (typically 0.25 mm (0.01 inches) or smaller), these voids can lead to significant pavement deterioration, such as faulting and corner breaks.

One method of detecting voids beneath concrete slabs is based on the analysis of corner deflections under variable loads.<sup>(13)</sup> In this method, corner deflections are measured at three load levels, and the results are plotted to establish a load-deflection relationship at each corner, as shown in figure 18, which is adapted from figure III-5 in *Joint Repair Methods for Portland Cement Concrete Pavements*.<sup>(13)</sup> The figure illustrates an example in which, for the approach joint, the load-deflection line crosses the x-axis close to 0 at 0.051 mm (0.002 inches). For the leave joint, the load-deflection line crosses the deflection axis at a much greater distance away from the origin, indicating greater deflections under the same load. A line crossing the deflection axis at a point greater than 0.076 mm (0.003 inches or 3 mil) suggests the potential for a void under the slab.

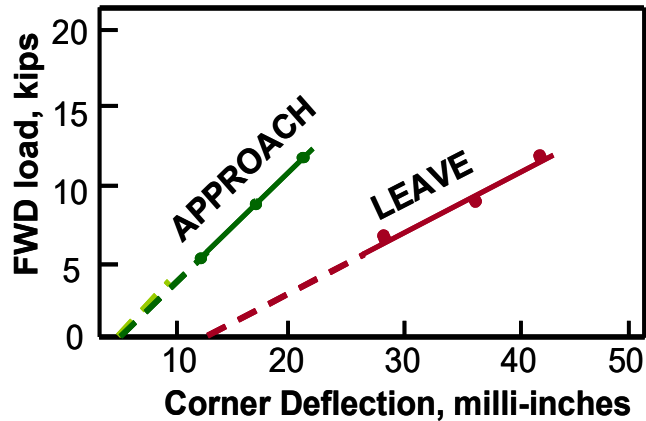

©National Academy of Sciences. Reproduced with permission of the Transportation Research Board.

1 kip = 453.6 kg.

1 milli-inch (mil) = 0.0254 mm.

**Figure 18. Graph. Example void detection plot using deflection data.<sup>(13)</sup>**

To ensure that built-in curling of the concrete slab is not presenting a false indication of voids, deflection testing should not be conducted in the early morning when pavement slabs are typically exposed to negative temperature gradients. Higher midday temperatures should also be avoided during deflection testing to minimize the possibility of joint lockup and slab curl.

## FACTORS AFFECTING DEFLECTIONS

A number of factors affect the magnitude of measured pavement deflections, which can make the interpretation of deflection results difficult. To the extent possible, direct consideration of these factors should be an integral part of the deflection testing process so that the resultant deflection data are meaningful and representative of actual conditions. Recognizing and accounting for these factors before the establishment of a field testing program helps ensure the collection of useful deflection data that can be used in subsequent backcalculation analyses.<sup>(14)</sup> The major factors that affect pavement deflections include pavement structure (type and thickness), pavement loading (load magnitude and type of loading), and climate (temperature and seasonal effects). Each of these is discussed briefly in the following subsections.

### Pavement Structure

The deflection of a pavement represents an overall system response of the surface, base, and subbase layers, as well as the subgrade itself. Thus, the parameters of the surface layer (thickness and stiffness) and of the supporting layers (thickness and stiffness) all affect the magnitude of the measured deflections. Generally speaking, weaker systems deflect more than stronger systems under the same load, with the exact shape of the deflection basin related to the stiffness of the individual paving layers.<sup>(12)</sup> Other pavement-related factors that can also affect deflections include the following:

- Testing near joints, edges, or cracks or in areas containing structural distress (such as alligator cracking), can produce higher deflections than testing at interior portions of the pavement.

- Random variations in pavement layer thickness can create variability in deflection.
- Variations in subgrade parameters and the presence of underlying rigid layers (such as bedrock/stiff layer or a high water table level) can provide significant variability in deflections.

## **Pavement Loading**

One of the most obvious factors that affects pavement deflections is the magnitude of the applied load. Most modern deflection equipment can impose load levels from as little as 13 kN (3,000 lbf) to more than 245 kN (55,000 lbf), and it is important to target appropriate load levels for each application. The type of loading can also affect pavement deflection—a slow, static loading condition produces a different response than a rapid, dynamic loading condition. In general, the more rapid the loading, the shorter the load pulse, and the smaller the deflections.

## **Climate**

Temperature is a very important factor that must be considered as part of any pavement deflection testing program. In HMA pavements, the stiffness of the asphalt layer decreases as the temperature increases, resulting in larger deflections. Therefore, correction of the measured deflections to a standard temperature (commonly 21 °C (70 °F)) is required to perform meaningful interpretations of the data. Deflections on PCC pavements are also affected by temperature because differences in temperature between the top and bottom of the slab cause the slab to curl either upward (i.e., when the slab surface is cooler than the slab bottom) or downward (i.e., when the slab surface is warmer than the slab bottom). If basin testing is conducted when the slab is curled down or if the corner testing is conducted when the slab is curled up, the slab could be unsupported and greater deflections may result. Temperature also affects joint and crack behavior in PCC pavements. Warmer temperatures cause the slabs to expand and, coupled with slab curling effects, may lock up the joints. Deflection testing conducted at joints when they are locked up results in lower joint deflections and higher load transfer efficiencies, which are misleading regarding the overall load transfer capabilities of the joint.

## **Testing Season**

Seasonal variations in temperature and moisture conditions also affect pavement deflection response. Generally speaking, deflections are greatest in the spring because of saturated conditions and reduced pavement support and are lowest in the winter when the underlying layers and subgrade are frozen. PCC pavements are less affected by seasonal variations in support conditions.

## **FWD TESTING GUIDELINES**

The guidelines discussed in the following subsections are related to the physical testing equipment configuration (such as sensor locations and load levels), as well as the type and location of deflection data that are obtained during FWD testing. The discussion of equipment configuration is as generic as possible but may reflect specific capabilities found in the Dynatest® FWD equipment because this equipment is used in the Long-Term Pavement Performance (LTPP) Program.<sup>(15)</sup>

## Sensor Configuration

The LTPP Program’s nine-sensor configuration is recommended for most routine roadway testing, but other configurations are also acceptable as long as the sensor configuration is known when analyzing the deflection data. The advantage to nine sensors is the ability to perform PCC joint or crack LTE testing without relocating a sensor from the HMA testing configuration. Table 4 presents commonly used seven- and nine-sensor LTPP configurations.<sup>(14)</sup>

**Table 4. Summary of LTPP deflection sensor locations, sensor offset.<sup>(14)</sup>**

<b>Deflection Sensor</b>	<b>Nine Sensors (mm (inches))</b>	<b>Seven Sensors (HMA) (mm (inches))</b>	<b>Seven Sensors (PCC) (mm (inches))</b>
D1	0	0	0
D2	203 (8)	203 (8)	-305 (-12)
D3	305 (12)	305 (12)	305 (12)
D4	457 (18)	457 (18)	457 (18)
D5	610 (24)	610 (24)	610 (24)
D6	914 (36)	914 (36)	914 (36)
D7	1,219 (48)	1,524 (60)	1,524 (60)
D8	1,524 (60)	N/A	N/A
D9	-305 (-12)	N/A	N/A

N/A = Not applicable.

## Number of Drops and Load Levels

The LTPP Program recommends multiple drops at different load levels for both HMA and PCC pavements. The different load levels vary the mass of the weight package or release it from different heights. The designated drop heights, target load, acceptable load range, and drop sequence for each pavement type are summarized in table 5.

**Table 5. Summary of LTPP load levels and testing (drop) sequence.<sup>(14)</sup>**

<b>Height Designation</b>	<b>Target Load (kN (lbf))</b>	<b>Acceptable Range (kN (lbf))</b>	<b>No. of HMA Drops<sup>a</sup></b>	<b>No. of PCC Drops<sup>a</sup></b>
Seating <sup>b</sup>	N/A	N/A	3	3
1 <sup>c</sup>	26.7 (6,000)	24.0–29.4 (5,400–6,600)	4	N/A
2	40.0 (9,000)	36.0–44.0 (8,100–9,900)	4	4
3	53.4 (12,000)	48.1–58.7 (10,800–13,200)	4	4
4	71.2 (16,000)	64.1–78.3 (14,400–17,600)	4	4

<sup>a</sup>The last drop of each recorded set contains full load history data.

<sup>b</sup>Seating drop data are not recorded in project data; drop is performed at height 3.

<sup>c</sup>Height 1 is not used for testing PCC pavements.

N/A = Not applicable.

The multiple drops per load level allows checking of uniformity (or variation) of the applied load and deflections. Multiple load levels also allow evaluation of nonlinear material behavior and, for PCC pavements, can be used to evaluate the potential for voids beneath slab corners. The LTPP Program testing protocol also requires seating drops (data are not collected) and a complete time history of the drop is required for the fourth drop in the testing sequence.

In deflection testing outside of the LTPP data collection program, multiple drops at each load level are often not performed so that testing productivity is increased and lane closure times are reduced. ASTM D4694, “Standard Test Method for Deflections with a Falling-Weight-Type Impulse Load Device,” recommends that at least two drops be performed, whereas the American Association of State Highway and Transportation Officials (AASHTO) T 256, *Standard Method of Test for Pavement Deflection Measurements* and ASTM D4695, “Standard Guide for General Pavement Deflection Measurements” suggests one or more drops at any load level.<sup>(16-18)</sup> AASHTO T 256 and ASTM D4695 also indicate that seating drops should be recorded for the analysis of pavement conditioning and further suggests that multiple load levels be used to evaluate nonlinear behavior.<sup>(17,18)</sup>

Based on review of the various testing protocols and studies, a test sequence of four drops at varying load magnitudes is recommended. The first drop should be a seating drop, and the next three drops should be recorded data at 27-, 40-, and 53-kN (6,000-, 9,000-, and 12,000-lbf) target loadings. This test sequence reduces the time at each test location, allows assessment of nonlinear material behavior, and can be used for evaluating the potential for voids under PCC pavements, but it does not allow for repeatability analysis. Moreover, the use of the 27- to 53-kN (6,000–12,000-lbf) load range is recommended because heavier loadings often result in lower backcalculated moduli for granular and subgrade materials.<sup>(1)</sup>

The LTPP Program drop sequence presented in table 5 should be considered for some test locations to provide repeatability analysis, such as at the beginning of testing, end of testing, and every 100 test locations (or a minimum of 3 repeatability test locations per project). Recording the time history for at least the last drop is recommended.

### **Testing Location**

FWD testing locations generally consist of basin tests for flexible and rigid pavements and tests at joints (either midpanel along the joint or at the slab corner) or cracks for rigid pavements. Basin tests are used for backcalculating pavement layer parameters and are generally taken at nondistressed areas for flexible pavement and at midpanel (nondistressed) locations for rigid pavements. However, the MEPDG recommends that FWD testing be conducted at distressed HMA areas as well to determine the “damaged” modulus.<sup>(2)</sup>

FWD testing is generally performed in the outermost lane (adjacent to the shoulder) for roadways with multiple lanes in one direction. The LTPP Program developed 11 test plans based on the experiment type (general or specific) and pavement type.<sup>(14)</sup> Testing layouts similar to test plans 4 and 5 of the LTPP data collection guidelines (see figure 19) are recommended. Note that flexible pavement testing includes two lanes of basin tests, one midlane, and one in the outer wheelpath, while rigid pavement testing is also conducted at midlane and in the outer wheelpath but also includes load transfer and corner testing in addition to basin tests. For two-lane

roadways, consideration can be given to staggering the test points by directional lane, assuming that the traffic levels are directionally similar. This can provide efficient testing coverage of the pavement project but does require additional traffic control planning and setup.

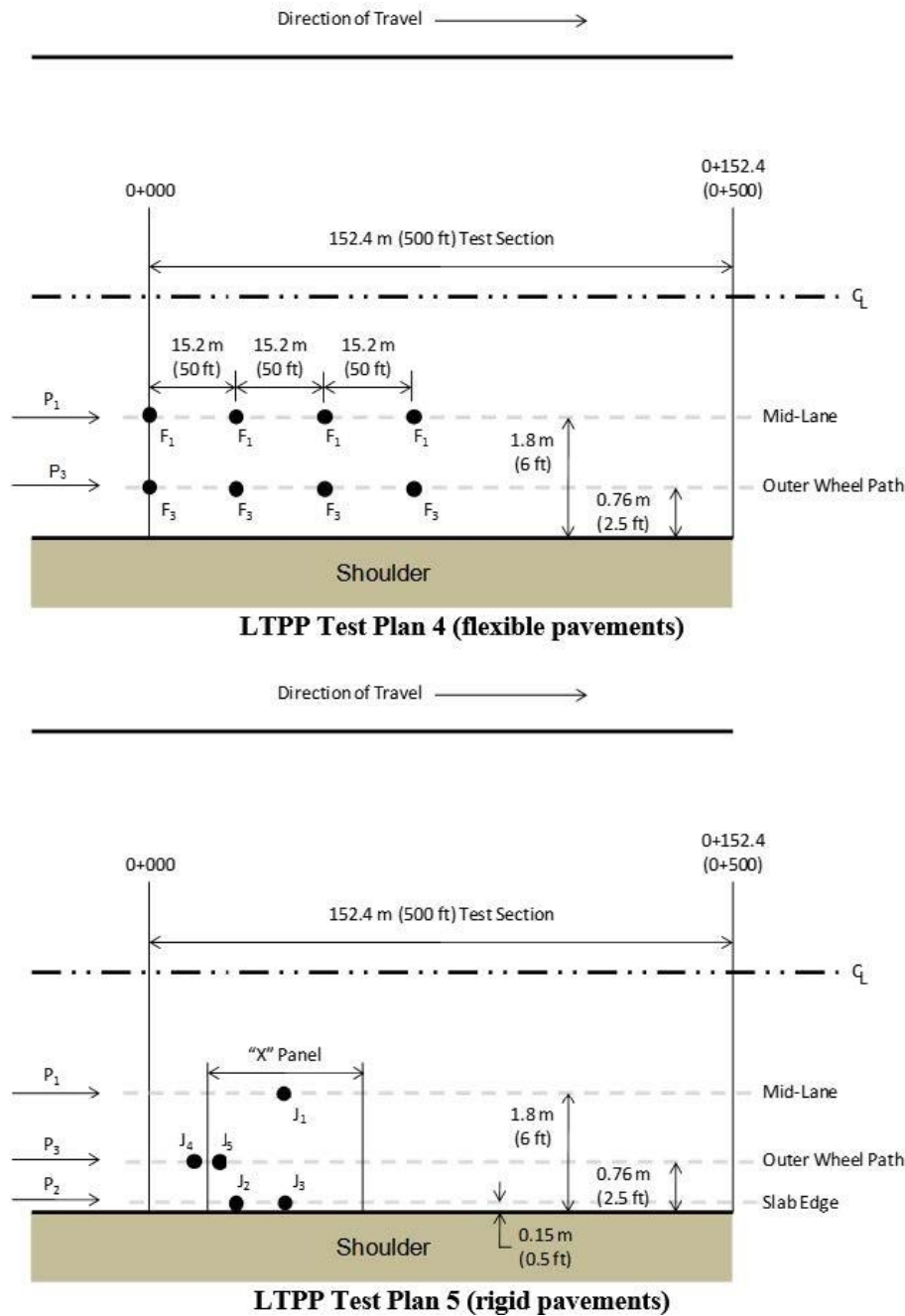

1 m = 3.28 ft.

$P_1, P_2, P_3$  = Pass through mid-lane, pavement edge, and outer wheel path, respectively.

$F_1, F_3$  = Measurement location along  $P_1$  and  $P_3$ , respectively.

$J_1, J_2, J_3, J_4, J_5$  = Measurement location along  $P_1$ —mid-panel, along  $P_2$ —corner, along  $P_2$ —mid-panel, along  $P_3$ —joint approach, and along  $P_3$ —joint leave, respectively.

CL = Center line.

**Figure 19. Diagram. Illustration of flexible and rigid pavement test plans.<sup>(14)</sup>**

AASHTO T 256 and ASTM D4695 indicate testing can be conducted either at midlane or in the outer wheelpath or both, and for rigid pavements suggests that a minimum of 25 percent of the joints associated with the basin tests should be tested.<sup>(17,18)</sup> Furthermore, for a detailed project analysis of a rigid pavement, AASHTO T 256 and ASTM D4695 recommend a closer basin testing interval and that all joints corresponding to basin tests should be tested.<sup>(17,18)</sup>

### **Testing Increments**

Testing increments are typically different for network-level and project-level evaluation. Network-level testing is commonly performed to obtain a general indication of the load-carrying capacity of the pavement structure as a means of identifying and prioritizing projects for maintenance and rehabilitation. Studies by several highway agencies suggest that testing intervals of between two and three points per 1.6 km (per mi) are adequate for network-level analyses.<sup>(19,20)</sup>

For project-level testing, much closer testing intervals are required to better characterize the pavement structure. The 11 testing plans developed for the LTPP Program testing show testing intervals of 7.6, 15.2, or 30.5 m (25, 50, or 100 ft) for flexible pavements and intervals of every 10 or 20 slabs for rigid pavements.<sup>(14)</sup> (Note that if a crack is present near midpanel, the slab is considered two effective slabs.) However, these intervals are for relatively short pavement test sections (generally 150 m (500 ft) or less). More universal guidance is offered by the MEPDG, AASHTO T 256, and ASTM D4695, which suggests basin test spacing of 30 to 150 m (100 to 500 ft) for project-level investigations.<sup>(1,17,18)</sup> For joint testing, the MEPDG recommends that testing should be performed across joints (or cracks) every 30 to 150 m (100 to 500 ft) and also suggests that depending on the length of the project and the availability of resources, the increment can be increased to every 305 m (1,000 ft).<sup>(1)</sup> In addition, it is also recommended that a minimum of 12 to 15 tests be conducted per uniform test section.<sup>(11,18)</sup>

### **Temperature Measurements**

Temperature measurements should be collected during FWD testing. Because HMA is a temperature-dependent material, the modulus obtained during backcalculation represents the material's temperature at the time of testing. Having accurate temperature data helps determine the correction factor to apply to the backcalculated HMA modulus to obtain a value at a standard temperature (typically 21 °C (70 °F)) for use in design.

FWD testing on PCC pavements must consider the temperature at the time the testing is conducted. Ideally, testing should be performed at a time (typically night or early morning hours) when the slab is in a neutral or flat condition (that is, the edges or center are not potentially lifted off the base). However, this may be impractical for an agency that must test many kilometers (miles) of pavement every day. In general, deflection testing on PCC pavements should be conducted when the ambient temperature is below 27 °C (80 °F). Although the backcalculation procedures for PCC pavements do not currently incorporate temperature corrections, temperature measurements are also useful in evaluating backcalculation results for PCC pavements, particularly in terms of whether the slabs are exhibiting any curling that may be affecting the results. In addition, knowledge of the temperature conditions at the time of testing assists in evaluating LTE data.



### *Air and Surface Temperature*

Air and pavement surface temperatures should be recorded at each test location, and most FWD equipment has temperature sensors and operating software that record the data automatically. Air and surface temperatures can be used in procedures to estimate the mean temperature of the pavement but direct measurement is generally preferred.<sup>(9)</sup> The daily average temperatures for the 5 days preceding testing should also be obtained, particularly if the air and surface temperatures will be used to predict the mean pavement temperature.

### *Temperature Gradients*

The LTPP Program testing includes measuring the temperature gradient within the pavement surface layer.<sup>(14)</sup> This is accomplished by drilling holes to varying depths and measuring the temperatures with thermometers. The LTPP Program uses up to five holes drilled to depths summarized in table 6. (Note that hole depths that extend into the unbound layer may be eliminated, and the deepest hole should be drilled 25.4 mm (1 inch) above the bottom of the bound layer.)

**Table 6. LTPP Program temperature measurement hole depths.<sup>(14)</sup>**

<b>Hole Number</b>	<b>Hole Depth (mm (inches))</b>
1	25.0 (1.0)
2	50.0 (2.0)
3	100.0 (4.0)
4	200.0 (8.0)
5	300.0 (12.0)

Holes are generally drilled at one end of the project section in the outer wheelpath, and temperature readings are obtained at the beginning and end of the testing, as well as at selected intervals. Although the LTPP Program recommends retrieving temperatures every 30 min, this may not be practical given the time restraints of many project site closures; temperature readings every 1 h are recommended as a more practical interval. A minimum of three temperature readings, roughly correlated with the beginning, middle, and end of testing, should be obtained for smaller projects with shorter testing times.

When direct measurement of the temperature gradient is performed, the air and surface temperatures should also be taken at the temperature holes. This allows correlation of the air and surface temperatures at each test location to the measured mean pavement temperature.

### **Joint/Crack Opening**

The LTPP Program recommends collecting joint (and crack) width measurements at a minimum of 25 percent of the joint (or crack) deflection testing locations; however, if time allows, measurement at all testing locations is preferred.<sup>(14)</sup> For joints, the sawcut width is measured, and for cracks, the width of the full-depth crack (not necessarily the surface width) is measured. Joint/crack measurements can be reviewed during the analysis of LTE. In general terms, a tight joint/crack should have higher LTEs.

## **Safety Guidelines**

Safety during FWD testing applies to the operation of the equipment and working in (or adjacent to) moving traffic. The FWD includes high-pressure hydraulics, electronics, and heavy moving parts that create many potential work hazards. Equipment manufacturers provide extensive documentation on the operation and maintenance of the testing equipment, and it is strongly recommended that operators become familiar with the documented materials and are well trained with the equipment.

Working around moving traffic can be a hazardous situation regardless of the work activity. Traffic control measures and work zone requirements must adhere to the guidelines of the governing agency.

## **Summary of FWD Testing Recommendations**

Table 7 provides an overall summary of the FWD testing recommendations described in the previous subsections. Recommendations include sensor configuration, load levels and drops, testing locations, testing increments, and temperature measurements.

**Table 7. Summary of deflection testing recommendations.**

<b>Testing Component</b>	<b>HMA Pavements Recommendation</b>	<b>PCC Pavements Recommendation</b>
Sensor configuration, mm (inches)	0, 203, 305, 457, 610, 914, 1,219, 1,524, –305 (0, 8, 12, 18, 24, 36, 48, 60, –12)	0, 203, 305, 457, 610, 914, 1,219, 1,524, –305 (0, 8, 12, 18, 24, 36, 48, 60, –12)
Load level, kN (lbf)	Seating, 26.7, 40.0, and 53.4 (6,000, 9,000, and 12,000)	Seating, 40.0 and 53.4 (9,000 and 12,000)
Number of drops	One for each load level	One for seating, 9,000- and 12,000-lbf (40- to 15.2-kN) load levels
Testing locations	<ul style="list-style-type: none"> <li>• Testing in outer traffic lane on multiple lane facilities</li> <li>• Possible directionally staggered testing on two-lane facilities</li> <li>• Midlane and outer wheelpath</li> </ul>	<ul style="list-style-type: none"> <li>• Testing in outer traffic lane on multiple lane facilities</li> <li>• Possible directionally staggered testing on two-lane facilities</li> <li>• Midlane, outer wheelpath, and transverse joint</li> </ul>
Testing increments, general	12 to 15 tests per uniform pavement section, at 30.5- to 152.4-m (100- to 500-ft) intervals	12 to 15 tests per uniform pavement section, at 30.5- to 152.4-m (100- to 500-ft) intervals
Testing increments, project level	25- to 50-ft (7.62- to 15.24-m) intervals	25- to 50-ft (7.62- to 15.24-m) intervals
Temperature measurements, air and surface	Measure at each test location	Measure at each test location
Temperature measurements, in pavement	Measure at 1-h intervals at depths of 25.0, 50.0, 100.0, 200.0 and 300.0 mm (1, 2, 4, 8, and 12 inches)	Measure at 1-h intervals at depths of 25.0, 50.0, 100.0, 200.0 and 300.0 mm (1, 2, 4, 8, and 12 inches)

## DATA CHECKS

### Types of Errors

The following data checks should be enabled in the FWD data collection software to flag certain conditions suggestive of errors or problems:<sup>(14)</sup>

- **Roll-off (i.e., deflection sensor does not return to near 0 within 60 ms of the trigger activation):** The roll-off error can occur when there is poor contact between the pavement surface and the deflection sensor or when the magnitude of the deflection approaches the resolution of the geophone.
- **Non-decreasing deflections (i.e., deflection measurements do not decrease with increasing distance from the load plate):** This error may occur if a transverse crack or

other discontinuity exists between two adjacent geophones or on very stiff PCC pavements if the deflection difference is less than the random error inherent to the deflection sensor. If neither condition exists, this error can typically occur owing to poor seating between the sensor and the pavement surface.

- **Overflow (i.e., measured deflections exceed the range of the deflection sensor):** In general, this error is only expected with extremely weak pavements or when testing at extremely high load levels. (See next section for a discussion on dealing with deflection errors.)
- **Load variation (the peak load for multiple drops at the same height varies by more than  $\pm (0.18 \text{ kN} + 0.02 \text{ kN} \times \text{applied load})$  ( $\pm (40.5\text{-lbf} + 0.02 \times \text{applied load})$ ):** This condition may occur on an extremely weak pavement if the FWD testing has damaged the pavement structure, when testing during a spring thaw or if the load plate is not properly seated on the pavement surface. (See next section for a discussion on dealing with load errors.)
- **Deflection variation (the load-normalized peak deflections from repeat drops varies by more than  $\pm (2 \mu\text{m} + 0.01\mu\text{m} \times \text{deflection})$  ( $\pm (0.079 \text{ mil} + 0.01 \times \text{measured deflection})$ ):** This error can occur for pavement structures that are unaffected by FWD testing (e.g., extremely weak pavements or the unbound layers of the pavement are saturated). In addition, it can be caused by poor seating of either the load plate or the deflection sensors, or possibly by vibration caused by heavy equipment (e.g., trucks traveling in an adjacent lane) in the vicinity of the FWD test. (See next subsection for discussion on dealing with deflection errors.)

### Addressing Deflection Errors

When deflection errors are encountered during FWD testing, the following steps are recommended to resolve the issue:<sup>(14)</sup>

1. Verify the condition of FWD by ensuring the deflection sensor(s) is seated securely to the sensor holder(s), all screws holding the sensor magnet and sensor holder are tight, and the holder springs and foam bushing are in good shape. If multiple sensors have errors, check all analog connections.
2. Verify the pavement condition by ensuring the sensor holder is not resting on a loose stone or crack.
3. Reject the original data and repeat the test without moving the FWD.
4. If the error persists and the FWD can be repositioned, move forward 0.6 m (2 ft) and retest. If the error still persists, accept the data and note that the error could not be resolved.
5. If the error persists and the FWD cannot be repositioned (e.g., load transfer test), accept the test and note that the error could not be resolved.

## Addressing Load Errors

If load errors are experienced, the following steps are recommended to resolve the issue:<sup>(14)</sup>

1. Reject the data and retest without repositioning the FWD.
2. If the error persists, check all analog connections to ensure the weight/height targets are tight, raise the load plate and ensure the swivel moves easily, and ensure the rubber sheet and pavement surface beneath the load plate are clear of debris.
3. Reject the data and repeat the test without repositioning the FWD.
4. If the error persists and the FWD can be repositioned, move forward 0.6 m (2 ft) and retest. If the error still persists, accept the data and note that the error could not be resolved.
5. If error persists and the FWD cannot be repositioned (e.g., load transfer test), accept the test and note that the error could not be resolved.

## ADDITIONAL SOURCES FOR DEFLECTION TESTING GUIDELINES

In addition to the LTPP Program (Federal Highway Administration (FHWA)), AASHTO, and ASTM International documents that are cited as primary source documents in this chapter, a number of additional sources provide guidance on FWD testing and data collection. These include documents prepared by NCHRP, the Department of Defense, the Federal Aviation Administration, and the European Commission Directorate General Transport. (See references 4, 21, 22, and 11.) In addition, many highway agencies have developed their own custom FWD testing procedures and protocols.

## FWD CALIBRATION

Routine FWD calibration is a vital component to ensure accurate loading and deflection measurements. As outlined in AASHTO R32-09, FWD calibration should include the following:<sup>(23)</sup>

- **Annual calibration of the load cell and deflection sensors using an independently calibrated reference device (referred to as reference calibration):** Deflection sensors are also compared with each other (referred to as relative calibration). Annual calibration should also be conducted as soon as possible after load cell or deflection sensor replacement. Annual calibration is performed by a certified technician.
- **Monthly relative calibration of the deflection sensors:** Monthly deflection sensor calibration is conducted using a relative calibration stand supplied by the FWD manufacturer and is different than the relative calibration conducted during annual calibration. Relative calibration should also be conducted immediately after replacement of a deflection sensor. Relative calibration does not require a certified technician.

## **SUMMARY**

This chapter presents an overview of deflection testing. Pavement deflection testing is recognized as a reliable, quick, and inexpensive method for determining the structural condition of existing pavements. Specifically, deflection measurements can be used for backcalculating the elastic moduli of the pavement structural layers and for estimating the load-carrying capacity of both HMA and PCC pavements. In addition, in PCC pavements, loss of support at slab corners can be identified and evaluation of the joint or crack load transfer can be performed using deflection testing.

Pavement deflections represent an overall system response of the pavement structure and subgrade soil to an applied load. The major factors that affect pavement deflections can be grouped into categories of pavement structure (type and thickness), pavement loading (load magnitude and type of loading), and climate (temperature and seasonal effects). Consideration of these factors should be an integral part of the deflection testing process so that the resultant deflection data are meaningful and representative of actual conditions.

Overall recommendations for setting up a FWD testing program are presented, including sensor configuration, loading levels and drop sequencing, testing locations and intervals, and temperature measurements. In addition, the types of errors commonly encountered during FWD testing are briefly described, along with ways of addressing these items during the testing program.

## CHAPTER 3. GENERAL BACKCALCULATION GUIDELINES

Because the most common use of deflection data is in the backcalculation of the fundamental engineering parameters of the paving layers, this chapter has been prepared to provide general guidance on performing backcalculation. The guidelines are intended to assist the pavement engineer in conducting the backcalculation process, evaluating the results, and ensuring that those results are reasonable; however, they should be used only as general guidance because considerable engineering judgment and expertise is still required.

In addition to the guidelines on pavement backcalculation, this chapter describes the results of studies that have verified backcalculated results with instrumented pavement sections and also presents an example illustrating the interpretation of results from a backcalculation program.

### BACKCALCULATION VERSUS FORWARDCALCULATION

In the backcalculation process, pavement deflections are determined using layer elastic theory, layer thickness, and assumed layer moduli (e.g., HMA layer, unbound base layer, and subgrade). An iterative approach is used to vary layer moduli until the calculated deflection basin matches the FWD-measured deflection basin. A solution is found when the difference between the measured and calculated deflection basin is minimized (discussed in the following sections).

In forwardcalculation, load and deflection data are entered into closed-form equations for estimating layer moduli. Forwardcalculation can be used to estimate layer moduli for the subgrade and bound surface layers, while intermediate layer (e.g., unbound base) moduli are estimated using modular ratios.<sup>(24)</sup>

The primary difference between backcalculation and forwardcalculation is that the former uses specific equations, while the latter uses an iterative procedure in estimating layer moduli.

### BACKCALCULATION GUIDELINES

Over the years, researchers and practitioners have developed numerous approaches to backcalculate pavement layer and subgrade moduli, as well as numerous software programs to perform the calculations. Table 8 summarizes available software programs that can be used for backcalculation of pavement deflection data that the research team was able to identify during the conduct of this research study.

**Table 8. Summary of available backcalculation programs.**

<b>Program Name</b>	<b>Public Domain</b>	<b>Pavement Type</b>	<b>Maximum Number of Layers</b>	<b>Convergence Scheme</b>	<b>Error Weighting Function</b>
BAKFAA	Yes	Flexible/rigid	Five	Sum of squares of absolute error	Yes
BISDEF©	No	Flexible	Number of deflections; best for three unknowns	Sum of squares of absolute error	Yes
BOUSDEF 2.0	No	Flexible	At least four	Sum of percent errors	Varies
CHEVDEF	Yes	Flexible	Number of deflections; best for three unknowns	Sum of squares of absolute error	Yes
COMDEF	No	Composite	Three	Various	No
DBCONPAS	No	Rigid	Two	N/A	N/A
DIPLOBACK	No	Composite	Three	Closed form solution	N/A
ELMOD®/ ELCON 5	No	Flexible/rigid	Four (exclusive of rigid layer)	Relative error of five sensors	No
ELSDEF	No	Flexible	Number of deflections; best for three unknowns	Sum of squares of absolute error	Yes
EMOD	No	Flexible	Three	Sum of relative squared error	No
EVERCALC©	Yes	Flexible	Three (exclusive of rigid layer)	Sum of absolute error	No
FPEDD1	No	Flexible	Three- or four-layer model	Relative deflection error	No
ISSEM4	No	Flexible	Four	Relative deflection error	No
MICHBACK©	Yes	Flexible/ composite	Three + rigid layer	Least squares	Yes
MODTAG©	Yes	Flexible	Two to 15 layers; maximum of five unknown layers	Relative deflection error at sensors	No
MODULUS 6.0	Yes	Flexible	Four plus rigid layer	Sum of relative squared error	Yes
PADAL 2	No	Flexible	Four plus rigid layer	Sum of relative squared error	Yes
PCASE 2.08	Yes	Rigid/flexible/ composite	5	Sum of squares of absolute error	Yes
RPEDD1	No	Rigid	Three- or four-layer model	Relative deflection error	No
WESDEF	Yes	Flexible	Four + rigid layer	Sum of squares of absolute error	Yes

N/A = Not applicable.



## Inputs Needed for Backcalculation Analysis

The following inputs are needed to perform a backcalculation analysis:

- FWD testing configuration and results (load plate diameter, sensor locations, load level, test locations, and resulting deflections).
- Pavement temperature at the time of FWD testing.
- Pavement structure (layer types (e.g., HMA, PCC, base/subbase material), layer thicknesses, Poisson's ratio for each layer (often assumed), material density (often assumed), and subgrade).
- Modulus values, including seed or initial moduli, and modulus range.

## Backcalculation Pavement Model

A number of different factors must be considered in establishing a model of the pavement section for backcalculation, as described in the following sections.

### *Number of Layers*

Ideally, no more than three (preferable) or four layers with unknown moduli should be used in the backcalculation process. If the backcalculation results produce unrealistic weak base moduli, it may be advantageous to eliminate the base layer and evaluate the pavement structure as a two-layer system. In this case, the lower base moduli may indicate contamination from the underlying subgrade, resulting in weaker base moduli owing to the presence of finer material.<sup>(25)</sup> If unrealistic results persist, then the analysis should consider the presence of a stiff layer.

When a pavement structure consists of a stiff layer between two weak layers, the backcalculation process may produce unrealistic moduli.<sup>(25)</sup> If this is the case, other means (e.g., laboratory testing) may be required for determining layer moduli.

### *Thickness of Layers*

The following subsections provide guidelines for setting the layer thickness for each pavement layer.

#### *HMA*

It can be difficult to obtain reasonably backcalculated moduli for bituminous surface layers less than 75 mm (3 inches) thick. If the total thickness of the bituminous layer is less than 75 mm (3 inches), the modulus of the bituminous layer should be fixed (see table 9 for guidance) to allow backcalculation of the base and subgrade moduli.

**Table 9. HMA moduli versus temperature.<sup>(26)</sup>**

<b>Temperature (°C (°F))</b>	<b>HMA Modulus (MPa (lbf/inch<sup>2</sup>))</b>
-7 (20)	17,852 (2,589,138)
-1 (30)	15,066 (2,185,115)
4 (40)	11,881 (1,723,141)
10 (50)	8,754 (1,269,682)
16 (60)	6,027 (874,172)
21 (70)	3,878 (562,375)
27 (80)	2,331 (338,052)
32 (90)	1,309 (189,875)
38 (100)	687 (99,651)

Theoretically, backcalculation of each individual bituminous layer is possible, but this is generally not advised because of the complexity of evaluating more than three or four pavement layers. Ideally, all bituminous layers (seal coats, chip seals, and HMA) should be combined into a single layer unless there is evidence of an HMA layer exhibiting a unique distress.<sup>(27)</sup> In general, the presence of stripping or debonding of HMA layers reduces the backcalculated HMA moduli. In these cases, coring may be required to confirm the presence of stripping or debonding.

#### *PCC*

There are no thickness limitations associated with the backcalculation of modulus values for concrete pavements.

#### *Unstabilized Base/Subbase Course*

The presence of a thin base course beneath a thick HMA or PCC surface layer often results in low base moduli. This can occur because of the insignificant effects of a thin base beneath a very stiff thick layer, or it may be that the base modulus is low due to the stress sensitivity of granular materials.<sup>(25)</sup> In this case, it is advisable to combine the base with the subgrade and conduct the backcalculation as a two-layer system. If consideration of the base layer is desired, including a stiff layer in the backcalculation process may improve the base/subbase layers modulus estimate.

#### *Subgrade*

If an unusually high subgrade modulus is determined from the backcalculation results, the site should be investigated for the possible presence of a shallow bedrock/stiff layer or a high water table.

#### *Initial and Moduli Ranges*

The following subsections provide guidelines for the typical range of layer moduli that should be considered in establishing a pavement section model for backcalculation.

## HMA

Generally, new HMA is observed to have backcalculated moduli ranging from 2,000 to 4,000 MPa (300,000 to 600,000 lbf/inch<sup>2</sup>), while a fatigue-cracked HMA is often observed to have backcalculated moduli between 700 and 1,400 MPa (100,000 to 200,000 lbf/inch<sup>2</sup>) at about 25 °C (77 °F). In some cases, areas of severe alligator cracking can result in backcalculated HMA layer moduli that significantly exceed the expected moduli values. If the HMA layer is known to have severe alligator cracking and results in high backcalculated layer moduli, it is recommended that either the HMA layer moduli be fixed at 700 to 1,400 MPa (100,000 to 200,000 lbf/inch<sup>2</sup>) or the testing location not be used in the backcalculation analysis. However, the presence of severe alligator cracking represents an area of structural deficiency and may require repair before overlay or at least should be taken into account during the overlay thickness design process.

If an HMA modulus range is required, an initial estimate of the HMA modulus should be made and then the range can be selected as 0.25 to five times that value.<sup>(27)</sup> For example, if the initial HMA modulus estimate is 2,800 MPa (400,000 lbf/inch<sup>2</sup>), then a range of 700 to 14,000 MPa (100,000 to 2 million lbf/inch<sup>2</sup>) is selected.

## PCC

The modulus of an uncracked concrete pavement typically ranges from about 10,000 to 70,000 MPa (1.5 million to 10 million lbf/inch<sup>2</sup>).<sup>(28)</sup> An initial modulus ranging from 28,000 to 40,000 MPa (4 million to 6 million lbf/inch<sup>2</sup>) is typical.

## Unstabilized Bases and Subbases

Initial modulus and moduli ranges are listed in Table 10 for a variety of unstabilized base and subbase materials.

**Table 10. Typical layer moduli for unstabilized materials.**<sup>(27-29)</sup>

<b>Material Type</b>	<b>Initial Modulus (MPa (lbf/inch<sup>2</sup>))</b>	<b>Moduli Range (MPa (lbf/inch<sup>2</sup>))</b>
Uncrushed gravel	140–200 (20,000–30,000)	50–750 (7,000–110,000)
Crushed stone or gravel	200–345 (30,000–50,000)	70–7,000 (10,000–150,000)
Sand	100–140 (15,000–20,000)	35–550 (5,000–80,000)
Soil-aggregate mixture (predominantly fine-grained)	100–140 (15,000–20,000)	50–700 (7,000–100,000)
Soil-aggregate mixture (predominantly coarse-grained)	140–200 (20,000–30,000)	60–800 (9,000–120,000)

Note: Data in this table were taken from references 27–29.

## Stabilized Bases and Subbases

Initial modulus and moduli ranges are presented in table 11 for a variety of stabilized base and subbase materials.

**Table 11. Typical layer moduli for stabilized materials.**<sup>(28,29)</sup>

<b>Material Type</b>	<b>Initial Modulus (MPa (lbf/inch<sup>2</sup>))</b>	<b>Moduli Range (MPa (lbf/inch<sup>2</sup>))</b>
Asphalt treated	700–1,400 (100,000–200,000)	700–25,000 (100,000–3.5 million)
Sand asphalt	700–1,400 (100,000–200,000)	700–25,000 (100,000–3.5 million)
Fractured PCC	3,000–3,500 (400,000–500,000)	700–20,000 (100,000–3 million)
Cement aggregate mixture	3,000–3,500 (400,000–500,000)	2,000–20,000 (300,000–3 million)
Lean concrete	4,000–5,000 (600,000–700,000)	4,500–45,000 (650,000–6.5 million)
Cement treated	1,400–2,000 (200,000–300,000)	700–3,000 (100,000–400,000)
Lime stabilized	200–300 (30,000–40,000)	35–1,500 (5,000–200,000)
Soil cement	2,000–3,500 (300,000–500,000)	1,000–7,000 (150,000–1 million)

Note: Data in this table were taken from references 28 and 29.

### *Subgrade*

Table 12 includes suggested values for subgrade moduli by soil type and climate condition.

**Table 12. Typical moduli values of various subgrade materials for climate conditions.**<sup>(30)</sup>

<b>Material</b>	<b>Dry (MPa (lbf/inch<sup>2</sup>))</b>	<b>Wet-No Freeze (MPa (lbf/inch<sup>2</sup>))</b>	<b>Wet-Freeze Unfrozen (MPa (lbf/inch<sup>2</sup>))</b>	<b>Wet-Freeze Frozen (MPa (lbf/inch<sup>2</sup>))</b>
Clay	103 (15,000)	41 (6,000)	41 (6,000)	345 (50,000)
Silt	103 (15,000)	41 (6,000)	34 (5,000)	345 (50,000)
Silty or clayey sand	138 (20,000)	69 (10,000)	34 (5,000)	345 (50,000)
Sand	172 (25,000)	172 (25,000)	172 (25,000)	345 (50,000)
Silty or clayey gravel	276 (40,000)	207 (30,000)	138 (20,000)	345 (50,000)
Gravel	345 (50,000)	345 (50,000)	276 (40,000)	345 (50,000)

### *Poisson's Ratio*

Table 13 provides recommendations for Poisson's ratio for various paving and subgrade materials.

**Table 13. Typical Poisson's ratio values.**<sup>(31)</sup>

<b>Material Type</b>	<b>Poisson's Ratio</b>
HMA	0.35
PCC	0.15–0.20
Stabilized base or subbase	0.25–0.35
Unstabilized base or subbase	0.35
Cohesive (fine grain) subgrade soils	0.45
Cohesion less (coarse grain) subgrade soils	0.35–0.40
Stiff layer	0.35 or less

### Depth to Bedrock/Stiff Layer or Water Table

The presence of shallow bedrock, a stiff clay layer, or high groundwater table can have a significant effect on backcalculated layer moduli. Assuming the subgrade layer to be a semi-infinite halfspace, while in reality the subgrade layer is only a few meters (feet) thick, causes the backcalculated moduli for the upper pavement layers to be incorrect. Generally, when the stiff layer is deeper than about 12 m (39 ft), its presence has little or no influence on the backcalculated moduli. The depth to the stiff layer can be evaluated by using a relationship between the deflection,  $\delta_z$ , and  $1/r$ , where  $r$  is the corresponding offset of the measured surface deflection (see figure 20).<sup>(32)</sup>

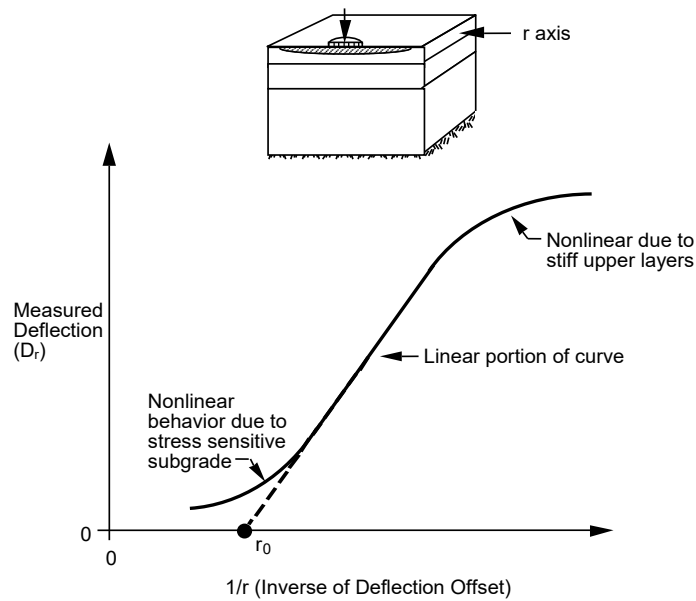

©Washington State Department of Transportation

**Figure 20. Graph. Inverse of deflection offset versus measured deflection.**<sup>(31)</sup>

The determination of the depth to the stiff layer using the offset of inverse deflection uses the following regression equations (see figure 21 through figure 24) for various HMA layer thicknesses:<sup>(32)</sup>

$$\frac{1}{B} = 0.0362 - 0.3242(r_0) + 10.2717(r_0^3) - 0.0037(BCI)$$

**Figure 21. Equation. Determination of depth to stiff layer, HMA less than 50 mm (2 inches) thick ( $R^2 = 0.98$ ).**

$$\frac{1}{B} = 0.0065 - 0.1652(r_0) + 5.4290(r_0^2) + 11.0026(r_0^3) - 0.0004(BDI)$$

**Figure 22. Equation. Determination of depth to stiff layer, HMA 50 to 100 mm (2 to 4 inches) thick ( $R^2 = 0.98$ ).**

$$\frac{1}{B} = 0.0413 - 0.9929(r_0) - 0.0012((SCI) + 0.0063(BDI) - 0.0778(BCI))$$

**Figure 23. Equation. Determination of depth to stiff layer, HMA 100 to 150 mm (4 to 6 inches) thick ( $R^2 = 0.94$ ).**

$$\frac{1}{B} = 0.0409 - 0.5669(r_0) + 3.0137(r_0^2) + 0.0033(BDI) - 0.0665 \log(BCI)$$

**Figure 24. Equation. Determination of depth to the stiff layer, HMA greater than 150 mm (6 inches) thick ( $R^2 = 0.97$ ).**

Where:

$B$  = Depth to rigid layer, measured from pavement surface (ft).

$r_0$  =  $1/r$  intercept (extrapolate steepest section of  $D_r$  versus  $1/r$  plot) in units of  $1/\text{ft}$ .

$BCI = D_{24} - D_{36}$  BCI (i.e., MLI) (mil).

$BDI = D_{12} - D_{24}$  BDI (i.e., LLI) (mil).

$SCI = D_0 - D_{12}$  SCI (i.e., BLI) (mil).

*Example of Calculating Depth to Stiff Layer<sup>(31)</sup>*

Typical deflection data for an HMA pavement section with an asphalt layer thickness of 194 mm (7.65 inches) are shown in table 14. In addition, soil borings indicate a stiff layer may be present at 5.0 m (198 inches). The corresponding values of  $1/r$  (expressed in terms of  $1/\text{ft}$ ) are shown in table 15 for each sensor offset.

**Table 14. Typical and normalized deflection.<sup>(31)</sup>**

Load Level	$D_0$ ( $\mu\text{m}$ (mil))	$D_{200}$ (8 inches) ( $\mu\text{m}$ (mil))	$D_{300}$ (12 inches) ( $\mu\text{m}$ (mil))	$D_{450}$ (18 inches) ( $\mu\text{m}$ (mil))	$D_{600}$ (24 inches) ( $\mu\text{m}$ (mil))	$D_{900}$ (36 inches) ( $\mu\text{m}$ (mil))	$D_{1500}$ (60 inches) ( $\mu\text{m}$ (mil))
29.1 kN (6,534 lbf)	83 (3.28)	68 (2.69)	59 (2.33)	48 (1.88)	40 (1.56)	28 (1.09)	17 (0.68)
42.3 kN (9,512 lbf)	129 (5.07)	110 (4.32)	93 (3.67)	76 (2.99)	61 (2.40)	43 (1.69)	26 (1.01)
Normalized to 40 kN (9,000 lbf)	121 (4.76)	103 (4.04)	87 (3.44)	71 (2.80)	57 (2.26)	40 (1.59)	24 (0.95)

**Table 15. Values for 1/r values (at 40-kN (9,000-lbf) load level).**

$D_r$ (mil)	$R$ (inch)	$1/r$ (1/ft)
4.76	0	N/A
4.04	8	1.50
3.44	12	1.00
2.80	18	0.67
2.26	24	0.50
1.59	36	0.33
0.95	60	0.20

N/A = Not applicable.

With this information, the equation in figure 24, repeated here as figure 25, (for HMA thickness > 150 mm (6 inches)) is used to calculate  $B$ .

$$\frac{1}{B} = 0.0409 - 0.5669(r_0) + 3.0137(r_0^2) + 0.0033(BDI) - 0.0665 \log(BCI)$$

**Figure 25. Equation. Determination of depth to the stiff layer, HMA greater than 150 mm (6 inches) thick ( $R^2 = 0.97$ ).**

Where:

$r_0 = 1/r$  intercept (refer to figure 26)  $\cong 0$  (steepest part of deflection basin for deflections at 36 and 60 inches).

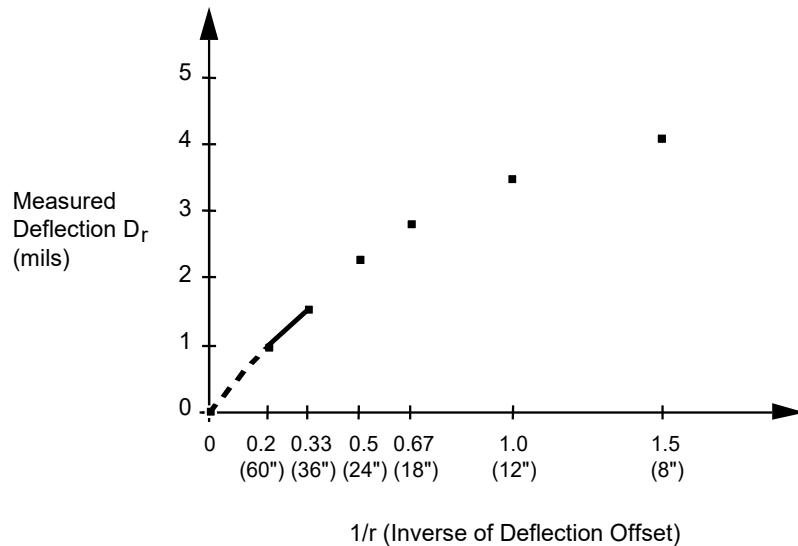

©Washington State Department of Transportation  
 1 mil = 0.0254 mm.  
 1 inch = 25.4 mm.

**Figure 26. Graph. Measured deflection versus  $1/r$ .<sup>(31)</sup>**

Therefore, the depth to the stiff layer in this case is calculated as shown in figure 27.

$$\frac{1}{B} = 0.0409 + 0.5669(0) + 3.0137(0^2) + 0.003(1.18) - 0.0665(0.67) = 0.0564$$

$$B = 17.7 \text{ ft}(5.4 \text{ m})$$

**Figure 27. Equation. Sample computation of depth to the stiff layer with HMA greater than 150 mm (6 inches) thick ( $R^2 = 0.97$ ).**

Recalling that the soil boring indicated the potential of a stiff layer at 5.0 m (16.5 ft), the estimate for the depth to the stiff layer using the inverse of deflection offset agrees reasonably well.

An alternative way to determine the depth to the stiff layer is to use the free vibration response from FWD deflection sensor measurements and one-dimensional wave propagation theory.<sup>(33)</sup>

Chatti, Ji, and Harichandran modified Roesset's equations to account for different conditions, as shown in figure 28.<sup>(34)</sup>

$$D_b = \frac{V_s * T_d}{1.35} \quad (a)$$

$$D_b = \frac{V_s * T_d}{(\pi - 2.24 * u)} \quad (b)$$

**Figure 28. Equation. Determination of depth to the stiff layer using modified Roesset's equations.**

Where:

$V_s$  = Shear-wave velocity of subgrade =  $[(E_{sg}/(2(1 - u^2)))/\rho]^{0.5}$ .

$E_{sg}$  = Modulus of the subgrade.

$\rho$  = Unit weight of the subgrade.

$u$  = Poisson's ratio of subgrade.

$T_d$  = Natural period of free vibration (see figure 29).



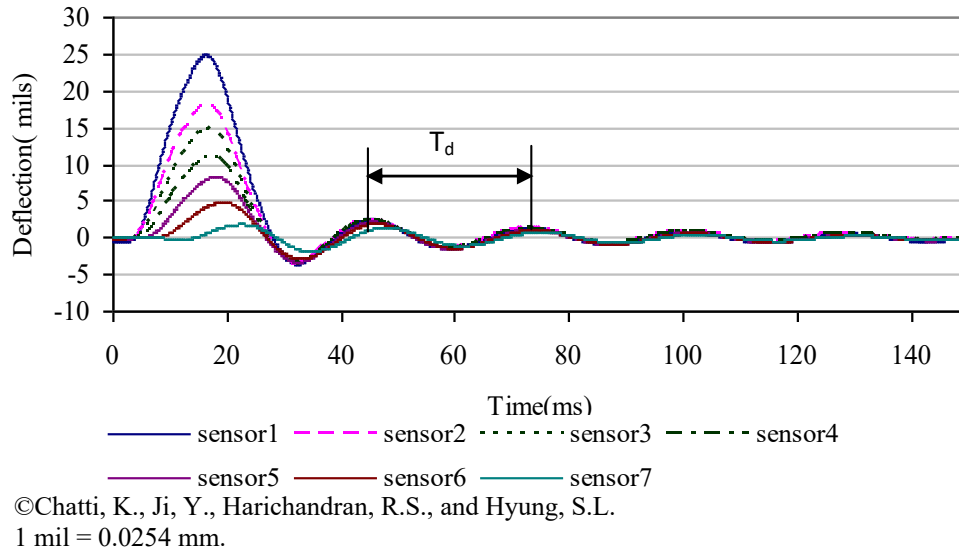

**Figure 29. Graph. Illustration of natural period,  $T_d$ , from sensor deflection time histories.<sup>(34)</sup>**

In the backcalculation process, the stiffness of a stiff layer is often fixed at modulus values ranging from 700 to 6,900 MPa (100,000 to 1 million lbf/inch<sup>2</sup>). When a stiff layer is included, the subgrade must have a specified thickness, and the bedrock/stiff layer is assumed to have an indefinite depth. If a stiff layer is believed to exist, but exact depth data are not available, the depth in the backcalculation process should be varied (e.g., depths of 6, 9, or 15 m (20, 30, or 50 ft)) to determine whether reasonable results can be obtained. Ideally, the depth to the stiff layer should be verified by subsurface borings.

If the layer is due to the presence of a water table (or saturated soil), then a modulus value of about 345 MPa (50,000 lbf/inch<sup>2</sup>) should be used. If rock or stiff soils (e.g., glacial till) are present, then a modulus value of about 6,900 MPa (1 million lbf/inch<sup>2</sup>) may be more appropriate.

### *PCC Pavement Interface Conditions*

The ability to account for the interface condition between a PCC slab and the underlying base/subbase layer can have a significant effect on the backcalculated results.<sup>(35)</sup> This was demonstrated on an evaluation of two LTPP Program General Pavement Studies rigid pavement sections: section 105004, consisting of a 225-mm (8.8-inch) continuously reinforced concrete pavement (CRCP) over a 100-mm (4-inch) cement-aggregate mixture, and section 204052, consisting of a 225-mm (8.8-inch) jointed plain concrete pavement (JPCP) over a 100-mm (4-inch) lean concrete base. Backcalculation scenarios include the following:

- **No base:** Base layer was excluded from the analysis.
- **No bond:** Base layer is in full slip with the PCC layer.
- **Full bond:** Base layer is in full friction with the PCC layer.

The results of the analysis, shown in table 16, indicate that the PCC layer moduli for the no base scenario are unreasonably high for both LTPP Program sections. The full bond assumption

produces more reasonable results for section 204052, whereas the no bond scenario provides more reasonable results for section 105004.

**Table 16. Effects of interface condition.**<sup>(35)</sup>

<b>LTPP Program Section</b>	<b>No Base <math>E_{PCC}</math> (MPa (lbf/inch<sup>2</sup>))</b>	<b>No Bond <math>E_{PCC}</math> (MPa (lbf/inch<sup>2</sup>))</b>	<b>No Bond <math>E_{Base}</math> (MPa (lbf/inch<sup>2</sup>))</b>	<b>Full Bond <math>E_{PCC}</math> (MPa (lbf/inch<sup>2</sup>))</b>	<b>Full Bond <math>E_{Base}</math> (MPa (lbf/inch<sup>2</sup>))</b>
105004	31,034 (4,501,101)	30,501 (4,423,796)	6,100 (884,730)	20,283 (2,941,800)	4,056 (588,273)
204052	8,203 (1,189,745)	79,569 (11,540,508)	19,892 (2,885,090)	49,871 (7,233,177)	12,468 (1,808,330)

$E_{PCC}$  = PCC layer moduli.

$E_{Base}$  = Base layer moduli.

### *Stabilized Base Under PCC Pavements*

It is difficult to precisely determine the layer modulus of a stabilized base beneath a concrete slab from surface deflection data. Given that the bending stiffness of multiple pavement layers (plates) can be represented by an equivalent plate with an effective thickness ( $h_e$ ) and modulus ( $E_e$ ), it is not possible to resolve the backcalculated effective modulus into component moduli without having additional information on the interface bonding condition and the relative stiffness of the slab and stabilized base (also known as the modular ratio). However, these can be estimated and used iteratively to obtain reasonable estimates of the slab and base modulus values. The two equations in figure 30 can be used to determine the slab modulus value for the unbonded and bonded conditions; the stiffness of the stabilized base,  $E_2$ , can be found by multiplying the stiffness of the slab by the modular ratio,  $\beta$ .<sup>(35)</sup>

$$E_1 = \frac{h_1^3}{h_1^3 + \beta h_2^3} \cdot E_e \quad (a)$$

$$E_1 = \frac{h_1^3}{h_1^3 + \beta h_2^3 + 12h_1 \left(x - \frac{h_1}{2}\right)^2 + 12\beta h_2 \left(h_1 - x + \frac{h_2}{2}\right)^2} E_e \quad (b)$$

where:

$$x = \frac{\frac{h_1^2}{2} + h_2 \beta \left(h_1 + \frac{h_2}{2}\right)}{h_1 + \beta h_2}$$

and:

$$\beta = \frac{E_2}{E_1}$$

**Figure 30. Equation. Determination of slab modulus values for (a) unbonded and (b) bonded conditions.**

Where:

$E_1$  = Modulus of upper plate, i.e., the PCC layer (MPa (lbf/inch<sup>2</sup>)).

$E_2$  = Modulus of lower plate, i.e., the base layer (MPa (lbf/inch<sup>2</sup>)).

$h_1$  = Thickness of upper plate, i.e., the PCC slab (mm (inches)).

$h_2$  = Thickness of lower plate, i.e., the base layer (mm (inches)).

$\beta$  = Modular ratio (see table 17 for selection).

**Table 17. Typical modular ratios ( $\beta$ ).<sup>(28)</sup>**

Base Type	$\beta$
HMA, dense graded	0.1000
Asphalt-treated base	0.0200
Lime-treated soil	0.0100
Cement aggregate mixture	0.2000
Lean concrete	0.5000
Econcrete	0.2500
Cement-treated soil	0.0200
Crushed rock	0.0070
Gravel, uncrushed	0.0050
Gravel, crushed	0.0060
Crushed stone	0.0070
Sand	0.0040
Soil-aggregate mixture (fine grained)	0.0025
Soil-aggregate mixture (coarse grained)	0.0040
Soil cement	0.1000

## **Modeling and Response Issues**

The pavement responses to loading can be modeled and interpreted in different ways as part of the backcalculation process. Some of these issues, and how they are often addressed, are described in the following subsections.

### *Static Versus Dynamic Response*

The difference between static response and dynamic response can be defined in terms of the internal forces involved. In a static analysis, only elastic forces are considered, and it is assumed that the peak deflection at each sensor occurs at the same time as the peak load. In actuality, viscous and inertial forces are at work in the pavement system, and there is a significant time lag between the peak load and the peak deflection for each sensor. A dynamic analysis tries to capture these time lag effects.

Many engineers argue that backcalculation is an exercise that determines pavement parameters, and not properties, to use within a given mechanistic framework. Therefore, it is acceptable to use static analysis and to backcalculate parameters that are compatible with the current mechanistic-empirical design framework grounded in static and not dynamic analysis. However, dynamic analysis advocates maintain that it takes advantage of more information provided by the test, which allows backcalculating more parameters such as layer thicknesses or the modulus versus frequency curve of the HMA layer. (See references 34 and 36–38.) Also, in certain cases, such as the existence of a stiff layer or water table at shallow depth, the effect of dynamics of pavement response may become more important.

### *Linear Versus Nonlinear Behavior*

When pavement structures are thin enough or the applied loads and corresponding stresses are high enough, fine-grained subgrade materials often exhibit stress-softening, nonlinear behavior (i.e., the subgrade material response increases at a higher rate than the load or stress increases). This means that the subgrade modulus changes with depth and with radial distance from the load. If the modeling approach assumes linear behavior, then only a single modulus value can be assigned to the subgrade, typically an averaged value that matches the measured deflections. For fine-grained materials, the backcalculated subgrade modulus is commonly higher than the laboratory-based measurement by a factor of two to three.

On the other hand, granular (cohesionless) materials used in bases and subbases are stress dependent in a different way, in that their modulus increases with increasing confinement. Similar to the subgrade modulus, this leads to a base/subbase modulus that varies with depth and radial distance from the load, and any linear backcalculation exercise can only lead to an averaged modulus value. The combination of the above phenomena often leads to a base modulus lower than the subgrade modulus even through the base material is of higher quality than the subgrade. Although one way of addressing this problem is to introduce an artificial layer, a more direct way of addressing the problem is to treat the subgrade as a nonlinear elastic material with stress-dependent modulus as shown in figure 31.<sup>(39)</sup>

$$E = C \left( \frac{\sigma_1}{p} \right)^n$$

**Figure 31. Equation. Stress-dependent modulus determination.**

Where:

$E$  = Modulus value (MPa (lbf/inch<sup>2</sup>)).

$C$  = Positive constant.

$n$  = Negative constant.

$p$  = Reference stress (atmospheric pressure of 0.1 MPa (14.5 lbf/inch<sup>2</sup>)).

Ullidtz argues that the effect of the positive non-linearity in granular base/subbase layers is less important to the backcalculation results.<sup>(39)</sup>

Although finite element modeling (FEM) can be used to evaluate the variation of modulus with depth and radial distance, models based on layered elastic theory can also handle nonlinear behavior (e.g., NELAPAVE and KENPAVE). For example, Ullidtz combines the method of equivalent thickness with a stress-dependent subgrade modulus (see figure 31 equation) to handle material nonlinearity and reports that this approach is superior to FEM.<sup>(39)</sup>

A number of backcalculation programs, such as BOUSDEF, EVERCALC®, FPEDD1, MODTAG®, and RPEDD1, include a nonlinear analysis component. Others, such as ELMOD®/ELCON, EMOD, ISSEM4, and PADAL, incorporate a nonlinear analysis for the subgrade only.

### **Temperature and Moisture Effects**

Temperature and moisture conditions in the pavement vary over time, both daily and seasonally. A pavement is generally stiffer (stronger) during the winter months because of the frozen state of the underlying materials and is typically at its weakest during the spring thaw period when the foundation materials are saturated.

Several State transportation departments have conducted FWD testing on multiple locations over consecutive seasons to determine the seasonal variation in the unbound layer moduli.<sup>(40)</sup> Based on the results of the studies, these agencies have developed a range of seasonal factors (see table 18) for adjusting layer moduli for use in a HMA overlay design procedure. In addition, the Enhanced Integrated Climatic Model (EICM), which is incorporated in the MEPDG, provides an analytical tool for predicting temperature, resilient modulus adjustment factors, pore water pressure, water content, frost and thaw depths, frost heave, and drainage performance for a given pavement.<sup>(1)</sup>

**Table 18. Seasonal moduli adjustment factors for unbound materials.**<sup>(40,41)</sup>

State	Layer	Spring	Summer	Fall	Winter
Idaho	Base/subbase	0.65–0.85	1.00	1.00	0.65–1.00
	Subgrade	0.43–0.90	1.00	1.00	0.27–11.20
Nevada	Base	0.68–0.70	1.00	0.93–0.98	0.87–0.95
	Subgrade	0.70–0.79	1.00	0.85–1.02	0.77–0.81
Minnesota	Base	0.54–1.20	0.84–1.17	1.00	1.00–35.00
	Subgrade	0.73–2.50	0.68–1.10	1.00	13.00–33.00
Washington	Base	0.65–0.85	1.00	0.90	0.75–1.10
	Subgrade	0.85–0.90	1.00	0.90	0.85–1.10
Indiana	Subgrade	0.79–0.87	1.00	—	—

—Indicates no data.

Temperature and moisture effects are also critical for PCC pavements because slab curling (caused by temperature gradients) and slab warping (caused by moisture gradients) significantly influence the deflection response of PCC pavements. For example, Khazanovich, Tayabji, and Darter showed backcalculated  $k$ -values at one location to be up to three times as high because of temperature gradients.<sup>(35)</sup> In addition, temperature effects are more critical on backcalculated  $k$ -values for thinner slabs compared with thicker slabs.<sup>(42)</sup> However, it is primarily large temperature fluctuations (temperatures outside of 7 to 32 °C (45 to 90 °F)) that influence the backcalculated slab modulus and  $k$ -values.<sup>(43)</sup>

None of the existing analysis methods directly accounts for the effects of temperature or moisture in the backcalculation process. Therefore, it is recommended that FWD testing be performed when there is no significant temperature gradient present (e.g., when the ambient air temperature is below 27 °C (80 °F)) to avoid the effects of slab curling on the backcalculated results. Note, however, that avoiding the temperature gradient will not address any built-in curling that may be present in the pavement. Croveti presents a way of differentiating slab curling from poor foundation support using an incremental analysis.<sup>(44)</sup>

### Slab Size Effects

PCC pavement backcalculation procedures based on Westergaard's solutions assume an infinite plate, but in actuality, pavements have a finite length and width. The following approach can be used to correct for slab size effects on a bare PCC pavement during the backcalculation process:<sup>(45)</sup>

1. Compute  $AREA$  (units of inches) for the seven-sensor configuration (sensors spaced at (0, 203, 305, 457, 610, 914, and 1,524 mm (0, 8, 12, 18, 24, 36, and 60 inches)), as described in chapter 2.
2. Compute the estimated radius of relative stiffness ( $\ell_{est}$ ) (units of mm (inches)) for an infinite slab using the equation in figure 32 for the seven-sensor configuration:

$$\ell_{est} = \left[ \frac{\ln\left(\frac{60 - AREA}{289.708}\right)}{-0.698} \right]^{2.566}$$

**Figure 32. Equation. Estimate of radius of relative stiffness for an infinite slab.**

3. Estimate the modulus of subgrade reaction ( $k$ -value) for an infinite slab using figure 33.

$$k_{est} = \frac{P \cdot d_0^*}{d_0 \cdot \ell_{est}^2}$$

**Figure 33. Equation. Estimate of modulus of subgrade reaction for an infinite slab.**

Where:

$k_{est}$  = Modulus of subgrade reaction (MPa/mm (lbf/inch<sup>2</sup>/inch)).

$P$  = Applied load (N (lbf)).

$d_0^*$  = Nondimensional deflection coefficient of deflection at center of load plate =  
 $0.1245e^{[-14707e^{(-07565 \ell_{est})}]}$

$d_0$  = Measured deflection at radial distance  $r$  from the load (mm (inches)).

$\ell_{est}$  = Estimated radius of relative stiffness (mm (inches)).

4. Calculate finite slab size adjustment factors for the deflection directly under the load plate ( $AF_{d_0}$ ) and radius of relative stiffness ( $AF_{\ell_{est}}$ ) using figure 34 and figure 35 equations.

$$AF_{\ell_{est}} = 1.89434e^{-0.61662\left(\frac{L}{\ell_{est}}\right)^{1.04831}}$$

**Figure 34. Equation. Adjustment factor for radius of relative stiffness.**

$$AF_{d_0} = 1 - 1.5085e^{-0.71878\left(\frac{L}{\ell_{est}}\right)^{0.80151}}$$

**Figure 35. Equation. Adjustment factor for deflection directly under load plate.**

Where:

$L = (Ll \times Lw) \times 0.5$  (if the slab length,  $Ll$ , is less than or equal to twice the slab width,  $Lw$ ).

$L = 1.414 \times Ll$  (if the slab length,  $Ll$ , is greater than twice the slab width,  $Lw$ ).

5. Calculate the adjusted  $k$ -value that accounts for slab size effects as shown in figure 36):

$$k = \frac{k_{est}}{(AF_{\ell_{est}})^2 AF_{d_0}}$$

**Figure 36. Equation. Adjusted  $k$ -value calculation for slab size.**

Although the slab size correction procedure is relatively simple and straightforward, it is not always used because of the difficulty in defining the effective length and width of the slab, which are a function of the LTE at the adjacent joints.<sup>(35)</sup>

### Measures of Convergence

In the backcalculation process, the goodness of fit between the calculated deflection basin and the measured deflection basin is referred to as the measure of convergence. The root mean square (RMS) error is one of the more common measures of convergence and can be used to provide a measure of the magnitude of the difference between the calculated and measured deflection basin; it is computed as shown in figure 37.

$$\text{RMS (\%)} = \sqrt{\frac{1}{n_d} \sum_{i=1}^n \left( \frac{d_{ci} - d_{mi}}{d_{mi}} \right)^2} 100$$

**Figure 37. Equation. Determination of RMS error.**

Where:

$n_d$  = Number of deflection sensors used in the backcalculation process.

$d_{ci}$  = Calculated pavement surface deflection at sensor  $i$ .

$d_{mi}$  = Measured pavement surface deflection at sensor  $i$ .

Figure 38 illustrates an example calculation for RMS using the summary of measured and computed deflections provided in table 19.<sup>(27)</sup>

$$\text{RMS (\%)} = \sqrt{\frac{1}{7} \left( \frac{4.90-5.07}{5.07} \right)^2 + \left( \frac{3.94-4.32}{4.32} \right)^2 + \dots + \left( \frac{0.95-1.01}{1.01} \right)^2} 100 = 6.9\%$$

**Figure 38. Equation. Example RMS calculation.**

**Table 19. Example measured and computed pavement deflection data.**

$n_d$	Measured deflections ( $\mu\text{m}$ (mil))	Calculated deflections ( $\mu\text{m}$ (mil))
1	129 (5.07)	125 (4.90)
2	109 (4.32)	100 (3.94)
3	93 (3.67)	89 (3.50)
4	75 (2.99)	78 (3.06)
5	61 (2.40)	67 (2.62)
6	43 (1.69)	47 (1.86)
7	26 (1.01)	24 (0.95)

Based on analysis of LTPP Program data, Von Quintus and Killingsworth suggested that an error term of 2 percent or less was considered reasonable.<sup>(46,47)</sup> The EVERCALC© and MODTAG© user manuals indicate a RMS error of less than 1 percent will result in credible estimates of the layer moduli, whereas layer moduli results with a RMS error greater than 3 percent should be



considered questionable.<sup>(31,48)</sup> Based on these guidelines, the resulting RMS error from the example described in figure 38 and table 19 is considered higher than normally accepted, and therefore resulting layer moduli should be scrutinized.

### Modulus Convergence

In addition to the deflection convergence measure, some backcalculation programs also include convergence criteria based on changes in the estimated moduli. If the change in layer moduli between subsequent iterations is less than a user-specified limit, the backcalculation process will terminate. Figure 39 shows the general form of the modulus convergence equation.<sup>(27)</sup>

$$\text{Modulus Tolerance (MT)} \geq \left( \left| \frac{E_i^{(k+1)} - E_i^{(k)}}{E_i^{(k)}} \right| \right) 100$$

**Figure 39. Equation. Determination of modulus convergence.**

Where:

$MT$  = Difference in layer moduli from one iteration ( $k$ ) to the next ( $k + 1$ ).

$E_i^{(k)}$  = Specific layer modulus for the  $i$ -th layer at the  $k$ th iteration.

$E_i^{(k+1)}$  = Specific layer modulus for the  $i$ -th layer at the ( $k + 1$ )-th iteration.

In general, a modulus convergence of 1 percent is considered acceptable. Large convergence errors suggest that there is a fundamental problem with a specific backcalculation effort. The problem could be within the deflection data (e.g., check that the sensor location in the backcalculation program corresponds to the FWD sensor locations and the precision of the deflection measurement), layer types and thicknesses, or lack of material homogeneity (e.g., cracked and uncracked conditions). Although low convergence errors are desirable, higher convergence errors do not always imply that the backcalculated layer moduli are unreasonable. In this instance, having a good understanding of material properties will greatly assist in balancing the convergence error and reasonable layer moduli.

### Identifying Outliers

One of the more challenging aspects of backcalculation is deciding whether the determined layer modulus values are reasonable. Although evaluating the value of the calculated error is helpful, it does not necessarily guarantee that the results are reasonable. Ultimately, being able to assess the reasonableness of the results is based on knowledge of material parameters and behavior and is gained with experience in the backcalculation process. However, the following items are recommended for investigation when evaluating the validity of the backcalculated modulus values:

- Confirm that the error term is within desired tolerances (e.g., RMS is less than 2 percent).
- Confirm that the backcalculation inputs correspond to the FWD sensor location.
- Confirm the thicknesses of the individual layers. Ideally, the thickness of the HMA layer should be within 13 mm (0.5 inches) of the actual thickness. The base and subbase courses are less sensitive to layer thicknesses.

- Review the FWD data to identify any potential sources for the high error.
- Review the pavement condition to determine whether any unique distresses (e.g., severe rutting or severe cracking) may have led to the high error.

If investigation of these items does not provide any insight regarding the high error term, the data should be considered an outlier and removed from the analysis.

### **Other Effects**

Several other issues may arise during the backcalculation analysis that can affect the results, including the following:<sup>(49)</sup>

- Major cracks in the pavement, or testing near a pavement edge or joint, can cause the deflection data to depart drastically from the assumed conditions.
- Layer thicknesses are often not known or not well defined, and subsurface layers can be overlooked.
- Layer thicknesses are not uniform, and materials in the layers are not homogeneous.
- Some pavement layers are too thin to be backcalculated in the pavement model.
- Random and systematic errors exist in deflection data.

## **VERIFICATION OF BACKCALCULATION RESULTS**

There are potentially two ways to verify the reasonableness of backcalculated modulus values. One way is to compare measured strains with calculated strains, and the other way is to compare backcalculated modulus values with laboratory-based values. These are described in the following subsections.

### **Comparison Based on Strain**

A number of studies have compared strains levels induced by an FWD with those of an instrumented HMA pavement. In one study, Winters conducted an evaluation at a test track pavement consisting of a 140-mm (5.5-inch) HMA layer over a 330-mm (13-inch) granular base.<sup>(50)</sup> HMA cores were instrumented with horizontal and transverse strain gauges and inserted into the existing HMA surface material. An FWD load was applied to induce the strain response (measured by the strain gauges mounted on the cores). The EVERCALC© backcalculation program was then used to determine layer moduli from the measured deflection basins and the corresponding strains.<sup>(27)</sup> The relative agreement between the measured and calculated strains was fairly good, as indicated in figure 40 and figure 41.

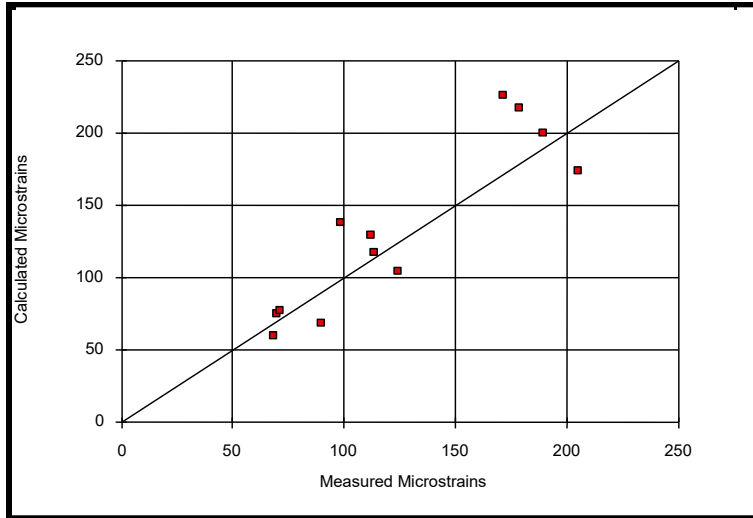

©J.P. Mahoney.

**Figure 40. Graph. Measured versus calculated strain for axial core bottom longitudinal gauges.<sup>(50)</sup>**

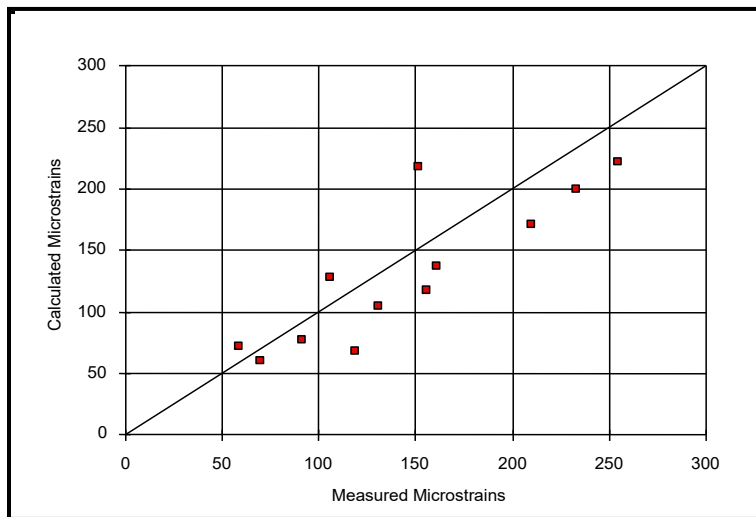

©J.P. Mahoney.

**Figure 41. Graph. Measured versus calculated strain for axial core bottom transverse gauges.<sup>(50)</sup>**

In a study conducted by Lenngren, backcalculated layer moduli, determined using a modified version of EVERCALC®, were used to estimate tensile strain at the bottom of the HMA for two in-place pavement sections.<sup>(51)</sup> In situ tensile strains were measured using strain gauges attached to HMA cores and tested using the FWD. The pavement sections of that study consisted of either 80 or 150 mm (3.1 or 5.9 inches) of HMA over a 550- to 620-mm (22- to 24-inch) gravel and sand base and granular subgrade. The results of the study are shown in figure 42 and figure 43, again showing good agreement between measured and calculated tensile strains.

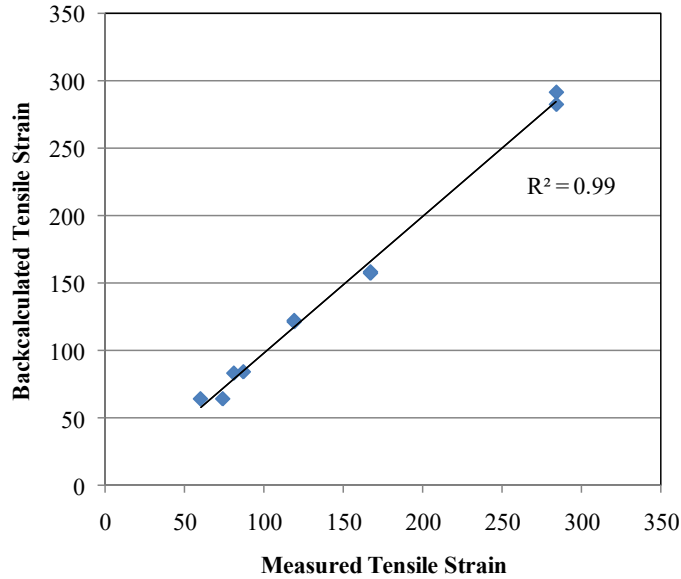

©C.A. Lenngren.

**Figure 42. Graph. Backcalculated versus measured tensile strains (80-mm (3.1-inch) HMA).<sup>(51)</sup>**

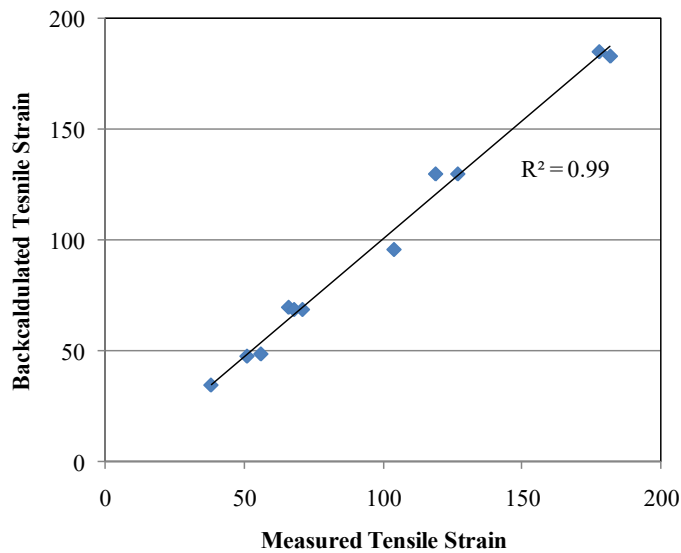

©C.A. Lenngren.

**Figure 43. Graph. Backcalculated versus measured tensile strains (150-mm (5.9-inch) HMA).<sup>(51)</sup>**

In a study conducted by the Minnesota Department of Transportation, in situ strain gauges were monitored during FWD testing and compared with backcalculated strain values from each of several backcalculation programs evaluated (EVERCALC®, WESDEF, and MODCOMP®).<sup>(52)</sup> The Mn/ROAD analysis concluded that the agreement between the expected and backcalculated strain (figure 44 and figure 45) was good for all programs evaluated, especially for the horizontal strain in the asphalt concrete (AC) layer.

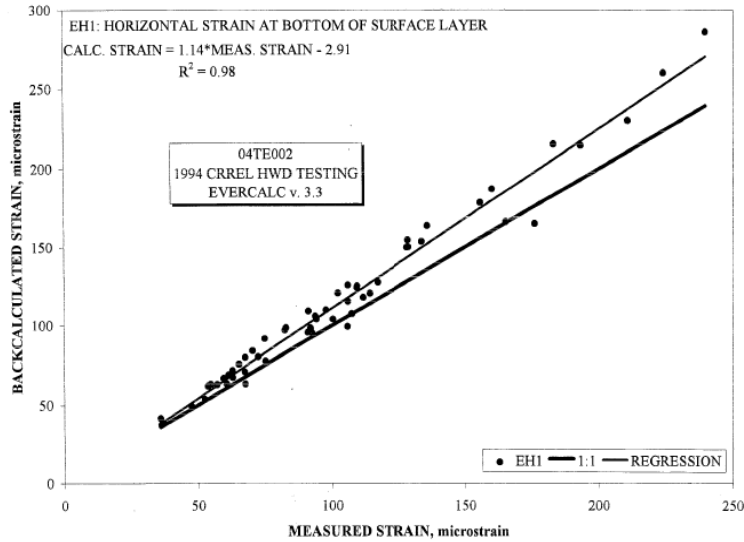

©D. Van Deusen.

**Figure 44. Graph. Comparison of backcalculated (EVERCALC©) and measured AC strain.<sup>(52)</sup>**

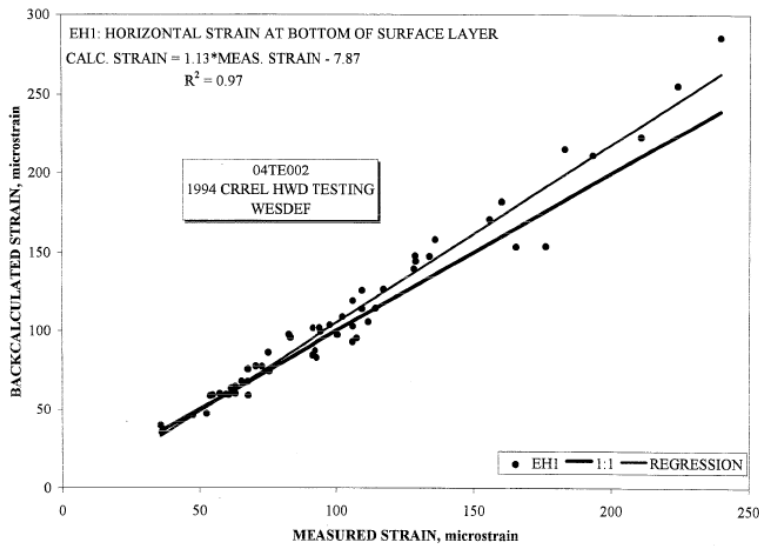

©D. Van Deusen.

**Figure 45. Graph. Comparison of backcalculated (WESDEF) and measured AC strain.<sup>(52)</sup>**

Timm and Priest also conducted a study that measured the strain response due to FWD loading and compared it with the layer moduli estimates from the WESLEA pavement analysis program.<sup>(53)</sup> Conclusions from this analysis determined that the field-measured strain was very similar to the predicted strains using the backcalculated layer moduli (see figure 46).

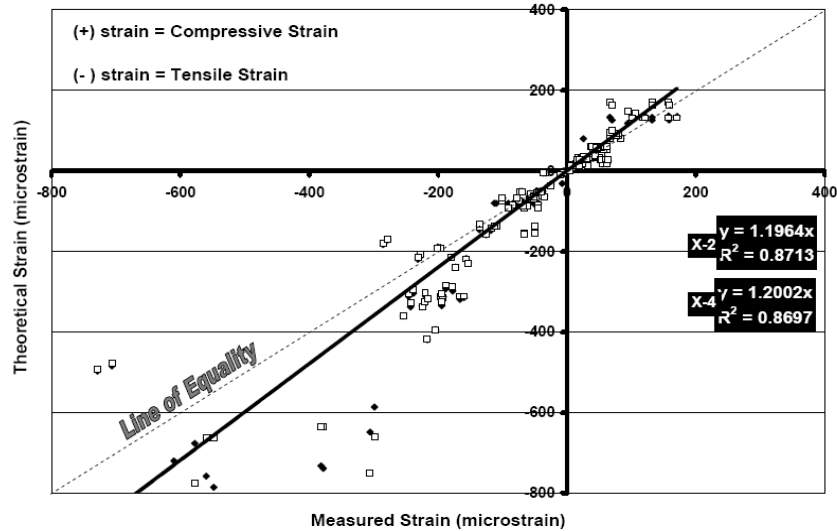

©D.H. Timm.

**Figure 46. Graph. HMA strain comparison.**<sup>(53)</sup>

Appea, Flintsch, and Al-Qadi compared pavement responses (from in situ pressure cells and strain gauges) from the Virginia Smart Road with backcalculated layer moduli from measured FWD deflections.<sup>(54)</sup> Conclusions from this study indicate that, in general, the calculated stresses were comparable to the measured stresses.<sup>(54)</sup>

### Laboratory Versus Backcalculated Moduli

There have been a number of attempts to relate laboratory-based modulus values to those determined from backcalculation, but such comparisons can be problematic for a number of reasons, including the following:<sup>(27)</sup>

- It is difficult to remold laboratory compacted samples (base, subbase, and subgrade) to the exact field structure, density, and/or moisture conditions.
- The induced loading (stress) from FWD testing is different than that of laboratory tests.
- Sampling for laboratory testing may not fully represent field conditions (e.g., sampling a subbase or improved fill material when intending to sample the subgrade soils).
- In situ pavement materials are not homogeneous.

In a study of LTPP Program rigid pavement sections, the backcalculated slab modulus values did not correlate well with the static chord modulus measured in the laboratory under ASTM C469, “Standard Test Method for Static Modulus of Elasticity and Poisson’s Ratio of Concrete in Compression.”<sup>(35,55)</sup> The backcalculated modulus values were substantially higher than the measured static values, part of which was attributed to curling/warping of the slab and also differences in the loading condition.

A number of studies have been conducted to compare backcalculated and laboratory-determined HMA layer moduli. In a study conducted by Zhou, it was determined that backcalculated HMA layer moduli were generally 20 to 30 percent lower than laboratory-measured moduli (tested at the same temperature).<sup>(56)</sup> More recently, Kim, Ji, and Siddiki noted that on average, the modulus determined from FWD testing was approximately two times higher than the laboratory-determined modulus.<sup>(57)</sup> A study by Dawson et al. found a reasonable relationship (see table 20) between laboratory and backcalculated modulus values for the following Unified Soil Classification System (USCS) soil types: gravelly sand (SP1, and SP2), poorly graded sand – silty sand (SP-SM), and clayey sand – silty sand (SC-SM), while noting that differences existed with finer grained soils types.<sup>(58)</sup> In a study on the effects of reflective cracking, researchers found a reasonable match between backcalculated modulus values and laboratory-based values.<sup>(59)</sup>

**Table 20. Backcalculated versus laboratory-obtained subgrade moduli and recommended values for use in the MEPDG.<sup>(58)</sup>**

USCS	AASHTO Soil Type <sup>(60)</sup>	Laboratory		Backcalculation		MEPDG Recommendations <sup>(1)</sup>	
		No. of Tests	Average $M_R$ (MPa (lbf/inch <sup>2</sup> ))	No. of Tests	Average $M_R$ (MPa (lbf/inch <sup>2</sup> ))	Range (MPa (lbf/inch <sup>2</sup> ))	Typical (MPa (lbf/inch <sup>2</sup> ))
SP1	A-1-a A-3	16	199.5 (28,942)	1,241	179.8 (26,073)	169–290 (24,500–42,000)	228 (33,000)
SP2	A-1-b A-3	10	177.1 (25,685)	542	173.6 (25,178)	169–276 (24,500–40,000)	221 (32,000)
SP-SM	A-1-b A-2-4 A-3	8	145.8 (21,147)	383	143.1 (20,760)	169–259 (24,500–37,500)	214 (31,000)
SC-SM	A-2-4 A-4	7	160.4 (23,258)	1,829	140.7 (20,402)	148–259 (21,500–37,500)	200 (29,000)
SM	A-2-4 A-4	17	117.4 (17,028)	182	176.4 (25,583)	148–259 (21,500–37,500)	200 (29,000)
SC	A-2-6 A-6 A-7-6	16	129.3 (18,756)	1,450	158.9 (23,052)	93–214 (13,500–31,000)	152 (22,000)
CL	A-4 A-6 A-7-6	9	256.7 (37,225)	99	156.8 (22,746)	34–200 (5,000–29,000)	117 (17,000)
ML	A-4	4	169.5 (24,578)	23	110.2 (15,976)	117–200 (17,000–29,000)	159 (23,000)

SM = Silty sand.

SC = Low plasticity clay.

ML = Low plasticity silt.

Van Deusen, Lenngren, and Newcomb compared laboratory to backcalculated layer moduli for subgrade soils at the Mn/ROAD facility.<sup>(61)</sup> This study suggested that the laboratory samples and backcalculated layer moduli compared well, within the encountered variability.<sup>(61)</sup> Finally, a study conducted by Houston, Mamlouk, and Perera went a step farther by adding an assessment of quality related to laboratory testing costs.<sup>(62)</sup> That study concluded the following:<sup>(62)</sup>

- Good agreement between laboratory testing and backcalculated results should not be expected because material “heterogeneity in any layer contributes to different measured moduli” between laboratory and field testing.
- Laboratory testing typically costs 60 to 80 times FWD testing.
- Typically, moduli determined from the backcalculation of FWD testing results are “of higher quality and more appropriate for mechanistic pavement design than lab-measured moduli.” The primary contributor to this conclusion is the disturbance during material sampling for laboratory testing.

The intent of this discussion is not to resolve the conflict between laboratory-determined and backcalculated layer moduli. Instead, the intent is to demonstrate potential issues with laboratory test results from field samples (cores of bound materials and remolded unbound materials) and to provide results of a few studies that have compared laboratory and backcalculated layer moduli. The issue of laboratory-based versus backcalculated modulus values commonly comes up in HMA overlay design with regard to whether the backcalculated layer moduli should be “corrected” to laboratory conditions. Although most HMA overlay design procedures rely on the conversion of backcalculated values to those based on laboratory conditions, an understanding of the principles and processes of both laboratory testing and backcalculation are essential for determining appropriate input values. Ultimately, the need for a correction should be based on the experience of the design engineer in concert with knowledge of the local materials and climatic conditions.

## **BACKCALCULATION EXAMPLE**

This section provides an example of the backcalculation process using actual field data (coring, pavement condition assessment, and FWD testing results) from the Washington State Department of Transportation.<sup>(31)</sup>

### **Project Description**

FWD testing was performed on a section of State Route 395 near Chewelah, WA, located in the northeast corner of the State. The pavement at the time of FWD testing (performed in mid-April) exhibited 5 to 15 percent of low- to medium-severity alligator cracking and 30 percent medium- to high-severity longitudinal cracking.

The subgrade was very deep and moderately well drained and classified as a silty loam (i.e., ML). From February to April, a perched water table was present and located at a depth of 600 to 900 mm (24 to 35 inches) beneath the surface. The base material consisted of a silty sandy gravel or sandy gravel and varied in thickness from 300 to 450 mm (12 to 18 inches). The wearing



surface was composed of multiple layers of HMA and chip seal overlays with a total thickness ranging from 100 to 300 mm (3.9 to 11.8 inches). Table 21 presents a summary of the pavement cross section information based on cores taken at various points throughout the project.

**Table 21. Summary of pavement cross section information.**

<b>Core MP Location</b>	<b>Thickness HMA (mm (inches))</b>	<b>Thickness Base (mm (inches))</b>	<b>Comments</b>
207.85	135 (5.3)	457 (18.0)	Core taken at a crack; crack was full depth
208.00	152 (6.0)	457 (18.0)	Core taken at a crack; core not intact
208.50	119 (4.7)	305 (12.0)	Core taken at a crack; crack was full depth
209.00	117 (4.6)	305 (12.0)	Very fatigued; core broke into several pieces
209.05	107 (4.2)	305 (12.0)	Fatigued area; crack was full depth
209.40	150 (5.9)	335 (13.2)	Core taken at a crack; crack was full depth
209.80	165 (6.5)	396 (15.6)	HMA core intact
210.00	112 (4.4)	366 (14.4)	Fatigue in both wheel paths; crack was full depth
210.50	249 (9.8)	366 (14.4)	Core taken at a crack; crack was full depth
211.00	229 (9.0)	366 (14.4)	Core broke into several pieces
211.50	282 (11.1)	366 (14.4)	HMA core intact
212.00	300 (11.8)	366 (14.4)	HMA core intact
212.50	229 (9.0)	366 (14.4)	Top 183 mm (7.2 inches) in good condition

Because of the presence of the perched water table, there was the potential for a stiff layer to be encountered as part of the backcalculation process. Therefore, the following three backcalculation approaches were considered:

- Assume that no stiff layer exists.
- Assume a stiff layer with a modulus of 345 MPa (50,000 lbf/inch<sup>2</sup>), which indicates a moist or saturated layer.
- Assume a stiff layer with a modulus of 6,900 MPa (1 million lbf/inch<sup>2</sup>), which indicates a rock layer or stiff deposit.

### **Input Values**

The number of layers to be modeled for this problem ranged from three (if a stiff layer did not exist) to four (if a stiff layer existed). Table 22 summarizes the layer information and initial assumptions/ranges for modulus values. The FWD testing employed a six-sensor configuration with sensor spacings of 0, 203, 305, 610, 914, and 1219 mm (0, 8, 12, 24, 36, and 48 inches). FWD data were normalized to a standard loading of 40 kN (9,000 lbf), with the resultant normalized deflection data presented in table 23. The pavement temperature at the time of FWD testing was between 8 and 10 °C (46 and 50 °F).

**Table 22. Input values to represent pavement layers.**

Layer	Description	Poisson's Ratio	Modulus (MPa (lbf/inch <sup>2</sup> ))		
			Initial	Minimum	Maximum
1	HMA	0.35	2,700 (400,000)	690 (100,000)	13,800 (2 million)
2	Base	0.40	170 (25,000)	35 (5,000)	3,500 (500,000)
3	Subgrade	0.45	100 (15,000)	35 (5,000)	3,500 (500,000)
4 <sup>a</sup>	Stiff layer (water)	0.35	345 (50,000)	—	—
4 <sup>a</sup>	Stiff layer (rock)	0.30	6,900 (1 million)	—	—

<sup>a</sup>Denotes the use of a stiff layer.

—Indicates not applicable.

### Backcalculation Results

The EVERCALC© program was used in the backcalculation analysis of the FWD data collected for this project. It is briefly described in this subsection along with a presentation and discussion of the overall results.

#### *EVERCALC©*

EVERCALC© uses the Levenberg-Marquardt minimization algorithm that seeks to minimize an objective function formed as the sum of squared relative differences between the calculated and measured surface deflections.<sup>(63)</sup> EVERCALC© employs the WESLEA computer program for forward calculations; has the option for including stress sensitivity of unstabilized materials and stresses and strains at various depths; and optionally normalizes HMA modulus to a standard temperature. The program uses an iterative approach in changing the moduli to match theoretical and measured deflections and was specifically developed to backcalculate layer moduli of flexible pavements.

#### *Discussion of Results*

The backcalculation results obtained from the EVERCALC© program are shown in table 24. The  $E_{adj}$  columns are the backcalculated HMA modulus values adjusted to a standard temperature of 25 °C (77 °F), while the  $E_{HMA}$  columns are the backcalculated HMA modulus values at the actual field testing temperatures.

**Table 23. FWD deflections and normalized deflection to 40 kN (9,000 lbf).**

<b>MP Location</b>	<b>Load (kN (lbf))</b>	<b><math>D_0</math> (<math>\mu\text{m}</math> (mil))</b>	<b><math>D_{200\text{ mm (8 in)}}</math> (<math>\mu\text{m}</math> (mil))</b>	<b><math>D_{305\text{ mm (12 in)}}</math> (<math>\mu\text{m}</math> (mil))</b>	<b><math>D_{610\text{ mm (24 in)}}</math> (<math>\mu\text{m}</math> (mil))</b>	<b><math>D_{915\text{ mm (36 in)}}</math> (<math>\mu\text{m}</math> (mil))</b>	<b><math>D_{1220\text{ mm (48 in)}}</math> (<math>\mu\text{m}</math> (mil))</b>
207.85	75 (16,940)	795 (31.30)	665 (26.18)	589 (23.19)	350 (13.78)	231 (9.09)	169 (6.65)
	54 (12,086)	615 (24.21)	516 (20.31)	460 (18.11)	263 (10.35)	173 (6.81)	126 (4.96)
	42 (9,421)	494 (19.45)	416 (16.38)	370 (14.57)	206 (8.11)	134 (5.28)	101 (3.98)
	28 (6,218)	335 (13.19)	286 (11.26)	252 (9.92)	130 (5.12)	86 (3.39)	72 (2.83)
Normalized Deflection		467 (18.39)	394 (15.51)	350 (13.78)	193 (7.60)	127 (5.00)	97 (3.82)
208.00	76 (16,987)	687 (27.04)	547 (21.53)	472 (18.58)	286 (11.26)	186 (7.32)	134 (5.28)
	54 (12,070)	540 (21.26)	431 (16.97)	371 (14.61)	220 (8.66)	141 (5.55)	101 (3.98)
	42 (9,405)	445 (17.52)	354 (13.94)	304 (11.97)	178 (7.01)	113 (4.45)	82 (3.23)
	28 (6,186)	313 (12.32)	248 (9.76)	211 (8.31)	118 (4.65)	73 (2.87)	52 (2.05)
Normalized Deflection		421 (16.57)	336 (13.23)	288 (11.34)	167 (6.57)	106 (4.17)	76 (2.99)
208.50	75 (16,829)	379 (14.92)	302 (11.89)	260 (10.23)	150 (5.91)	81 (3.19)	58 (2.28)
	54 (12,245)	296 (11.65)	236 (9.29)	202 (7.95)	114 (4.49)	54 (2.13)	44 (1.73)
	42 (9,533)	244 (9.61)	194 (7.63)	166 (6.53)	92 (3.62)	46 (1.81)	33 (1.30)
	28 (6,297)	171 (6.73)	136 (5.35)	114 (4.49)	61 (2.40)	32 (1.26)	22 (0.87)
Normalized Deflection		229 (9.01)	182 (7.17)	155 (6.10)	86 (3.39)	43 (1.69)	32 (1.26)
209.00	73 (16,305)	1,505 (59.25)	1,234 (48.58)	1,080 (42.52)	541 (21.30)	242 (9.53)	130 (5.12)
	52 (11,737)	1,172 (46.14)	953 (37.52)	827 (32.56)	396 (15.59)	170 (6.69)	91 (3.58)
	41 (9,247)	938 (36.93)	757 (29.8)	651 (25.63)	299 (11.77)	126 (4.96)	68 (2.68)
	27 (6,154)	635 (25.00)	505 (19.88)	426 (16.77)	185 (7.28)	77 (3.03)	44 (1.73)
Normalized Deflection		902 (35.51)	728 (28.66)	625 (24.61)	290 (11.42)	123 (4.84)	67 (2.64)
209.05	71 (15,972)	1,426 (56.14)	1,140 (44.88)	969 (38.15)	556 (21.89)	344 (13.54)	236 (9.29)
	51 (11,531)	1,118 (44.02)	894 (35.20)	751 (29.57)	415 (16.34)	254 (10.00)	174 (6.85)
	40 (9,088)	905 (35.63)	718 (28.27)	597 (23.50)	321 (12.64)	191 (7.52)	128 (5.04)
	27 (5,995)	644 (25.35)	488 (19.21)	392 (15.43)	190 (7.48)	118 (4.65)	710 (2.80)
Normalized Deflection		893 (35.16)	702 (27.64)	581 (22.87)	311 (12.24)	189 (7.44)	125 (4.92)

<b>MP Location</b>	<b>Load (kN (lbf))</b>	<b><math>D_0</math> (<math>\mu\text{m}</math> (mil))</b>	<b><math>D_{200\text{ mm (8 in)}}</math> (<math>\mu\text{m}</math> (mil))</b>	<b><math>D_{305\text{ mm (12 in)}}</math> (<math>\mu\text{m}</math> (mil))</b>	<b><math>D_{610\text{ mm (24 in)}}</math> (<math>\mu\text{m}</math> (mil))</b>	<b><math>D_{915\text{ mm (36 in)}}</math> (<math>\mu\text{m}</math> (mil))</b>	<b><math>D_{1220\text{ mm (48 in)}}</math> (<math>\mu\text{m}</math> (mil))</b>
209.40	71 (16,004)	1,597 (62.87)	1,316 (51.81)	1,106 (43.54)	631 (24.84)	377 (14.84)	244 (9.61)
	52 (11,610)	1,268 (49.92)	1,044 (41.10)	871 (34.29)	491 (19.33)	293 (11.54)	189 (7.44)
	40 (9,104)	1,020 (40.16)	846 (33.31)	696 (27.40)	382 (15.04)	227 (8.94)	145 (5.71)
	30 (6,733)	725 (28.54)	581 (22.87)	466 (18.35)	241 (9.49)	145 (5.71)	94 (3.70)
Normalized Deflection		1,002 (39.45)	821 (32.32)	675 (26.57)	369 (14.53)	220 (8.66)	142 (5.59)
209.80	77 (17,257)	677 (26.65)	548 (21.57)	475 (18.70)	286 (11.26)	182 (7.17)	126 (4.96)
	54 (12,229)	528 (20.79)	429 (16.89)	371 (14.61)	220 (8.66)	137 (5.39)	94 (3.70)
	42 (9,533)	426 (16.77)	347 (13.66)	298 (11.73)	171 (6.73)	107 (4.21)	72 (2.83)
	28 (6,265)	298 (11.73)	240 (9.45)	203 (7.99)	111 (4.37)	69 (2.72)	44 (1.73)
Normalized Deflection		402 (15.83)	326 (12.83)	280 (11.02)	160 (6.30)	100 (3.94)	67 (2.64)
210.00	74 (16,718)	914 (35.98)	742 (29.21)	639 (25.16)	426 (16.77)	285 (11.22)	197 (7.76)
	53 (12,023)	706 (27.80)	650 (25.60)	490 (19.29)	323 (12.72)	213 (8.39)	145 (5.71)
	42 (9,422)	567 (22.32)	457 (17.99)	388 (15.28)	250 (9.84)	162 (6.38)	111 (4.37)
	27 (6,170)	385 (15.16)	307 (12.09)	256 (10.08)	160 (6.30)	101 (3.98)	70 (2.76)
Normalized Deflection		538 (21.18)	434 (17.09)	367 (14.45)	236 (9.29)	154 (6.06)	105 (4.13)
210.50	76 (17,162)	568 (22.36)	488 (19.21)	423 (16.65)	265 (10.43)	175 (6.89)	120 (4.72)
	54 (12,213)	441 (17.36)	380 (14.96)	329 (12.95)	201 (7.91)	128 (5.04)	89 (3.50)
	42 (9,437)	355 (13.98)	306 (12.05)	264 (10.39)	159 (6.26)	100 (3.94)	68 (2.68)
	27 (6,170)	244 (9.61)	210 (8.27)	179 (7.05)	104 (4.09)	63 (2.48)	42 (1.65)
Normalized Deflection		336 (13.22)	289 (11.38)	249 (9.80)	149 (5.87)	93 (3.66)	64 (2.52)
211.00	76 (17,178)	344 (13.54)	300 (11.81)	278 (10.94)	204 (8.03)	154 (6.06)	116 (4.57)
	55 (12,324)	264 (10.39)	226 (8.90)	209 (8.23)	155 (6.10)	116 (4.57)	85 (3.35)
	43 (9,628)	203 (7.99)	181 (7.13)	166 (6.54)	122 (4.80)	90 (3.54)	66 (2.60)
	28 (6,392)	144 (5.67)	121 (4.76)	109 (4.29)	80 (3.15)	58 (2.28)	43 (1.69)
Normalized Deflection		194 (7.64)	168 (6.61)	153 (6.02)	113 (4.45)	83 (3.27)	61 (2.40)
211.50	78 (17,463)	320 (12.60)	266 (10.47)	239 (9.41)	169 (6.65)	119 (4.69)	82 (3.23)
	56 (12,626)	234 (9.21)	195 (7.68)	175 (6.89)	123 (4.84)	87 (3.42)	59 (2.32)

<b>MP Location</b>	<b>Load (kN (lbf))</b>	<b><math>D_0</math> (<math>\mu\text{m}</math> (mil))</b>	<b><math>D_{200\text{ mm (8 in)}}</math> (<math>\mu\text{m}</math> (mil))</b>	<b><math>D_{305\text{ mm (12 in)}}</math> (<math>\mu\text{m}</math> (mil))</b>	<b><math>D_{610\text{ mm (24 in)}}</math> (<math>\mu\text{m}</math> (mil))</b>	<b><math>D_{915\text{ mm (36 in)}}</math> (<math>\mu\text{m}</math> (mil))</b>	<b><math>D_{1220\text{ mm (48 in)}}</math> (<math>\mu\text{m}</math> (mil))</b>
	44 (9,881)	179 (7.05)	150 (5.91)	134 (5.28)	93 (3.66)	65 (2.56)	44 (1.73)
	29 (6,487)	113 (4.45)	94 (3.70)	83 (3.27)	57 (2.24)	40 (1.57)	27 (1.06)
Normalized Deflection		162 (6.38)	135 (5.31)	121 (4.76)	84 (3.31)	59 (2.32)	40 (1.57)
212.00	79 (17,717)	570 (22.44)	519 (20.43)	483 (19.01)	362 (14.25)	269 (10.59)	199 (7.83)
	56 (12,626)	431 (16.97)	392 (15.43)	364 (14.33)	272 (10.71)	201 (7.91)	149 (5.87)
	45 (10,024)	340 (13.39)	310 (12.20)	187 (7.36)	215 (8.46)	158 (6.22)	118 (4.65)
	29 (6,582)	218 (8.59)	204 (8.03)	188 (7.40)	139 (5.47)	103 (4.06)	76 (2.99)
Normalized Deflection		306 (12.04)	278 (10.94)	257 (10.11)	192 (7.56)	142 (5.59)	105 (4.13)
212.5	81 (18,193)	495 (19.49)	441 (17.36)	407 (16.02)	316 (12.44)	242 (9.53)	177 (6.97)
	58 (12,927)	382 (15.04)	337 (13.27)	310 (12.20)	241 (9.49)	183 (7.20)	135 (5.31)
	46 (10,294)	296 (11.65)	267 (10.51)	244 (9.61)	191 (7.52)	144 (5.67)	102 (4.02)
	30 (6,789)	206 (8.11)	178 (7.01)	161 (6.34)	125 (4.92)	93 (3.66)	64 (2.52)
Normalized Deflection		266 (10.47)	235 (9.26)	214 (8.42)	167 (6.57)	125 (4.92)	89 (3.50)

**Table 24. Summary of EVERCALC© backcalculation results.**

FWD/ Core MP Location	No Stiff Layer					Depth to Stiff Layer (m (inches))	Stiff Layer at 345 MPa (50 ksi)					Stiff Layer at 6,900 MPa (1,000 ksi)				
	<i>E<sub>adj</sub></i> (MPa (ksi))	<i>E<sub>hma</sub></i> (MPa (ksi))	<i>E<sub>base</sub></i> (MPa (ksi))	<i>E<sub>sub</sub></i> (MPa (ksi))	RMS		<i>E<sub>adj</sub></i> (MPa (ksi))	<i>E<sub>hma</sub></i> (MPa (ksi))	<i>E<sub>base</sub></i> (MPa (ksi))	<i>E<sub>sub</sub></i> (MPa (ksi))	RMS	<i>E<sub>adj</sub></i> (MPa (ksi))	<i>E<sub>hma</sub></i> (MPa (ksi))	<i>E<sub>base</sub></i> (MPa (ksi))	<i>E<sub>sub</sub></i> (MPa (ksi))	RMS
207.85	1,138 (165)	3,640 (528)	117 (17)	83 (12)	3.09	4.95 (195)	981 (142)	3,137 (455)	152 (22)	69 (10)	4.12	931 (135)	2,972 (431)	165 (24)	62 (9)	4.53
208.00	903 (131)	2,882 (418)	124 (18)	103 (15)	0.70	4.04 (159)	738 (107)	2,351 (341)	165 (24)	83 (12)	1.80	676 (98)	2,165 (314)	193 (28)	69 (10)	2.52
208.50	3,654 (530)	1,703 (247)	117 (17)	248 (36)	3.39	1.55 (61)	2,537 (368)	8,115 (1,177)	296 (43)	152 (22)	5.37	1,400 (203)	4,482 (650)	758 (110)	34 (9)	10.73
209.00	607 (88)	1,951 (283)	34 (5)	90 (13)	13.40	1.19 (47)	1,733 (251)	5,550 (805)	117 (17)	34 (5)	24.56	2,530 (367)	8,418 (1,221)	34 (5)	34 (5)	41.88
209.05	1,165 (169)	3737 (542)	41 (6)	62 (9)	2.04	2.49 (98)	621 (90)	1,979 (287)	131 (19)	34 (5)	5.29	1,276 (185)	4,082 (592)	83 (12)	34 (5)	10.12
209.40	414 (60)	1,331 (193)	34 (5)	55 (8)	2.00	2.16 (85)	648 (94)	2,068 (300)	34 (5)	34 (5)	14.39	655 (95)	2,089 (303)	34 (5)	34 (5)	21.76
209.80	979 (142)	3,123 (453)	83 (12)	117 (17)	0.96	3.61 (142)	779 (113)	2,503 (363)	145 (21)	90 (13)	1.60	689 (100)	2,213 (321)	179 (26)	76 (11)	2.41
210.00	2,048 (297)	6,557 (951)	97 (14)	69 (10)	2.29	3.23 (127)	1,138 (165)	3,640 (528)	200 (29)	48 (7)	0.83	1,000 (145)	3,199 (464)	228 (33)	41 (6)	0.99
210.50	4,868 (706)	17,037 (2,471)	117 (17)	117 (17)	0.64	8.64 (340)	4,406 (639)	15,417 (2,236)	145 (21)	117 (17)	0.76	4,151 (602)	14,534 (2,108)	165 (24)	110 (16)	0.85
211.00	1,882 (273)	6,578 (954)	145 (21)	138 (20)	0.76	5.69 (224)	1,903 (276)	6,660 (966)	193 (28)	124 (18)	0.63	1,793 (260)	6,288 (912)	262 (38)	103 (15)	0.68
211.50	1,317 (191)	4,606 (668)	83 (12)	255 (37)	0.66	3.05 (120)	1269 (184)	4,447 (645)	124 (18)	207 (30)	0.67	1,158 (168)	4,054 (588)	269 (39)	110 (16)	1.13
212.00	827 (120)	2,889 (419)	34 (5)	97 (14)	2.08	7.98 (314)	876 (127)	3,061 (444)	34 (5)	90 (13)	1.88	896 (130)	3,130 (454)	34 (5)	83 (12)	1.86
212.50	1,965 (285)	6,888 (999)	34 (5)	124 (18)	1.23	5.13 (202)	1,924 (279)	1,924 (279)	69 (10)	90 (13)	0.97	1,834 (266)	6,426 (932)	103 (15)	76 (11)	0.86

### *No Stiff Layer Scenario*

In general, the adjusted HMA modulus values appear to be reasonable (within the expected moduli range for a fatigued HMA) for this aged and distressed HMA pavement. At MP location 210.50, the resulting adjusted HMA moduli was very high considering that the HMA was cracked full depth at this location. Reviewing the results for the base layer, it is noted that for the most part, the base layer moduli were higher than those determined for the subgrade, which was an expected outcome (although it may occasionally be possible for the backcalculated subgrade moduli to be equal to or slightly higher than the backcalculated base moduli). The backcalculated moduli of 35 MPa (5,000 lbf/inch<sup>2</sup>) for the base and subgrade moduli was the minimum value specified in the EVERCALC© program, which was the result at several locations for the base layer. The RMS error for more than half of the locations (54 percent) was below the recommended 2-percent threshold.

### *Stiff Layer at 345 MPa (50,000 lbf/inch<sup>2</sup>)*

In this scenario (in which a stiff layer was assumed with a fixed modulus of 345 MPa (50,000 lbf/inch<sup>2</sup>)), the HMA modulus still appears reasonable and the base layer modulus, for the most part, increased slightly to more reasonable values. The subgrade modulus was lowered a bit from the first scenario but is still in the reasonable range for this soil type. In this scenario, 62 percent (or one more location than the first scenario) of the backcalculated moduli resulted in an RMS error below 2 percent.

### *Stiff Layer at 6,900 MPa (1 million lbf/inch<sup>2</sup>)*

This scenario assumed a stiff layer with a fixed modulus of 6,900 MPa (1 million lbf/inch<sup>2</sup>). This analysis produces generally reasonable HMA modulus values and yields base layer moduli within the expected range for about half of the locations; it also produces slightly lower subgrade moduli but ones that are still within the range of expected values. Under this scenario, fewer than half (approximately 46 percent) of the locations had a resulting RMS error below 2 percent.

### *Selection of Moduli*

Of the 13 locations evaluated, only 1 location, MP 209.00, consistently resulted in a very high RMS error under all three scenarios. Consequently, that point was considered an outlier and should not be considered as representative of the typical conditions. Several other locations produced RMS errors above the 2 percent criterion, but in most of those cases, one of the two stiff layer scenarios produced reasonable values. Ultimately, it is up to the engineer to decide which set of backcalculated modulus values is the most reasonable for each location, based on experience and knowledge of the in situ conditions. In general, the backcalculated moduli using a stiff layer at 345 MPa (50,000 lbf/inch<sup>2</sup>) appears to have the most locations in the range of expected values for this roadway section. Based on the information provided in this example, table 25 summarizes recommended moduli and provides a brief discussion on the reasoning behind the selection of the particular layer moduli results.

**Table 25. Summary of selected layer moduli.**

<b>MP Location</b>	<b><math>E_{HMA}</math> MPa (lbf/inch<sup>2</sup>)</b>	<b><math>E_{Base}</math> MPa (lbf/inch<sup>2</sup>)</b>	<b><math>E_{Sub}</math> MPa (lbf/inch<sup>2</sup>)</b>	<b><i>RMS</i></b>	<b>Scenario<sup>1</sup></b>	<b>Discussion</b>
207.85	981 (142,000)	152 (22,000)	69 (10,000)	4.12	1	High RMS. Results in realistic base moduli. Stiff layer at 6,900 MPa (1 million lbf/inch <sup>2</sup> ) would also be appropriate, but higher RMS.
208.00	738 (107,000)	165 (24,000)	83 (12,000)	1.80	1	Realistic layer moduli. No stiff layer results in base moduli a bit low for this roadway section. High stiff layer case results in higher RMS.
208.50	2,537 (368,000)	296 (43,000)	152 (22,000)	5.37	1	High RMS. No stiff layer results in too low base moduli though lower RMS. High stiff layer case results in too high base moduli.
209.00	—	—	—	—	—	Unreasonable layer moduli and RMS considerably higher than 2 percent. Results not recommended for use.
209.05	621 (90,000)	131 (19,000)	34 (5,000)	5.29	1	High RMS; layer moduli look reasonable. No stiff layer results in low base moduli. High stiff layer results in high RMS.
209.40	—	—	—	—	—	No stiff layer has good RMS, but layer moduli all too low. Results not recommended for use.
209.80	779 (113,000)	145 (21,000)	90 (13,000)	1.60	1	No stiff layer and stiff layer result in reasonable RMS. Stiff layer has more reasonable base layer moduli.



<b>MP Location</b>	<b><math>E_{HMA}</math> MPa (lbf/inch<sup>2</sup>)</b>	<b><math>E_{Base}</math> MPa (lbf/inch<sup>2</sup>)</b>	<b><math>E_{Sub}</math> MPa (lbf/inch<sup>2</sup>)</b>	<b><math>RMS</math></b>	<b>Scenario<sup>1</sup></b>	<b>Discussion</b>
210.00	1,138 (165,000)	200 (29,000)	48 (7,000)	0.83	1	Stiff and high stiff layer result in reasonable RMS. Either could be used, stiff layer selected because of lower RMS.
210.50	4,151 (602,000)	165 (24,000)	110 (116,000)	0.85	2	All scenarios result in low RMS. High stiff layer results in more reasonable base moduli for this roadway section.
211.00	1,903 (276,000)	193 (28,000)	124 (18,000)	0.63	1	All scenarios result in low RMS. High stiff layer results in higher base moduli than expected for this roadway section.
211.50	1,158 (168,000)	269 (39,000)	110 (16,000)	1.13	2	All scenarios result in low RMS. No stiff layer and stiff layer result in too low base moduli for this roadway section.
212.00	896 (130,000)	34 (5,000)	83 (12,000)	1.86	2	Stiff and high stiff scenarios result in low RMS. All scenarios result in too low base moduli.
212.50	1,834 (266,000)	103 (15,000)	76 (11,000)	0.86	2	All scenarios result in low RMS. High stiff layer results in more reasonable base moduli for this roadway section.

<sup>1</sup>Scenario 1 = Stiff layer at 345 MPa (50,000 lbf/inch<sup>2</sup>)—stiff layer. Scenario 2 = Stiff layer at 6,900 MPa (1 million lbf/inch<sup>2</sup>)—high stiff layer.

—Indicates results not recommended for use.

## SUMMARY

This chapter provides an overview of the backcalculation process and recommended guidelines for backcalculation of flexible, rigid, and composite pavements. General backcalculation recommendations are summarized as follows:

- **Number of layers:** Three or four, ideally no more than three layers (combine similar layers if needed).
- **Layer thickness.**

- **HMA:** Not recommended for layers less than 75 mm (3 inches); all bituminous layers should be combined.
  - **PCC:** No known limitations.
  - **Unstabilized base/subbase:** If backcalculation results in unrealistic layer moduli and the base is relatively thin, consider combining base thickness into the subgrade to potentially reduce the error.
  - **Subgrade:** If backcalculation results in high error, determine/evaluate the presence of a stiff layer (bedrock, saturated layer, or water table).
- **Initial moduli ranges.**
    - **Sound HMA:** 2,000–4,000 MPa (300,000–600,000 lbf/inch<sup>2</sup>).
    - **Fatigued HMA:** 700–1,400 MPa (100,000–200,000 lbf/inch<sup>2</sup>).
    - **PCC:** 20,000–27,500 MPa (3 million–4 million lbf/inch<sup>2</sup>).
    - **Unstabilized base/subbase:** 100–345 MPa (15,000–50,000 lbf/inch<sup>2</sup>); see also table 10.
    - **Stabilized base:** 2,000–4,000 MPa (300,000–600,000 lbf/inch<sup>2</sup>); see also table 11.
    - **Subgrade:** 41–345 MPa (6,000–50,000 lbf/inch<sup>2</sup>); see also table 12.
  - **Poisson's ratio.**
    - **HMA:** 0.35.
    - **PCC:** 0.15–0.20.
    - **Unstabilized base/subbase:** 0.35.
    - **Stabilized base:** 0.25–0.35.
    - **Subgrade:** 0.35–0.45.

In addition, table 26 provides a summary of guidance for dealing with a number of specific issues in the backcalculation of flexible, rigid, and composite pavement systems.

**Table 26. Addressing specific conditions in pavement backcalculation analysis.**

<b>Pavement Type</b>	<b>Situation</b>	<b>Issue(s)</b>	<b>Recommendation(s)</b>
Flexible	Multiple bituminous lifts/layers	<ul style="list-style-type: none"> <li>• Many backcalculation programs limit the total number of layers to five (including a stiff layer).</li> <li>• Typically, backcalculation programs are insensitive to differentiating moduli values between adjacent similar stiffness bituminous layers.</li> </ul>	<ul style="list-style-type: none"> <li>• Combine adjacent bituminous lifts/layers.</li> <li>• If total thickness is less than 75 mm (3 inches), assume a fixed modulus for the combined layer.</li> </ul>
	More than five structural layers	<ul style="list-style-type: none"> <li>• Many backcalculation programs limit the total number of layers to five (including a stiff layer).</li> <li>• As the number of layers increases, the error level may increase and result in an unreasonable solution.</li> </ul>	<ul style="list-style-type: none"> <li>• Combine adjacent layers of similar materials or stiffness (e.g., bituminous layers, granular base and subbase).</li> <li>• Ideally, no more than four layers (surfacing, base, subgrade, and stiff layer, when applicable) should be modeled.</li> </ul>
	Thin surfacing layers (< 75 mm (3 inches))	<ul style="list-style-type: none"> <li>• Thin bituminous layers have minimal influence on the surface deflection.</li> <li>• Unreasonable moduli for the thin bituminous layer may result.</li> <li>• A high error level may result.</li> </ul>	<ul style="list-style-type: none"> <li>• Combine thin surface layer with adjacent bituminous layer(s).</li> <li>• Assume a fixed modulus for the bituminous layer.</li> </ul>
	Highly distressed surface (e.g., alligator cracking, stripping)	<ul style="list-style-type: none"> <li>• Highly distressed pavements violate the layered-elastic theory of homogeneity.</li> <li>• Deflection basin may not produce the smooth basin predicted by layered-elastic theory.</li> </ul>	<ul style="list-style-type: none"> <li>• Assume a fixed layer modulus for the bituminous layer.</li> <li>• Consider using only the backcalculated results for the unbound layer moduli.</li> <li>• Remove data points from analysis (condition should be well documented during testing).</li> </ul>
	Bonding condition	Significant debonding/delamination of adjacent bituminous lifts/layers can result in unreasonable modulus values and higher error levels.	<ul style="list-style-type: none"> <li>• Confirm bond condition (coring) where delamination may be an issue.</li> <li>• Assume a fixed layer modulus for the bituminous layer.</li> </ul>

<b>Pavement Type</b>	<b>Situation</b>	<b>Issue(s)</b>	<b>Recommendation(s)</b>
	Elevated testing temperatures	<ul style="list-style-type: none"> <li>• Bituminous layers are very sensitive to changes in temperature.</li> <li>• On extremely hot days, the bituminous layer will have a significantly lower modulus.</li> <li>• Increased error levels may result.</li> </ul>	<ul style="list-style-type: none"> <li>• Do not conduct deflection testing when pavement temperatures are above 32 °C (90 °F).</li> <li>• Apply temperature correction factor for bituminous layer.</li> <li>• Assume a fixed layer modulus for the bituminous layer.</li> </ul>
	Saturated soils	In the backcalculation process, saturated soils can have a similar affect as a stiff layer.	If a saturated layer is known to exist, consider evaluating this layer as a stiff layer (see comments for a stiff layer).
	Frozen subgrade	See discussion on presence of rigid layer.	<ul style="list-style-type: none"> <li>• Conduct deflection testing during unfrozen conditions.</li> <li>• Include use of seasonal moduli in pavement design process.</li> </ul>
	Non-decreasing layer stiffness with depth	<ul style="list-style-type: none"> <li>• Some backcalculation programs include a built-in assumption that layer moduli decrease with depth.</li> <li>• Deflection of lower stiffness layer has minimal influence on deflection.</li> <li>• Unreasonable moduli for the layer above the stiffer layer may result.</li> </ul>	<ul style="list-style-type: none"> <li>• Confirm backcalculation program assumptions.</li> <li>• Review results for reasonable moduli and RMS values.</li> <li>• Assume a fixed modulus for the bituminous layer.</li> </ul>
	Compacted subgrade layers (sub-layering subgrade)	<ul style="list-style-type: none"> <li>• Treated materials often have higher moduli than the underlying subgrade.</li> <li>• If unaccounted for, these layers can result in unreasonable layer moduli and higher error levels.</li> </ul>	For treated materials (e.g., lime- or cement-stabilized subgrade), consider as a base/subbase layer; may need to combine with base/subbase course if results in more than three layers to analyze.
	Presence of stiff layer (e.g., bedrock, saturated layer, water table)	Stiff layers located at a shallow depth (< 12 m (40 ft)) may result in unreasonable backcalculated moduli in the upper layers and higher error levels.	<ul style="list-style-type: none"> <li>• When possible, confirm location of bedrock, stiff layer, or shallow water table (borings, soil surveys).</li> <li>• Run multiple backcalculation analyses that include stiff layer at varying depths and stiffnesses.</li> </ul>

<b>Pavement Type</b>	<b>Situation</b>	<b>Issue(s)</b>	<b>Recommendation(s)</b>
Rigid	Cement-treated or lean concrete base	<ul style="list-style-type: none"> <li>• A bonding condition between base and slab affects backcalculated modulus.</li> <li>• AREA-based methods compute effective modulus of bound (stiffer) layers, and a layer ratio is used to determine individual layer moduli.</li> </ul>	<ul style="list-style-type: none"> <li>• Review results for reasonable moduli.</li> <li>• Conduct investigation to determine bonding conditions.</li> <li>• Conduct materials testing to validate assumed layer ratio.</li> </ul>
	Presence of stiff layer (e.g., bedrock, saturated layer, water table)	A composite $k$ -value is determined, which includes the influence of any stiff layer, if present.	Ensure the use of a compatible model in the design method.
	Elevated testing temperatures	<ul style="list-style-type: none"> <li>• Curling of the slab may increase variability of backcalculated values.</li> <li>• Joint LTE values may be artificially high.</li> </ul>	Conduct deflection testing when ambient air temperature is below 30 °C (85 °F).
	Small PCC slab sizes	Joint (or crack) discontinuity near the applied load influences results.	<ul style="list-style-type: none"> <li>• Review results for reasonable moduli.</li> <li>• Assess impact of the use of slab size adjustments on the reasonableness of moduli.</li> </ul>
	More than two structural layers	Procedure is limited to two structural layers and subgrade.	Combine adjacent layers of similar materials or stiffness.
	Thin stabilized layer beneath PCC surface	<ul style="list-style-type: none"> <li>• Thin layer has a minimal influence on the surface deflection.</li> <li>• Unreasonable moduli for the thin stabilized layer may result.</li> <li>• A high error level may result.</li> </ul>	<ul style="list-style-type: none"> <li>• Review results for reasonable moduli.</li> <li>• Neglect the moduli of this layer and add thickness to the underlying layer.</li> </ul>

<b>Pavement Type</b>	<b>Situation</b>	<b>Issue(s)</b>	<b>Recommendation(s)</b>
Composite	More than two structural layers	Procedure is limited to two structural layers and subgrade.	Combine adjacent layers of similar materials or stiffness.
	Bonding condition	Significant debonding/delamination between HMA surface and underlying PCC pavement can result in unreasonable modulus values and higher error levels.	<ul style="list-style-type: none"> <li>• Confirm bond condition (coring) where debonding may be an issue.</li> <li>• Model using appropriate bonding condition.</li> <li>• Convert to equivalent thickness of PCC assuming layers are unbonded.</li> </ul>
	Small PCC slab size (e.g., thin whitetopping)	Joint (or crack) discontinuity near the applied load influences results.	<ul style="list-style-type: none"> <li>• Review results for reasonable moduli.</li> <li>• Assess impact of the use of slab size adjustments on reasonableness of moduli.</li> </ul>

## CHAPTER 4. USE OF DEFLECTION DATA IN THE MEPDG

### INTRODUCTION TO MECHANISTIC-EMPIRICAL PAVEMENT DESIGN

As previously described, the mechanistic-empirical pavement design process attempts to correlate the development of critical responses in a pavement structure (such as stress, strain, or deflection) to pavement performance. There are a number of benefits to the use of a mechanistic-based pavement design procedure, including the following:

- Accommodation of changing loads and volumes.
- Quantification and better utilization of locally available materials.
- Material parameters that relate better to actual pavement behavior and performance.
- Ability to accommodate new materials.
- Accommodation of environmental and aging effects on materials.
- Improved characterization of existing pavement layer parameters.
- Improved reliability of performance prediction.

Although the concept of mechanistic-empirical pavement design has been around for decades, the recent development and release of AASHTO's MEPDG as an interim edition in 2008 has generated renewed interest as agencies contemplate the adoption of the new procedure.<sup>(2)</sup>

#### **Mechanistic-Empirical Pavement Design Principles**

There are five fundamental components that make up a mechanistic-empirical based pavement design procedure: characterization of the existing pavement structure (when applicable), traffic (loading) estimation, new material characterization, climate representation, and performance prediction. These key areas are described in the following sections.

#### *Characterization of the Existing Pavement Structure*

Characterizing the load-carrying capacity of the existing pavement structure is critical for quantifying needed rehabilitation treatments. Typically, this can be determined by identifying existing pavement distress (cracking, rutting, roughness, spalling, raveling, and delaminations), obtaining pavement cores for quantifying overall layer condition and layer thicknesses, collecting subsurface samples for subgrade strata identification and thickness determination, and performing pavement deflection testing for quantifying pavement deflection response and for computing deflection basin parameters and pavement layer moduli.

#### *Pavement Condition Evaluation*

A pavement condition evaluation is generally associated with a visual survey of the pavement surface in which pavement distresses are identified and quantified. Most highway agencies have their own standardized distress survey methods, and the FHWA's LTPP Program also has produced a distress survey manual.<sup>(64)</sup>

### *Pavement Coring*

A critical input in the backcalculation process is accurate layer thickness information. Although project documents, such as as-built drawings, are often the source of layer thickness information, coring the pavement to obtain in-place thicknesses is the preferred alternative when feasible. In addition to the layer thickness, retrieving pavement cores allows the opportunity for a visual assessment of the pavement layers, such as the following:

- Condition at the bottom of the surface layer.
- Condition of underlying stabilized layers.
- Bonding condition between pavement layers.
- Relative compaction/consolidation.
- Indication of materials-related problems.

### *Subsurface Borings*

Subsurface borings identify the type and thickness of subgrade strata and provide material samples for laboratory testing and visual soils classification. Subsurface information important to the backcalculation of deflection data also includes the depth to bedrock/stiff layer or depth of the water table, if present. Subsurface boring, typically to a depth of 3 m (10 ft), is often performed at the same locations as coring.

### *FWD Testing*

Deflection testing can be used to assess the structural condition of existing pavements, assist in the design of structural overlays, appraise seasonal variations in pavement response, assess structural variability along a project, and characterize paving layer parameters and subgrade support conditions. For rigid pavements, deflection testing can also be used to determine load transfer across joints and cracks and to detect underlying voids.

### *Other Project Testing*

A number of other specialized testing procedures can be performed during project evaluations and include ground-penetrating radar (GPR), seismic testing methods, and dynamic cone penetrometer (DCP) testing. One of the primary uses of GPR is in the determination of pavement layer thicknesses, which can be of tremendous value when backcalculating layer moduli. Examples of seismic test methods include seismic analysis of surface waves (SASW), impact echo (IE), and impulse response (IR), all of which can be used to determine layer moduli and thicknesses. DCP testing can be used to complement FWD results in the determination of unbound layer strengths.

### *Traffic Estimation*

The majority of mechanistic-empirical pavement design procedures have been developed around the use of an equivalent single-axle load (ESAL) for characterizing traffic. With the implementation of the MEPDG, traffic characterization is now based on axle load spectra,



which account for the number and magnitude of truck traffic loadings for FHWA class 4 vehicles and above.<sup>(1,65)</sup>

### *New Material Characterization*

Pavement materials are typically characterized in terms of their modulus and Poisson's ratio. In practice, assumed values for Poisson's ratio are acceptable for the majority of mechanistic-empirical pavement design procedures because the resulting designs are not overly sensitive to this input. Typically, layer moduli for new pavement materials are characterized through laboratory testing, based on historical knowledge, or based on engineering-based assumptions.

### *Climate Representation*

Because many materials (e.g., HMA and fine-grained soils) are temperature and/or moisture sensitive, the majority of mechanistic-empirical based pavement design procedures incorporate processes for including seasonal temperatures and moisture effects. In a mechanistic-empirical pavement design process, climatic effects are included to adjust layer moduli in response to seasonal effects. For example, HMA modulus values decrease during warmer temperatures but increase under colder conditions. To more accurately characterize the materials over the analysis period, these variations in layer moduli must be considered.

### *Performance Prediction*

The empirical portion of the mechanistic-empirical pavement design process includes the relationship between material parameters and the estimated number of loads to failure. This information is obtained by observing pavement performance and relating the observed failure to an initial strain (or stress) under various traffic loads.

### **Flexible Pavement Responses**

For flexible pavements, the primary means of mathematically modeling a pavement structure is layered elastic analysis. The modulus of elasticity, Poisson's ratio, and layer thickness (i.e., each layer is assumed to extend indefinitely in the horizontal direction, and the subgrade extends indefinitely downward) are used to define the parameters of each material layer. From these material parameters and loading conditions stress, strain, and pavement deflections can be computed.

Layered elastic analysis computer programs can be used to calculate the theoretical stresses, strains, and deflections anywhere in a pavement structure. Figure 47 illustrates the locations of the critical HMA pavement response locations.

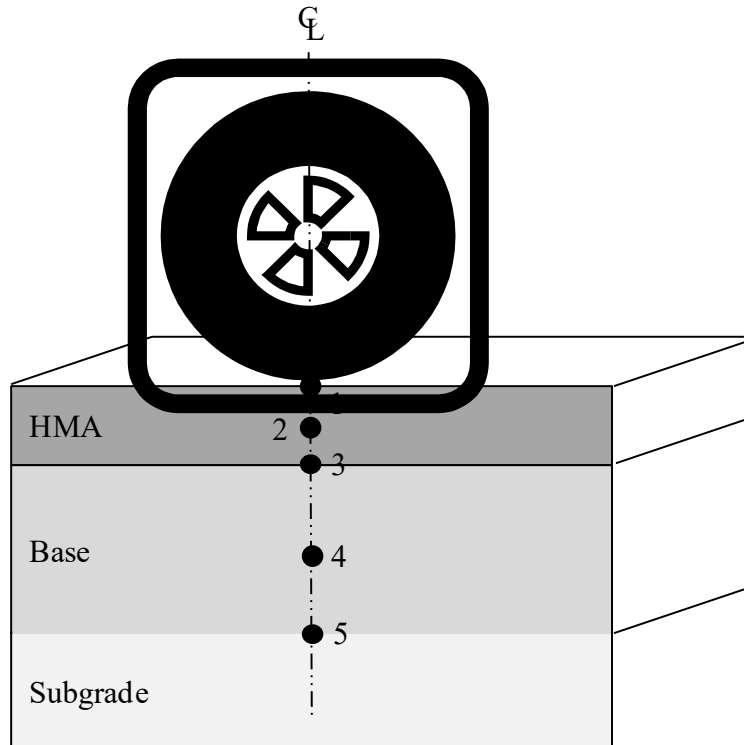

1. Tensile horizontal strain at top of HMA layer
2. Compressive vertical stress/strain within HMA layer
3. Tensile horizontal strain at bottom of HMA layer
4. Compressive vertical stress/strain within the base/subbase layers
5. Compressive vertical stress/strain at the top of the subgrade

**Figure 47. Diagram. HMA pavement response locations.**

These response locations are further described as the following:

- The horizontal tensile strain at the top and bottom of the AC layer is used in determination of fatigue cracking.
- Compressive vertical stress/strain within the HMA layer is used in the determination of rutting within the HMA layer.
- Rutting in the base/subbase layers is determined using the compressive vertical stress/strain within the base/subbase layers.
- Rutting failure in the subgrade can be predicted using the vertical compressive stress/strain at the top of the subgrade.

### **Rigid Pavement Responses**

The pavement responses critical to the performance predictions of rigid pavements include (1) deflections at the slab corners that contribute to faulting and (2) tensile stresses at midslab

that result in fatigue cracking. Factors affecting corner deflections and midslab stresses include thermal curling, moisture warping, thermal expansion and contraction, and traffic loadings.

Thermal curling is the result of differences in temperature between the top and the bottom of the slab and the restriction to these changes caused by the weight of the slab itself (see figure 48). Moisture warping, on the other hand, develops owing to differences in the moisture content between the top and bottom of the slab. Curling and warping in the slab influence both the midslab stresses and the corner deflections. The magnitude of the midslab stresses is also influenced by restraint forces caused by friction at the slab/base interface as the slab expands and contracts under changing temperature conditions.

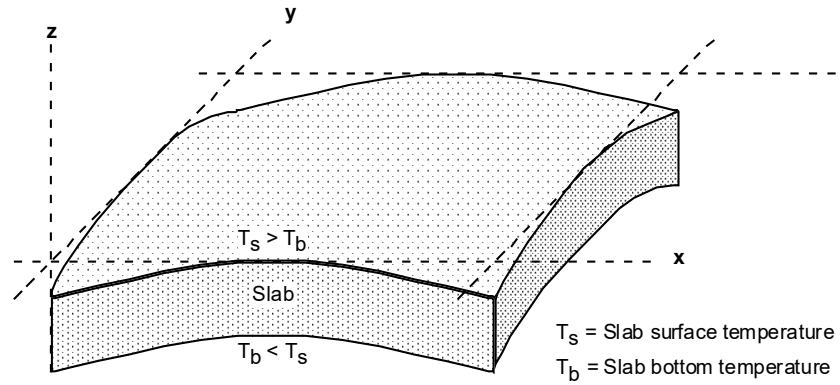

(a) Day (slab surface temp > bottom temp)

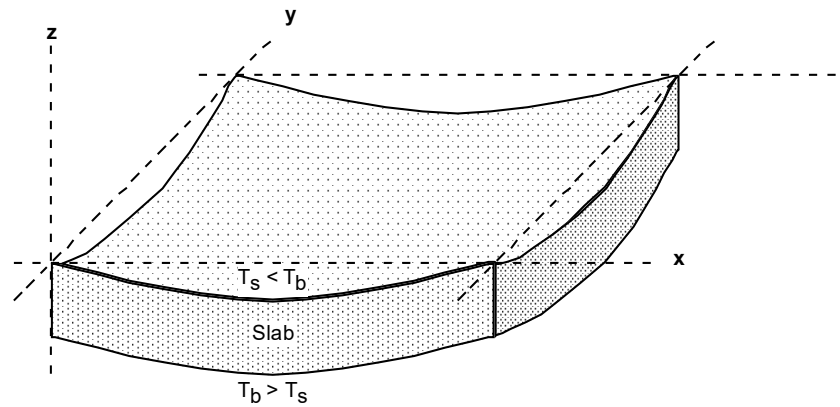

(b) Night (slab bottom temp > surface temp)

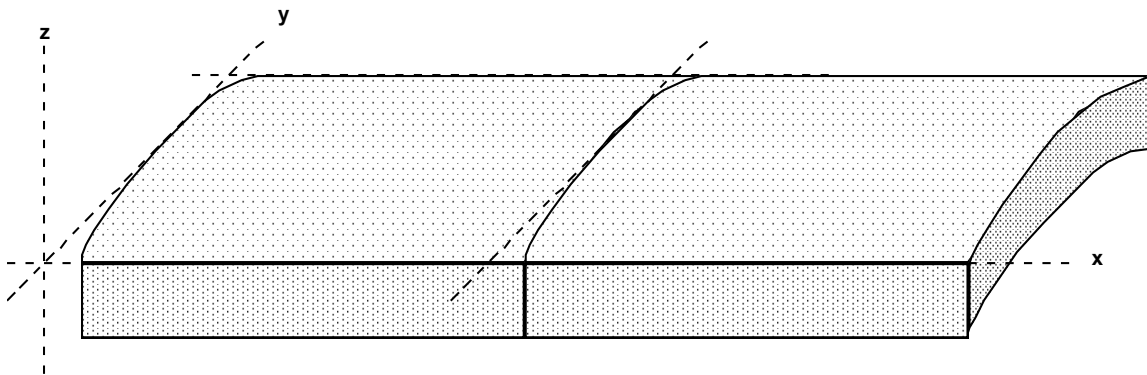

(c) Constrained Transverse Joints (High slab mean temp., slab surface temp > bottom temp.)

©Washington State Department of Transportation

**Figure 48. Diagrams. Thermal curling stress for (a) day (b) night, and (c) constrained transverse joints.<sup>(27)</sup>**

The final factor affecting slab responses is the applied vehicle loads. While the critical load location for faulting predictions is at the corner of the slab, the critical load location for fatigue cracking is a function of the shape of the slab at the time of loading. The slab is susceptible to top-down cracking when there is upward curvature and the axles are spaced such that the approach and leave joints are being loaded simultaneously. Damage related to bottom-up cracking occurs when the axle is located at midslab and when the slab is flat or upward curvature is present. These critical loading conditions are depicted in figure 49.

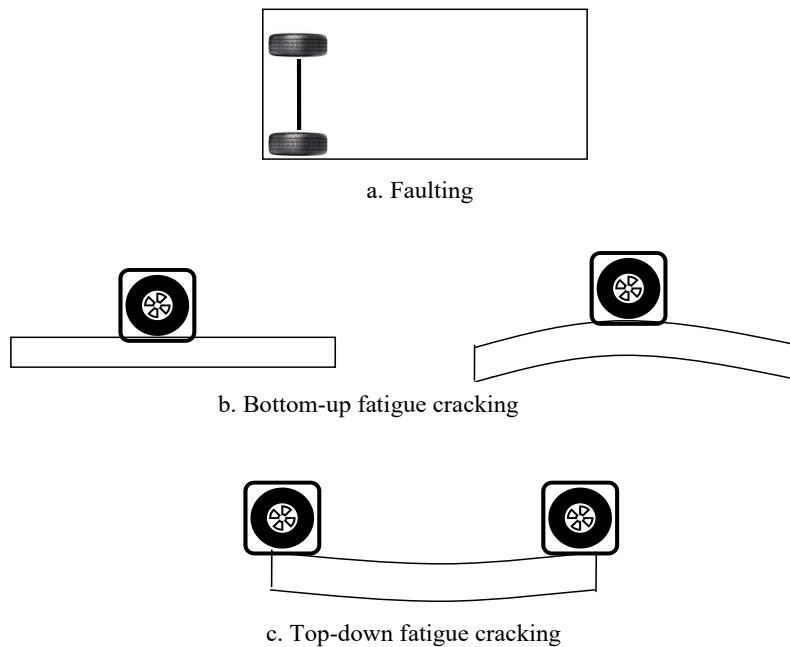

**Figure 49. Diagrams. Critical loading conditions: (a) faulting, (b) bottom-up fatigue cracking, and (c) top-down fatigue cracking.**

## SELECTION OF DEFLECTION-BASED INPUTS FOR THE MEPDG

As with the traffic and environmental design inputs in the MEPDG, the material inputs are also based on a hierarchical level. One advantage of this approach is that it allows flexibility in selecting an engineering approach based on project size, cost, and importance.<sup>(1)</sup> The hierarchical levels for characterizing materials, in general, include the following:

- **Level 1:** Determination of material properties/parameters using both field and laboratory testing.
- **Level 2:** Estimation of material parameters using correlations with other material properties.
- **Level 3:** Estimation of material parameters based on experience with little or no testing.

For a given project, the designer may select a mix of hierarchical levels. The mix of hierarchical levels is possible because the MEPDG uses the same computational algorithm for estimating damage, regardless of the input design level.

In the MEPDG, deflection-based input data are primarily for the level 1 evaluation and generally consist only of the layer parameters; most of the other uses of deflection data are not incorporated into the design procedure, at least not directly.<sup>(1)</sup> In addition, the backcalculation results are not necessarily used directly as inputs in the MEPDG procedures but often require the application of adjustment factors to correspond to the laboratory-based values that were used in the development of the MEPDG performance models.

## PROJECT EVALUATION IN THE MEPDG

The MEPDG provides information regarding the type of activities that should be conducted as part of a project evaluation; a general discussion is provided in section 10 of the AASHTO *Mechanistic-Empirical Pavement Design Guide—A Manual of Practice (Interim Edition)*, and a more detailed discussion for the different pavement types is provided in section 3.<sup>(2)</sup> Table 27 summarizes the input data for the three data levels. The discussion in the following subsections presents a brief summary of the primary evaluation activities and how they relate to interpreting deflection data.

**Table 27. Definition of input levels for pavement evaluation.<sup>(1)</sup>**

Features	Factor	Data Level 1	Data Level 2	Data Level 3
Structural adequacy	Load-related distress	Perform 50- to 100-percent visual survey of entire project	Perform 10- to 50-percent visual survey of entire project	Perform windshield survey of entire project
	<ul style="list-style-type: none"> <li>• Deflection testing</li> <li>• GPR testing</li> <li>• Profile testing (IRI)</li> </ul>	Test every 150 m (500 ft) or less over the entire project	Test every 150 m (500 ft) or more over the entire project	Use historic data or perform limited testing at selected locations
	Coring, DCP	Perform at 600 m (2,000 ft) or less	Perform at 600 m (2,000 ft) or greater	Use historic data or perform limited testing at selected locations
	Maintenance data	Use historic data and visual survey	Use historic data	Use historic data
Functional evaluation	Profile testing (IRI)	Test along entire project	Test along selected sample units of project	Use historic data
	Friction testing (friction number)	Test along entire project	Test along selected sample units of project	Use historic data

<b>Features</b>	<b>Factor</b>	<b>Data Level 1</b>	<b>Data Level 2</b>	<b>Data Level 3</b>
Surface drainage	Climate data	See NCHRP 1-37A Research Report, chapter 3, part 2 <sup>(1)</sup>		
	Moisture-related distress	Perform 100-percent survey of entire project	Perform 100-percent survey of sample area along project	Perform windshield survey of entire project
	Signs of moisture-accelerated damage	Perform 100-percent survey of entire project	Perform 100-percent survey of sample area along project	Perform windshield survey of entire project
	Condition of subsurface drainage facilities	Perform 100-percent survey of entire project	Perform 100-percent survey of sample area along project	Perform windshield survey of entire project
	Condition of surface drainage facilities	Perform 100-percent survey of entire project	Perform 100-percent survey of sample area along project	Perform windshield survey of entire project
Materials durability	Durability-related surface distress	Perform 100-percent visual survey of entire project	Perform 100-percent visual survey of sample area along project	Perform windshield survey of entire project
	Base condition (erosion, stripping) or contamination	Test every 15 m (50 ft) along project	Test every 150 m (500 ft) along project	Use historic data or limited testing at selected locations
Shoulder	Surface condition (distress and joint)	Perform 100-percent visual survey of entire project	Perform 100-percent visual survey of sample area along project	Perform windshield survey of entire project
Variability along project	Identification of areas of likely variability and their condition	Perform 100-percent survey <sup>1</sup> of entire project	Perform 100-percent survey <sup>1</sup> of sample area along project	Perform windshield survey <sup>1</sup> of entire project
Miscellaneous	PCC joint condition	Perform 100-percent visual survey of entire project	Perform 100-percent visual survey of sample area along project	Perform windshield survey of entire project
	Traffic capacity and geometrics	Perform 100-percent visual survey of entire project	Perform 100-percent visual survey of sample area along project	Perform windshield survey of entire project
Constraints	Are detours available?	Perform 100-percent visual survey of entire project	Perform 100-percent visual survey of sample area along project	Perform windshield survey of entire project
	Should construction be accomplished under traffic?	Perform 100-percent visual survey of entire project	Perform 100-percent visual survey of sample area along project	Perform windshield survey of entire project
	Bridge clearance problems	Perform 100-percent visual survey of all bridges in entire project	Perform 100-percent visual survey of sample area along project	Perform windshield survey of entire project

Features	Factor	Data Level 1	Data Level 2	Data Level 3
	Lateral obstruction problems	Perform 100-percent visual survey of entire project	Perform 100-percent visual survey of sample area along project	Perform windshield survey of entire project
	Utilities problems	Perform 100-percent visual survey of entire project	Perform 100-percent visual survey of sample area along project	Perform windshield survey of entire project

<sup>1</sup>All relevant surveys (e.g., visual, drainage). Levels 1 and 2 are typically benchmark data, while level 3 consists of a limited form of benchmark data obtained from windshield surveys and historic data.

IRI = International Roughness Index.

FN = friction number.

### Pavement Condition Evaluation

A pavement condition evaluation is generally associated with a visual survey of the pavement surface in which pavement distresses are identified and quantified. Pavement distress surveys can be performed in conjunction with FWD testing to identify areas where more intensive testing may be beneficial and can also prove useful in evaluating variations in the deflection testing results (e.g., an area of higher than average deflections may correspond to an area with more distress). In addition, surface distress data are used to determine several qualitative adjustments to material parameters for rehabilitation design.

Although distress data are used in establishing a number of inputs in the MEPDG, they are not significantly used in level 1 and deflection data analysis. However, the distress survey data are used for level 3 rehabilitation design to determine the adjustment factor applied to the moduli for chemically stabilized (see table 28), HMA (see table 29), and PCC (see table 30) layers.

**Table 28. Damage of existing chemically stabilized modulus based on pavement condition.<sup>(1)</sup>**

Category	Damage
Excellent	0.00–0.20
Good	0.20–0.40
Fair	0.40–0.80
Poor	0.80–1.20

**Table 29. Damage of existing HMA modulus based on pavement condition.<sup>(1)</sup>**

Category	Damage
Excellent	0.00–0.20
Good	0.20–0.40
Fair	0.40–0.80
Poor	0.80–1.20



**Table 30. Description of existing PCC pavement condition.<sup>(1)</sup>**

Existing Pavement Type	Structural Condition		
	Good	Moderate	Severe
JPCP (percent of slabs cracked) <sup>1</sup>	< 10	10 to 50	> 50 or crack and seat
JRCP (percent area deteriorated) <sup>2</sup>	< 5	5 to 25	> 25 or break and seat
CRCP (percent area deteriorated) <sup>3</sup>	< 3	3 to 10	> 10

<sup>1</sup> Percent slabs cracked with all severities and types of cracks plus any repairs.

<sup>2</sup> Percent area, including repairs or patches, deteriorated joints, and deteriorated cracks (deteriorated joints and cracks converted to repair areas).

<sup>3</sup> Percent area includes repairs, patches, and localized failures and punchouts converted to repair areas.

JRCP = Jointed reinforced concrete pavement.

### **Pavement Coring**

A critical input in the backcalculation process is accurate layer thickness information. Although project documents, such as as-built drawings, are often the source of layer thickness information, coring the pavement to obtain in-place thicknesses is often the preferred alternative. As indicated in ASTM D5858, “Standard Guide for Calculating In Situ Equivalent Elastic Moduli of Pavement Materials Using Layered Elastic Theory,” bound pavement layer thicknesses should be reported to the nearest 5 mm (0.2 inches), and unbound pavement layer thicknesses should be reported to the nearest 25.4 mm (1.0 inch).<sup>(66)</sup>

The number and location of cores is project specific and depends on several factors. Table 27 indicates that cores should be retrieved at intervals less than 600 m (2,000 ft) for the level 1 evaluation and at intervals greater than 600 m (2,000 ft) for the level 2 evaluation. Because of the differences in pavement cross section, pavement materials, construction dates, traffic levels, and many other variables, projects will often be split into multiple sections for analysis. As a minimum, it is generally recommended to retrieve at least one core sample from each analysis section.

### **Subsurface Boring**

Subsurface borings identify the thickness of subgrade strata and provide material samples for laboratory testing (e.g., depth and thickness of subgrade soils, depth to water table or wet layers, depth to stiff layer, moisture content, density, and resilient modulus) and soil classification. Subsurface information important to the backcalculation of deflection data includes the depth to the rigid layer and the depth to the water table, if present. As a matter of convenience, subsurface borings are commonly performed at the same locations as coring. However, borings are also commonly conducted in unpaved areas adjacent to the pavement to avoid traffic closures; these locations may not provide information as accurate as would be obtained from directly under the pavement.

### **Laboratory Testing**

The MEPDG requires design inputs from several laboratory tests, including testing to adjust input values derived from backcalculation.<sup>(1)</sup> Laboratory testing of the existing paving and subgrade materials is also a means to check or validate backcalculation results, which is highly recommended. Although the details of the tests themselves are not discussed here, the following

list of the general layer parameters (or those required by the MEPDG) can be obtained from material samples:

- **Existing HMA pavement:** Unit weight, dynamic modulus, volumetric characteristics (air voids, asphalt content, gradation, and asphalt viscosity).
- **Existing PCC pavement:** Unit weight, elastic modulus, compressive or indirect tensile strength, and coefficient of thermal expansion.
- **Existing stabilized layers:** Elastic or resilient modulus, as appropriate for material.
- **Unbound base/subgrade:** Gradation, Atterberg limits, dry density, moisture content, and resilient modulus.

In the MEPDG, level 1 evaluation of JPCP recommends cutting and testing prismatic beams from pavement, while compression strength testing of cores is recommended for level 2.<sup>(1)</sup> For CRCP evaluation, the MEPDG recommends split tensile strength testing. Retrieving beam samples is often cumbersome and costly. In addition, split tensile testing has often been preferred for correlating PCC flexural strength from core specimens; therefore, it is also recommended for validating backcalculation results.

### **Other Project Testing**

As described previously, other testing procedures often employed in a project evaluation include GPR, seismic testing methods, and DCP testing. GPR is becoming a more common test method in project evaluations and, as discussed in the MEPDG, its primary use in conjunction with deflection testing is in the determination of pavement layer thicknesses.<sup>(1)</sup> Unlike pavement coring, which provides thickness information for a relatively limited number of locations, GPR can produce continuous thickness data over the length of the project, including the exact location of the FWD test locations. The determination of pavement thickness using GPR has been reported to be accurate within a range 3 to 5 percent for new asphalt, 5 to 10 percent for existing asphalt and for concrete layers, and 8 to 15 percent for a granular base layer.<sup>(67)</sup>

Seismic methods, such as SASW, IE, and IR, have been used to determine layer moduli and thicknesses. Use of these methods is growing but they are not yet as commonly used as some of the other field-testing procedures.

DCP testing is an acceptable input for the MEPDG for levels 2 and 3 with correlations to the necessary design inputs.<sup>(1)</sup> While it is not directly required for interpretation of backcalculation results, it can be used to help validate backcalculation and laboratory test results because it provides an indicator of the relative strength of unbound bases and subgrade materials (typically in terms of the California Bearing Ratio, which can be correlated to resilient modulus).

### **MEPDG Flexible Pavement Inputs**

The required material parameters for HMA pavements in the MEPDG relevant to the use of FWD data and backcalculation results are the following:<sup>(1)</sup>

- Time-temperature dependent dynamic modulus,  $E^*$ , for the HMA layer(s).
- Resilient moduli for the unbound base/subbase and subgrade materials.
- Elastic modulus of the bedrock layer, if present.

The MEPDG also provides an option for considering nonlinear material parameters for the unbound layers for level 1 analysis.<sup>(1)</sup> However, the performance models used in the software have not been calibrated for nonlinear conditions, so this option is not considered further.

### HMA Materials

The level 1 design analysis in the MEPDG software uses an  $E^*$  (dynamic modulus) master curve and therefore does not accept a constant modulus value for the HMA layer(s).<sup>(1)</sup> This is necessary because the program calculates different HMA moduli for the different sublayers comprising the HMA layer(s) as a function of depth, speed, and axle type, as explained in appendix CC of the MEPDG.<sup>(1)</sup> However, the current MEPDG procedure (level 1) does allow static backcalculation of layer moduli for the rehabilitation of existing HMA pavements, which leads to constant backcalculated modulus for all layers, including the HMA layer. In this case, to maintain compatibility of the backcalculated layer moduli with the forward analysis in the software, the MEPDG procedure adjusts the HMA dynamic modulus (predicted  $E^*$  based on input mixture properties) using the damage factor,  $d_j$ , which is the ratio of backcalculated HMA modulus to the predicted  $E^*$  value using the Witczak equation. This effectively shifts the undamaged master curve down while essentially maintaining the variation with frequency as predicted by the Witczak equation. The procedure also calls for adjusting the master curve using the aged viscosity value in the predictive  $E^*$  equation, which shifts the master curve upward; however, this upward shift is negligible compared with the downward shift using the backcalculated modulus for the damaged HMA layer,  $E_{dam}$ .

The procedure for determining the field-damaged dynamic modulus master curve is illustrated in figure 50.<sup>(1)</sup>

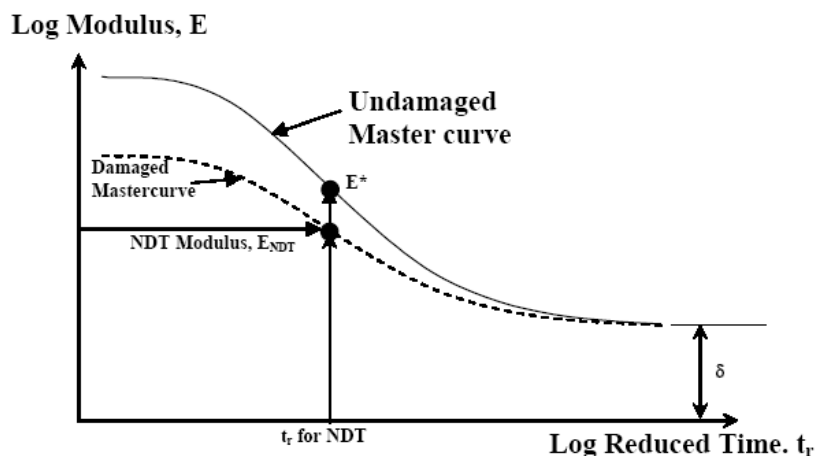

©AASHTO. Used by permission.

**Figure 50. Diagram. Illustration of HMA modulus correction.<sup>(1)</sup>**

The following steps summarize the procedure:

1. Conduct FWD testing in the outer wheelpath over the project to be rehabilitated (include cracked and uncracked areas); calculate the mean backcalculated HMA modulus,  $E_{FWD}^*$  (combining layers with similar materials); record the HMA layer temperature at the time of testing; and determine the layer thickness along the project using coring or GPR.
2. Determine the mix volumetric parameters (air void content, asphalt content, and gradation), asphalt viscosity parameters (regression intercept ( $A$ ), and regression slope of viscosity temperature susceptibility (VTS)) from field cores; follow the same procedure for determining binder viscosity-temperature properties as for a new or reconstruction design.
3. Develop an undamaged dynamic modulus master curve using the data from step 2 at the same temperature recorded in the field and at an equivalent frequency corresponding to the FWD pulse duration. The equation for the undamaged dynamic modulus is shown in figure 51.

$$\log(E^*) = \delta + \frac{\alpha}{1 + e^{\beta + \gamma \log(t_r)}}$$

**Figure 51. Equation. Undamaged dynamic modulus.**

Where:

$E^*$  = Dynamic modulus (MPa (lbf/inch<sup>2</sup>)).

$\delta$ ,  $\alpha$  = Fitting parameters that are dependent on aggregate gradation, binder content, and air void content;  $\delta$  represents the minimum value of  $E^*$  and  $\delta + \alpha$  represents the maximum value of  $E^*$ .

$\beta$  and  $\gamma$  = Regression parameters that are dependent on the characteristics of the asphalt binder and the magnitude of  $\delta$ ,  $\alpha$ .

$t_r$  = Time of loading at reference temperature (s).

4. Estimate the fatigue damage in the existing HMA layer,  $d_{ac}$ , using the equation in figure 52. Note that the value of  $E^*$  to be used in this equation should be selected from the undamaged master curve obtained in step 3 at a reduced frequency (or time) that represents FWD test temperature and frequency.\*

$$\log(d_{ac}) = 0.2 \left[ \ln \left( \frac{E^* - E_{FWD}}{E_{FWD} - 10^\delta} \right) + 0.3 \right]^*$$

**Figure 52. Equation. Estimate of damage ( $d_{ac}$ ).\***

Where:

$E_{FWD}$  = backcalculated HMA modulus from FWD testing, lbf/in<sup>2</sup> from step 1.\*

$\delta$  = Fitting parameters that are dependent on aggregate gradation, binder content, and air void content; represents the minimum value of  $E^*$ .

$E^*$  = Undamaged modulus, lbf/inch<sup>2</sup> from step 3.

- Keeping  $d_{ac}$  at the constant value as estimated from step 4, determine the damaged modulus master curve,  $E^*_{dam}$  of the existing damaged HMA layer from the equation shown in figure 53.\*

$$E^*_{dam} = 10^\delta + \frac{E^* - 10^\delta}{1 + e^{-0.3 + 5 \times \log(d_{ac})}} *$$

**Figure 53. Equation. Determination of damaged modulus.\***

Where:

$E^*_{dam}$  = Damaged modulus, lbf/in<sup>2</sup>.\*

- It is also important to consider the reduced time representative of the nondestructive testing (NDT) loading and viscosity temperature at the time of the NDT. This is incorporated into the determination of the field master curve using the equations shown in figure 54.

$$\begin{aligned} \log(t_r) &= \log(t) - 1.255882[\log(\eta) - \log(\eta_{Tr})] \\ \log \log \eta &= A + VTS \log T_r \end{aligned}$$

**Figure 54. Equation. Determination of the field master curve.**

Where:

$t_r$  = Reduced time for NDT loading (s).

$t$  = NDT loading time (s).

$\eta$  = Binder viscosity at the NDT temperature.

$\eta_{Tr}$  = Binder viscosity at 21°C (70 °F).

$\eta$  = Binder viscosity.

$A$  = Viscosity temperature susceptibility intercept.

$VTS$  = Viscosity temperature susceptibility slope.

$T_r$  = Temperature (° Rankine).

For levels 2 and 3 analyses, no FWD testing is required. The level 2 procedure is similar to the level 1 procedure in that field cores are used to obtain the undamaged modulus; however, estimates for fatigue damage of the existing asphalt layer are determined through a detailed pavement condition survey and the calibrated MEPDG distress models. For example, the equation in figure 55 illustrates the distress model for top down cracking.

$$FC_{top} = \left( \frac{C_4}{1 + e^{(c_1 - c_2 * \log 10(damage))}} \right) * 10.56$$

**Figure 55. Equation. Distress model for top-down cracking.**

Where:

$FC_{top}$  = Percent top-down cracking in the asphalt layer.

$C_1, C_2, C_4$  = Regression coefficients.

$damage$  = Damage in the HMA layer.

The equation in figure 55 is solved for the damage term, which is then used in the equation in figure 52 to determine the damaged modulus master curve.

For the level 3 procedure, no coring or testing is required; instead typical estimates of HMA mix parameters (typical volumetric and binder properties) are input, and the program calculates the undamaged master curve. The damage factor is estimated from general condition data previously presented in table 29, and the damaged modulus master curve is then determined using the equation in figure 52.

### Chemically Stabilized Materials

Similar to unbound materials, only level 1 analysis calls for FWD testing in rehabilitation and reconstruction designs. The moduli for any chemically stabilized layer (including lean concrete and cement stabilized base, as well as lime/cement/fly ash stabilized soils) can be either determined in the laboratory or backcalculated using standard backcalculation procedures. Layer thicknesses can be obtained by coring or using NDT techniques such as the GPR. The MEPDG recommends performing limited testing on cored lime stabilized soil specimens to verify/confirm the backcalculated values and notes that backcalculation of modulus values for layers less than 150 mm (6 inches) thick located below other paving layers may be problematic, thus requiring laboratory testing.<sup>(1)</sup>

For a level 1 characterization, the modulus at the current damage level,  $E_{CTB}$ , and the intact modulus are used to determine a damage factor. The modulus at the current damage level is the value obtained from backcalculation. The intact modulus is obtained from the compressive strength of intact cores removed from undamaged areas of the pavement and is used to estimate the initial intact modulus,  $E_{max}$  (described in part 2, chapter 2 of the MEPDG).<sup>(1)</sup> With  $E_{CTB}$  and  $E_{max}$  known, the current damage level can be determined, as illustrated in figure 56.

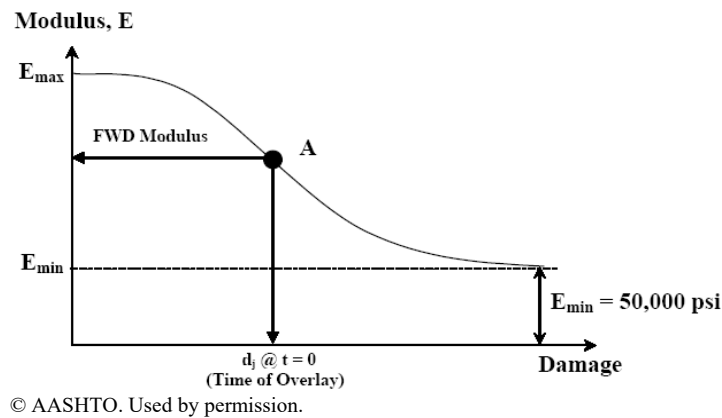

**Figure 56. Graph. Illustration of estimating damage factor using backcalculated base moduli.<sup>(1)</sup>**

The backcalculated modulus is used as the modulus at the beginning of the overlay analysis and further reduced based on the condition of the stabilized layer and pavement surface (as shown by the equation in figure 57).

$$C_{CTB} = \left( \frac{100(C_s)}{RC} \right)$$

**Figure 57. Equation. Reduction of backcalculated modulus based on observed conditions.**

Where:

$C_{CTB}$  = Percent alligator cracking in the chemically stabilized layer.

$C_s$  = Percent alligator cracking observed at the pavement surface.

$RC$  = Percent of cracks reflected, percent ( $RC = \frac{100}{1+e^{a+bt}}$ , where  $t$  = time (yr) and  $a$  and  $b$  = fitting parameters).

For level 2 analysis, correlations with strength test data (see table 11-6, AASHTO *Mechanistic-Empirical Design Guide—A Manual of Practice (Interim Edition)*) are used.<sup>(2)</sup> For level 3, the MEPDG calls for estimating the moduli based on experience or historical records and lists typical modulus values. The MEPDG also notes that semirigid cementitious stabilized materials are more prone to deterioration as a result of repeated traffic loads when used in HMA pavements and suggests typical values (see table 31) for such deteriorated materials.

**Table 31. Recommended input values for elastic or resilient modulus of chemically stabilized materials.<sup>(2)</sup>**

Material	Elastic or Resilient Modulus (MPa (lbf/inch <sup>2</sup> ))
Lean concrete, $E$	13,800 (2 million)
Lime-cement-fly ash, $E$	10,300 (1.5 million)
Cement stabilized aggregate, $E$	6,900 (1 million)
Open graded cement stabilized aggregate, $E$	5,200 (750,000)
Soil cement, $E$	3,500 (500,000)
Lime stabilized soils, $M_R$	310 (45,000)

### Unbound Materials

In the case of unbound materials, FWD testing in rehabilitation and reconstruction designs is required only in a level 1 analysis. The modulus for each unbound layer (including the subgrade) can be either determined in the laboratory using cyclic triaxial tests or backcalculated using standard backcalculation procedures. As discussed previously, while the MEPDG does allow for the generalized nonlinear, stress-dependent model in the design procedure, this approach is not recommended at the time of this report because the performance models in the software have not been calibrated for nonlinear conditions; therefore, the option of backcalculating the  $k_1$ ,  $k_2$ , and  $k_3$  parameters in the nonlinear model is not discussed. Consequently, the discussion only includes the backcalculation and use of effective moduli that account for any stress sensitivity, cracks, or any other anomalies in any layer within the existing pavement.

As with the HMA modulus, the backcalculated values must be adjusted to correspond with laboratory-obtained values, on which the MEPDG forward designs are based. Although there is continued debate within the pavement community on appropriate correlation values, the existing

correlations are recommended until more definitive guidance can be established. Part 3 of chapter 6, of the MEPDG indicates that adjustment factors of 0.40 for subgrade soils and 0.67 for granular bases and subbases have been used to correlate backcalculated moduli.<sup>(1)</sup> The MEPDG also provides additional backcalculation adjustment guidance for different layers, as summarized in table 32.

**Table 32. Summary of backcalculated-to-laboratory modulus ratios.<sup>(1)</sup>**

Layer Type	Layer Location	Mean $M_R/E_R$ Ratio
Unbound granular base and subbase layers	Granular base/subbase between two stabilized layers (cementitious or asphalt stabilized materials).	1.43
	Granular base/subbase under a PCC layer.	1.32
	Granular base/subbase under an HMA surface or base layer.	0.62
Embankment and subgrade soils	Embankment or subgrade soil below a stabilized subbase layer or stabilized soil.	0.75
	Embankment or subgrade soil below a flexible or rigid pavement without a granular base/subbase layer.	0.52
	Embankment or subgrade soil below a flexible or rigid pavement with a granular base or subbase layer.	0.35

$E_R$  = Backcalculated elastic modulus.

$M_R$  = Elastic modulus of the in-place materials determined from laboratory repeated load resilient modulus test.

For level 2 analysis, correlations with strength test data are used. For level 3, the guide lists typical modulus values based on soil classification but warns that they are approximate and strongly recommends some form of field testing.<sup>(1)</sup>

### Feasibility of Using Dynamic Backcalculation for Future Versions of the MEPDG

Ideally, it should be possible to determine a curve of HMA layer modulus as a function of frequency using a (dynamic) frequency-based backcalculation algorithm. This would give a more direct estimation of the HMA layer modulus with frequency from actual field conditions as opposed to relying on a laboratory-derived curve such as the Witczak equation. However, care should be taken in interpreting and using such data with the existing MEPDG performance predictions, because these data have been calibrated using laboratory-derived moduli. Also, recent analyses show that while dynamic backcalculation methods can backcalculate layer moduli and thicknesses accurately from synthetically generated FWD data for pavement systems with three or more layers, some serious challenges arise when using field data.<sup>(38)</sup> The frequency-domain method can lead to large errors if the measured FWD records are truncated before the motions fully decay in time, which leads to corruption of the frequency content of the signal; the only remedy is to match the sensor time histories in the time domain. However, FWD-measured time histories may not be accurate enough in this regard, because data beyond the first peak include an unknown amount of signal drift coming from the double integration of acceleration measurements (or the single integration of velocity measurements) to obtain deflections.

Dynamic, time-domain backcalculation algorithms present another challenge in that they cannot directly determine the HMA modulus as a function of frequency. Such algorithms either assume



a constant HMA modulus under linear elastic behavior (similar to many static backcalculation procedures) or use a prescribed function of the HMA layer modulus with frequency (e.g., linear relation in the log-log space).

## **RIGID PAVEMENT INPUTS IN THE MEPDG**

The input parameters needed for the design of an overlay on top of a PCC pavement using the MEPDG that can be extracted from FWD data include the following:

- Elastic modulus of the existing PCC and base layers.
- Subgrade  $k$ -value.
- PCC flexural strength (based on the backcalculated PCC elastic modulus).

The moduli for each layer can also be backcalculated using layered elastic theory, but as previously discussed, it is better to define the stiffness of the lower layers with the backcalculated  $k$ -value. Although not a direct input into the MEPDG, the deflection data should also be used to identify any voids present beneath the slab because the design analysis assumes that any voids will be addressed before the overlay is placed. Recommendations to consider when determining these inputs, based on FWD data, are provided in the following sections.

### **Effective $k$ -Value**

The ideal method for characterizing the subgrade in the MEPDG is by backcalculating the effective  $k$ -value, which represents the stiffness of all layers beneath the base. It is important to note that the input  $k$ -value in the MEPDG for rehabilitation design is the backcalculated dynamic value, not the typically corrected static  $k$ -value. (Note that traditionally, an effective  $k$ -value refers to a  $k$ -value that is adjusted for seasonal effects, and the composite  $k$ -value refers to the composite stiffness of all layers beneath the slab.) In addition to the dynamic  $k$ -value, the MEPDG also requires that the moduli of each layer be provided; this is because the  $k$ -values are used for PCC stress calculations and the layer modulus values are used for calculation of the strains in an HMA overlay (placed as a rehabilitation treatment).<sup>(1)</sup>

When the layer moduli are used to define the characteristics of the pavement structure in the MEPDG for new PCC pavement designs, the software uses an internal conversion process to determine an effective  $k$ -value. The MEPDG documentation defines an effective  $k$ -value as the composite stiffness of all layers beneath the base, as shown in figure 58. The process involves backcalculating the effective  $k$ -value from the theoretical deflection basin produced using the elastic layer program JULEA. However, in this process, the subgrade resilient modulus is adjusted to reflect the lower deviator stress under PCC pavements (compared with that used in laboratory resilient modulus testing) before generating the deflection basin. Therefore, the subgrade resilient modulus backcalculated from FWD testing cannot be used directly in the MEPDG for PCC or composite pavements because the backcalculated moduli values reflect the state of stress under PCC pavements and not under laboratory testing conditions. While adjustments could be made to obtain “laboratory” resilient moduli, the  $k$ -value directly backcalculated from the FWD data best represents the true foundation stiffness. Therefore, backcalculation procedures that directly produce  $k$ -values are recommended for PCC pavements.

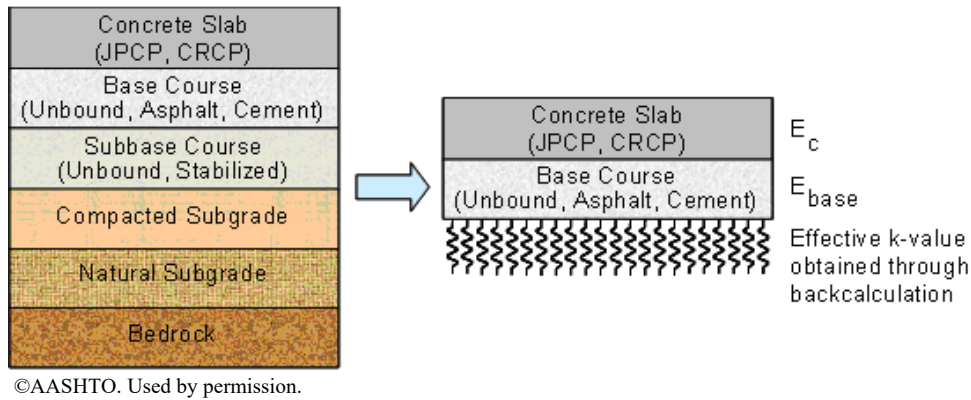

**Figure 58. Diagram. Illustration of the  $E$ -to- $k$  conversion process incorporated in the MEPDG.<sup>(1)</sup>**

The dynamic  $k$ -value for rehabilitated pavements can be backcalculated from PCC surface deflections.<sup>(2)</sup> Therefore, the result is an effective dynamic  $k$ -value that represents the compressibility of all layers beneath the PCC slab, in which the PCC slab is defined as follows based on the proposed rehabilitation strategy:

- For unbonded JPCP/CRCP over an existing rigid pavement, the PCC slab is defined as the PCC overlay.
- For bonded PCC over JPCP/CRCP, the PCC slab is the composite of the overlay and existing PCC layer.

In the case of an HMA overlay over JPCP, the MEPDG documentation (part 3 of chapter 6) states that the HMA/JPCP structure would be converted to an equivalent structure that consists of an equivalent slab and a foundation.<sup>(1)</sup> The stiffness of the equivalent slab is determined by the stiffness of the HMA overlay, the existing PCC layer, and the base layer. The effective dynamic  $k$ -value is used to represent the compressibility of the subgrade layer only.

To better illustrate these definitions, the research team generated three figures—one for each overlay rehabilitation type. Figure 59 through figure 61 present how the actual structure of the rehabilitated pavement is converted into an equivalent layered system to calculate the effective dynamic  $k$ -value for HMA, unbonded PCC, and bonded PCC overlays, respectively. As shown in these figures, the meaning of the effective dynamic  $k$ -value varies with the type of rehabilitation, as described in the following subsections.

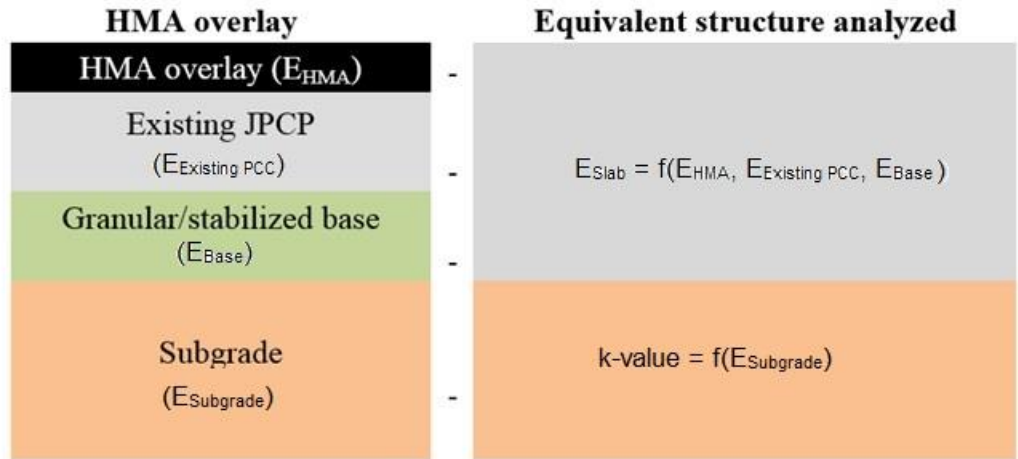

Figure 59. Diagram. Transforming the actual pavement structure into an equivalent structure for an HMA layer over a PCC slab.

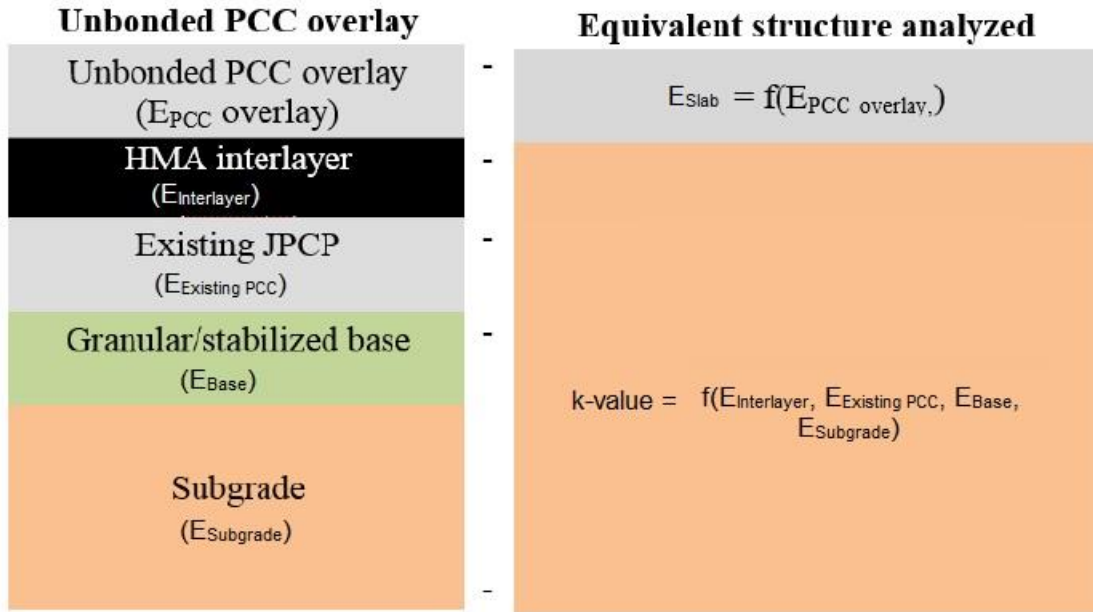
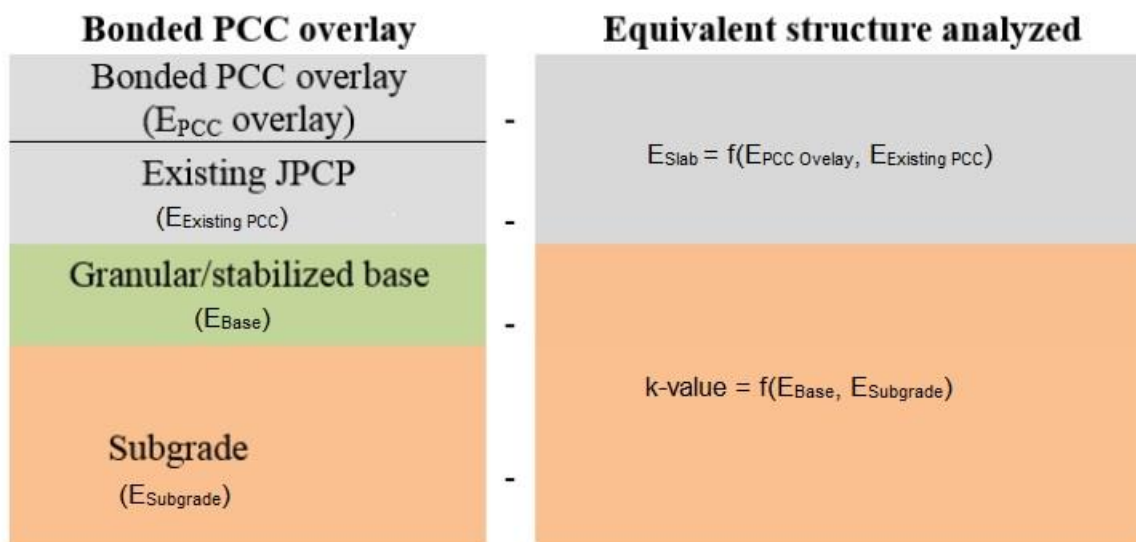

Figure 60. Diagram. Transforming the actual pavement structure into an equivalent structure for an unbonded JPCP/CRCP over a PCC slab.



**Figure 61. Diagram. Transforming the actual pavement structure into an equivalent structure for a bonded JPCP/CRCP over a PCC slab.**

### *HMA Overlay*

The  $k$ -value input does not appear to be used within the MEPDG for HMA overlay design; therefore, it is suggested that the  $k$ -value not be entered at this time.

### *Bonded PCC Overlay*

For bonded PCC overlays, the MEPDG  $k$ -value input represents the composite stiffness of all layers below the base. The backcalculated  $k$ -value can be used directly to define this input if the existing slab is on a stabilized base. However, in reality, the backcalculated  $k$ -value represents the stiffness of the base as well as all other underlying layers if the base is not stabilized. The backcalculated  $k$ -value can be adjusted to negate the stiffness of the base by using the method proposed in the Portland Cement Association (PCA) design guide, which combines the stiffness of the subgrade and the subbase.<sup>(68)</sup>

The elastic modulus of the base must also be established for the bonded overlay. It is suggested that a typical value be used if the base is unstabilized. If the base is stabilized, then the method presented by Ioannides and Khazanovich can be used to modify the backcalculated elastic modulus of the PCC and used to estimate the base layer modulus.<sup>(69)</sup>

### *Unbonded PCC Overlay*

As shown in figure 57, the  $k$ -value defined by the MEPDG consists of the composite stiffness of all layers below the HMA debonding layer.<sup>(1)</sup> At the time of this report, it was not possible to backcalculate a  $k$ -value representing the combined the stiffness of the complete pavement structure, including the slab. It was found that for the limited cases evaluated, reasonable overlay thicknesses were achieved when the  $k$ -value representing the stiffness for all layers beneath the

slab was used, as described for the bonded overlay design. Therefore, this approach is suggested until more definitive guidance can be provided.

Finally, it is important to correctly enter in the other material characterization properties, such as the gradations of these layers, because this information is used along with EICM to estimate the seasonal effects on the  $k$ -value. When entering the  $k$ -value, the designer must also enter the month in which the  $k$ -value was measured. Seasonal corrections are then applied to the  $k$ -value based on the seasonal moisture conditions predicted through the EICM.

### *PCC Overlay of HMA Pavements*

The above discussion focused on PCC overlays of PCC pavements, but the  $k$ -value for the design of PCC overlays over HMA pavements must also be considered. Although the MEPDG documentation does not provide clear information on how the structure is modeled, it appears that based on a limited parametric study, the composite- $k$ -value consists of all layers below the existing HMA pavement. The transformation of the actual pavement structure into an equivalent pavement structure used in the analysis is shown in figure 62. Because a valid method was not available at the time of this report for backcalculating the  $k$ -value of an existing HMA pavement, it is recommended that the elastic modulus of each layer be backcalculated as described above for flexible pavements.

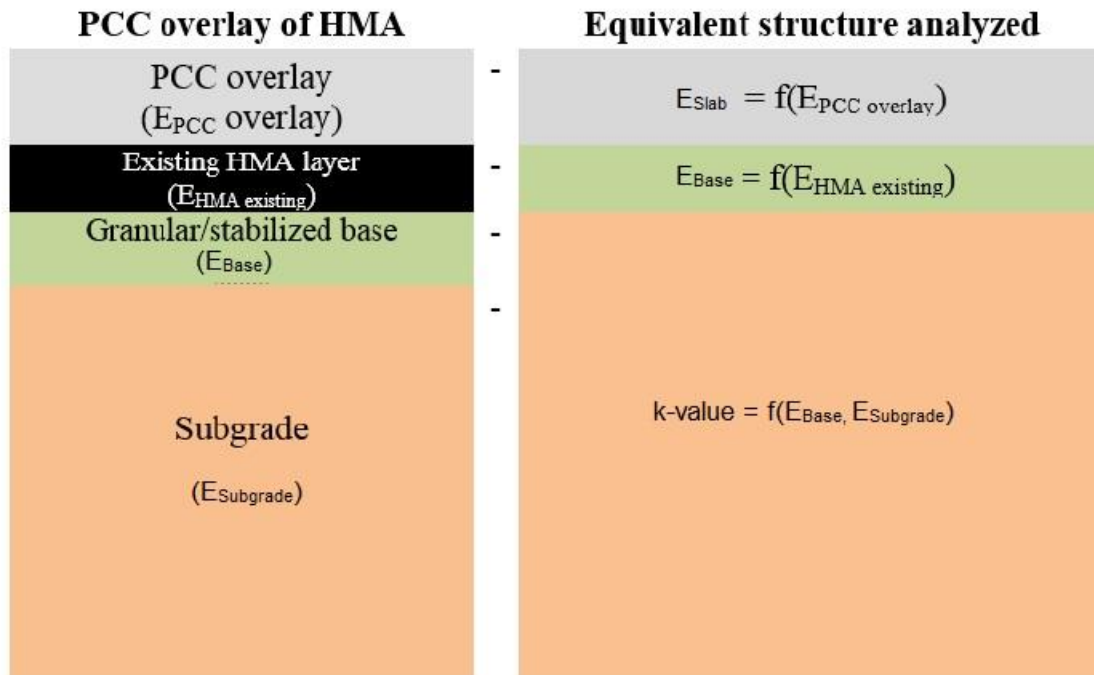

**Figure 62. Diagram. Transforming the actual pavement structure into an equivalent structure for a PCC overlay of an existing HMA pavement.**

## PCC Parameters

The elastic modulus of the existing slab must be determined for overlay designs and existing JPCP being considered for restoration. The elastic modulus can be determined by retrieving cores and measuring the chord modulus based on ASTM C469 or by using FWD data to backcalculate the modulus.<sup>(55)</sup> The MEPDG indicates a backcalculated modulus must be multiplied by 0.8 to convert it from a dynamic value to a static, elastic modulus. In addition, the elastic modulus determined either from backcalculation or laboratory testing must be adjusted to reflect the overall condition of the pavement (for unbonded overlays only). The procedure for using the backcalculated PCC elastic modulus for rehabilitation is summarized as follows:<sup>(1)</sup>

1. Estimate the project mean PCC modulus,  $E_{TEST}$ , by backcalculation using the Best Fit method. Multiply this backcalculated value by 0.8 to arrive at a static elastic modulus for the uncracked PCC.
2. Determine the overall condition of the existing pavement according to the guidelines presented in part 2, chapter 5 of the MEPDG. Choose a pavement condition factor,  $C_{BD}$ , based on the existing pavement condition, as presented in the MEPDG and summarized in table 33 (and also described in table 30, presented earlier).

**Table 33. Condition factor values used to adjust moduli of intact slabs.<sup>(1)</sup>**

Pavement Condition	Condition Factor, $C_{BD}$
Good	0.42 to 0.75
Moderate	0.22 to 0.42
Severe	0.042 to 0.22

3. Calculate  $E_{BASE/DESIGN} = (C_{BD})(E_{TEST})$  to determine the design modulus input of the existing PCC slab.

The PCC flexural strength of the existing slab is also required for overlay design. As previously indicated, for JPCP, the MEPDG recommends prismatic beams be obtained from the existing pavement for level 1, while level 2 is based on relating core compressive strengths; for CRCP, indirect tensile strength is the required input. Although the MEPDG recommends retrieving beams for level 1 and correlating compression strength for level 2 for JPCP, the use of split tensile strength determined from cores and correlated to flexural strength is often the preferred method. For pavement restoration, the PCC elastic modulus is assumed not to increase over time because the strength and stiffness of mature concrete will not significantly change.

## COMPOSITE (HMA/PCC) PAVEMENT INPUTS IN THE MEPDG

The MEPDG evaluates HMA/PCC pavements in two steps. First, the pavement system is analyzed as a rigid pavement to model continued cracking of the underlying PCC pavement. The HMA distresses are then modeled, including thermal cracking, fatigue cracking, and rutting, and overall IRI is also evaluated. Assuming that the analysis is conducted for a new HMA overlay, the key input parameters for this analysis obtained from FWD data are the subgrade  $k$ -value, the  $E_{PCC}$ , and the PCC modulus of rupture (based on backcalculated PCC modulus). The joint LTE is also used in reflection cracking prediction, but only qualitative results (good or poor) are used.

At the time of this report, the MEPDG did not use the backcalculated HMA overlay modulus in the design structure.<sup>(1)</sup>

The backcalculation results for HMA/PCC pavements may contain greater variability than those for other pavement types, largely because the data may reflect test points conducted over joints or cracks in the underlying PCC pavement. For valid results, the locations of the joints in the underlying pavement should be identified, and the testing should be performed at midslab. Any significant deviations from the representative values may be an indication that the testing was conducted too close to underlying cracks or joints, and those results should be excluded in determining the average  $k$  and  $E$  values. For the evaluation of the structural adequacy of the underlying PCC pavement, the elastic modulus determined over the intact portion of the slab is needed. However, those points may be an indication of an area of localized weakness and reveal the need for corrective action.

### **Effective $k$ -Value**

For rehabilitation design of HMA/PCC pavements, MEPDG allows entry of the backcalculated  $k$ -value directly. Both the dynamic  $k$ -value and month of testing are entered. However, the backcalculated  $k$ -value is treated as discussed above for rigid pavement rehabilitation design; the user is still required to enter resilient moduli for all unbound layers and subgrade. The MEPDG processes the input as usual (for new design) and determines the seasonal  $k$ -values based on EICM results using the  $E$ -to- $k$  conversion procedure. If the backcalculated  $k$ -value is entered, the seasonal adjustment is made using the relative  $k$ -values obtained through the  $E$ -to- $k$  conversion process as the scaling factors.

For the HMA analysis, the seasonal resilient moduli are used, but no adjustment is made to account for any difference between the  $k$ -value from the  $E$ -to- $k$  conversion process and the backcalculated  $k$ -value. To ensure consistency between the backcalculated  $k$ -value and the resilient moduli used in the HMA analyses, an iterative procedure may be used to adjust the subgrade resilient modulus input, rather than simply entering the backcalculated  $k$ -value. This involves adjusting the input subgrade resilient modulus up or down to match the  $k$ -value from the  $E$ -to- $k$  conversion process and the backcalculated  $k$ -value for the month of the FWD testing. If the backcalculated  $k$ -value is entered directly, there may be some discrepancy between the  $k$ -value used in the PCC analysis and the resilient moduli used in the HMA analysis; however, this minor discrepancy is not likely to have any significant effect on the predicted HMA overlay performance.

The evaluation of FWD data is perhaps more difficult for HMA/PCC pavements than for other pavement types because of the complications introduced by the compression of the HMA layer. On the other hand, the structural adequacy is not always the principal concern for HMA/PCC pavements. Placing even a relatively thin layer of HMA (75 to 100 mm (3 to 4 inches)) can greatly reduce the critical stresses in the underlying PCC pavement for the following reasons:

- Additional stiffness provided by the HMA overlay. The HMA overlay bonds to the PCC layer to provide a significant increase in the structural capacity.

- Significant reduction in temperature gradients. On PCC pavements, the curling stresses can make up more than 50 percent of the combined stresses during the critical periods when the pavement is subjected to high temperature gradients (positive or negative). The most severe temperature changes occur within the top 75 mm (3 inches) of the pavement. The placement of an HMA overlay significantly reduces the magnitude of the temperature gradients.
- Reduction in contact pressure. The HMA layer reduces the contact pressure on PCC pavement by spreading the load over a larger area.

The combined effect of these factors is that the critical stresses in the PCC pavement drop to a fraction of those occurring before overlaying, even for a 75-mm (3-inch) HMA overlay. Thus, the performance life of HMA/PCC is typically governed by material and functional factors, not structural failure of the underlying PCC pavement. The key distresses include rutting, reflection cracking, and deterioration of the reflected cracks. The structural evaluation of HMA/PCC pavements is primarily a design check to ensure that the stresses are well within the tolerable limits. Therefore, the backcalculation procedure for HMA/PCC does not need to be as comprehensive.

### **PCC Parameters**

The PCC parameters discussed above for rigid pavements also apply to composite pavement structures. However, the difficulty with composite pavements is that the condition of the PCC pavement is not readily visible because of the presence of the existing overlay. Judgment needs to be applied using backcalculated modulus results, existing surface conditions, and historical performance data, to determine an appropriate overall condition of the underlying PCC.

### **OTHER USES OF DEFLECTION DATA IN THE MEPDG**

The following briefly describes the use of other deflection data within the MEPDG.

#### **LTE**

As mentioned previously, LTE is not a direct input in the MEPDG procedure. However, it is used to establish qualitative measures for rehabilitation design. Table 34 summarizes the qualitative ratings based on the determined LTEs from deflection testing.

**Table 34. Summary of qualitative LTE ratings.<sup>(1)</sup>**

<b>Qualitative Description of Load Transfer Rating</b>	<b>LTE (percent)</b>
Excellent	90 to 100
Good	75 to 89
Fair	50 to 74
Poor	25 to 49
Very poor	0 to 24



## **Void Detection**

There is no direct input in the MEPDG to characterize the uniformity of the support conditions beneath the slab. However, it is important to perform FWD testing to detect the presence of voids because the MEPDG design procedure assumes that any voids present will be repaired before the placement of an overlay.

## **MEPDG INPUTS FOR EVALUATION OF EXISTING PAVEMENT LAYERS**

As provided in the *MEPDG Manual of Practice*, table 35 provides a summary of suggested steps for assessing the existing pavement structure.<sup>(2)</sup> Not all suggested steps are required, and the required level of investigation, evaluation, and testing should be based on the knowledge and experience of the design engineer.

**Table 35. Inputs for rehabilitation design using the MEPDG.<sup>(2)</sup>**

<b>Assessment Activity</b>	<b>Input Level 1</b>	<b>Input Level 2</b>	<b>Input Level 3</b>	<b>Purpose of Activity</b>
1. <b>Initial assessment:</b> Review files and historical information, conduct windshield survey	Yes	Yes	Yes	Estimate the overall structural adequacy and materials durability of existing pavement, and segment project into similar condition of the following: <ul style="list-style-type: none"> <li>• Existing layers.</li> <li>• Shoulders, if present.</li> <li>• Drainage features (surface and subsurface).</li> <li>• Identification of potential rehabilitation strategies.</li> </ul>
2. <b>Surface feature surveys:</b> Measure profile, noise, and friction of existing surface	Yes, only profile	Yes, only profile	No	Determine functional adequacy of surface; profile, friction, and noise surveys are only needed to determine whether rehabilitation is needed because the surface usually will be replaced or modified. Profile surveys are used to select a proper rehabilitation strategy—milling depth or diamond grinding, leveling course thickness, or none needed; estimate the initial IRI value after HMA overlay; and determine concrete pavement restoration appropriateness.
3. <b>Detailed condition survey:</b> Determine type, amount, and severity of existing distresses	Yes	Yes	No	Estimate structural adequacy or remaining life and materials durability of existing pavement layers and to select a rehabilitation strategy. <ul style="list-style-type: none"> <li>• Distortion; faulting or PCC and rutting in HMA.</li> <li>• Cracking; nonload-related cracks versus fatigue cracks.</li> <li>• Material disintegration distresses (raveling, D-cracking, etc.).</li> <li>• Definition/segmentation of areas with different distresses.</li> </ul>
4. <b>GPR survey:</b> Estimate layer thickness, locate subsurface anomalies and features	Yes	No	No	Determine structural adequacy, subsurface features and anomalies, and materials durability of existing pavement layers. <ul style="list-style-type: none"> <li>• Estimate layer thickness.</li> <li>• Identify potential subsurface anomalies.</li> <li>• Locate voids beneath pavement surface.</li> <li>• Locate HMA layers with stripping.</li> </ul>

Assessment Activity	Input Level 1	Input Level 2	Input Level 3	Purpose of Activity
5. <b>Deflection basin tests:</b> Measure load response of pavement structure and foundation	Yes	Yes	No	Determine structural adequacy and in-place modulus of existing pavement layers and foundation. <ul style="list-style-type: none"> <li>• Calculate LTE of cracks and joints in PCC pavements.</li> <li>• Calculate layer modulus.</li> <li>• Locate borings and cores for destructive tests.</li> </ul> Level 1—Clustered spacing of deflection basin tests in areas with different distresses along entire project. Level 2—Uniform spacing of deflection basin tests in areas with different distresses.
6. <b>Destructive sampling:</b> Drill cores and boring to recover materials for visual observation and laboratory testing	Yes	Yes	Yes	Determine structural adequacy and materials durability. <ul style="list-style-type: none"> <li>• Perform visual classification of materials and soils.</li> <li>• Confirm layer thickness and material types.</li> <li>• Identify/confirm subsurface anomalies—HMA stripping, voids, etc.</li> <li>• Determine depth to rigid layer or bedrock.</li> <li>• Determine water table depth.</li> <li>• Identify seams with lateral water flow.</li> </ul> Levels 1 and 2—Boring and cores drilled in each segment identified from the condition survey, deflection basin tests, and GPR survey. Level 3—Limited borings in areas identified from the initial pavement assessment activity.
7. <b>Field inspection:</b> Cores and trenches in distressed areas	Yes	No	No	Determine structural adequacy and select rehabilitation strategy: <ul style="list-style-type: none"> <li>• Determine the rutting in each paving layer from the excavated trenches.</li> <li>• Determine where cracking initiated and the direction of crack propagation.</li> </ul>
8. <b>Field tests:</b> DCP tests of unbound layers	Yes	No	No	Determine structural adequacy—estimate the in-place modulus from DCP tests performed on the unbound layer through the core locations.
9. <b>Field inspections:</b> Subsurface drainage features	Yes	No	No	Determine subsurface drainage adequacy—Inspect drainage features with mini-cameras to check condition of and ensure positive drainage of edge drains.

Assessment Activity	Input Level 1	Input Level 2	Input Level 3	Purpose of Activity
<p>10. <b>Laboratory tests:</b>            Unbound materials and soils, HMA mixtures, and PCC mixtures</p>	Yes	Yes	No	<p>Determine layers that will remain in place after rehabilitation:</p> <ul style="list-style-type: none"> <li>• Classification tests (gradation and Atterberg limits).</li> <li>• Unit weight and moisture content tests.</li> <li>• Coefficient of thermal expansion—PCC.</li> <li>• Strength tests—PCC and HMA layers.</li> <li>• Modulus tests—PCC layers only.</li> </ul> <p>Level 1—Laboratory tests listed above.            Level 2—Modulus estimated from DCP and deflection basin tests for unbound layers and volumetric properties for bound layers.            Level 3—All inputs based on defaults and visual classification of materials and soils; no laboratory tests are performed on layers that will remain in place.</p>

**SUMMARY**

This chapter summarizes mechanistic-empirical pavement design principles, provides an overview of the MEPDG, and summarizes inputs (including deflection data) for use in the MEPDG for the design of rehabilitated pavements. Specifically related to the use of deflection data, table 36 summarizes how deflection data can be used within the MEPDG (applicable for level 1 inputs only).

**Table 36. Use of deflection data in the MEPDG.**

Existing Pavement Layer	Measure	Procedure
All pavement types	Pavement condition uniformity	<ul style="list-style-type: none"> <li>Evaluate deflections (e.g., using center deflection or deflection basin parameter) over length of project to determine whether subsection is necessary (subsections may require different overlay thicknesses based on level of deflection/distress).</li> </ul>
HMA	Dynamic modulus, $E_{HMA}$	<ul style="list-style-type: none"> <li>Backcalculate existing (damaged) layer moduli (<math>E_{FWD}</math>) from deflection testing.*</li> <li>Determine undamaged layer moduli (<math>E^*</math>) through laboratory testing of field cores.</li> <li>Calculate damage factor (<math>d_{ac}</math>).</li> <li>Determine the modulus master curve using <math>d_{ac}</math>.*</li> <li>Determine field master curve for existing layer and adjust for rate of loading and surface temperature at the time of NDT testing.</li> </ul>
PCC	Elastic modulus, $E_{BASE/DESIGN}$	<ul style="list-style-type: none"> <li>Backcalculate PCC-layer modulus (<math>E_{TEST}</math>).</li> <li>Multiply <math>E_{TEST}</math> by 0.8 to convert from a dynamic to a static elastic modulus.</li> <li>Determine condition of existing pavement and select a pavement condition factor (<math>C_{BD}</math>).</li> <li>Calculate <math>E_{BASE/DESIGN} = (C_{BD})(E_{TEST})</math>.</li> </ul>
	PCC flexural strength, $E_c$	MEPDG highly recommends laboratory testing of field-obtained beams or correlation with splitting tensile strength from cores for JPCP; and indirect tensile strength for CRCP.
	Effective $k$ -value	<ul style="list-style-type: none"> <li>Use backcalculation procedures that directly produce the effective dynamic <math>k</math>-value.</li> <li>Determine <math>k</math>-value by rehabilitation strategy:               <ul style="list-style-type: none"> <li>HMA overlay—not used in MEPDG.</li> <li>Bonded PCC overlay—backcalculated <math>k</math>-value can be used directly if existing PCC is on a stabilized base. For PCC over unstabilized base, use PCA method to negate the effects of the unstabilized base.<sup>(68)</sup> In addition, select a typical value for the base elastic modulus if unstabilized, and if stabilized, use the method proposed by Ioannides and Khazanovich.<sup>(69)</sup></li> <li>Unbonded PCC overlay—use same procedure as outlined for bonded PCC overlay.</li> <li>PCC overlay of HMA—determine existing layer moduli as described for HMA pavements.</li> </ul> </li> </ul>

\*Revised 5/20/2025

Existing Pavement Layer	Measure	Procedure
	Joint (LTE)	LTE is not an MEPDG input; however, it is used for determining the need for retrofit dowels in JPCP and controlling punchout-related longitudinal cracking.
	Loss of support under corner (void detection)	The presence of voids is not a direct input for the MEPDG; however, the MEPDG assumes that voids are addressed before overlay placement.
Chemically stabilized materials (lean concrete, cement stabilized base, lime/cement/fly ash stabilized soils)	Modulus, $E_{CTB}$	<ul style="list-style-type: none"> <li>• Backcalculate existing (damaged) layer moduli (<math>E_{CTB}</math>) from deflection testing. If layer is less than 150 mm (6 inches) in depth, backcalculation may be problematic and laboratory testing to determine layer moduli may be required.</li> <li>• Determine intact modulus (<math>E_{max}</math>) of intact (undamaged) cores from compressive strength testing.</li> <li>• Determine damage level (<math>d_{CTB}</math>).</li> <li>• Adjust <math>E_{CTB}</math> for layer and surface condition.</li> </ul>
Unbound materials	Resilient modulus, $M_R$	<ul style="list-style-type: none"> <li>• Backcalculate existing layer modulus (<math>E_R</math>) from deflection testing.</li> <li>• Apply modulus ratio (<math>M_R/E_R</math>) to adjust backcalculated to laboratory-obtained values. MEPDG suggests adjustment factors of 0.40 for subgrade soils and 0.67 for granular bases and subbases, (see also table 32).</li> </ul>

## CHAPTER 5. SUMMARY

This report presents guidelines for users who want to perform deflection testing, analysis, and interpretation. Deflection testing is recognized as an effective method for determining the material parameters of in-place pavement layers, the structural condition of existing pavements, LTE of PCC pavement joints and cracks, and the presence of voids beneath PCC pavements. The major factors affecting pavement deflections are discussed, including the pavement structure (type and thickness), pavement loading conditions (load magnitude and type of loading), and climatic forces (temperature and moisture effects).

FWD testing guidelines are provided and include recommendations for sensor configuration, number of drops and load levels, testing location, testing increments, deflection testing data checks, and safety procedures for use during FWD testing. Backcalculation guidelines include an overview of the backcalculation process, data inputs and suggested default values, measures of convergence, and a summary of various studies that have verified backcalculation results and evaluated backcalculated versus laboratory determined moduli. Finally, a summary of mechanistic-empirical pavement design principles, an overview of the MEPDG, a summary of inputs (including deflection data) for use in the MEPDG for rehabilitation design, and a summary of how deflection basins can be used in rehabilitation strategy selection and design are provided.





## GLOSSARY OF TERMS

**Aggregate:** A collective term for the mineral materials such as sand, gravel, and crushed stone that are used with a binding medium (such as water, bitumen, portland cement, lime, etc.) to form compound materials (i.e., asphalt concrete, portland cement concrete, etc.).<sup>(70)</sup>

**Alligator cracking:** Interconnected or interlaced cracks forming a pattern that resembles an alligators hide.<sup>(71)</sup>

**Analysis period:** The period of time used in making economic comparisons between rehabilitation alternatives. The analysis period should not be confused with the pavement's design life (performance period).<sup>(71)</sup>

**Asphalt concrete (AC):** A controlled mixture of asphalt cement and graded aggregate compacted to a dense mass. Also referred to as hot-mix asphalt (HMA).<sup>(72)</sup>

**Axle load:** Load exerted by a vehicle on the pavement surface via an axle.

**Base:** The layer or layers of specified or select material of designated thickness placed on a subbase or subgrade to support a surface course; layer directly beneath a PCC slab.<sup>(71)</sup>

**Backcalculation:** An iterative process by which pavement layer moduli, or other stiffness properties, are estimated from FWD deflection data. The process begins with a hypothesis of a given layer's modulus, which is repeatedly compared with the FWD's output using an iterative mathematical model. The iteration stops once a predetermined level of tolerance has been reached between subsequent calculated estimates.<sup>(4)</sup>

**Chemically stabilized mixtures:** Subgrade materials whose plasticity characteristics have been modified using materials such as lime, fly ash, or PCC.

**Composite pavement:** A pavement structure composed of an asphalt concrete wearing surface and PCC slab, or an asphalt concrete overlay of a PCC slab.<sup>(71)</sup>

**Continuously reinforced concrete pavement (CRCP):** PCC pavement containing longitudinal reinforcement at or above mid-depth designed to hold shrinkage cracks tightly closed. Transverse joints exist only for construction purposes and on-grade structures. Transverse reinforcement may or may not exist. Longitudinal joints exist similar to other types of concrete pavements.<sup>(72)</sup>

**Crack:** A break or disruption in the continuity of the pavement surface that may extend through the entire pavement thickness.

**Crushed stone:** A base (or subbase) course of designed thickness and constructed of graded and mechanically crushed mineral aggregate compacted above the subgrade.<sup>(72)</sup>

**Curling:** Deformation of a PCC slab caused by a temperature difference between the upper and lower surfaces.<sup>(73)</sup>

**Deflection:** Vertical deformation of a pavement under an applied load.<sup>(73)</sup>

**Deflection basin:** The bowl shape of the deformed pavement surface caused by a specialized load as depicted from the peak measurements of a series of deflection sensors placed at radial offsets from the center of the load plate.<sup>(18)</sup>

**Deflection sensor:** An electronic device(s) capable of measuring the relative vertical movement of a pavement surface and mounted to reduce angular rotation with respect to its measuring axis at the expected movement. Such devices may include seismometers, velocity transducers (geophones), or accelerometers.<sup>(18)</sup>

**Deviator stress:** In triaxial testing the difference between the axial stress applied by the testing apparatus and the confining stress (pressure).

**Dowel:** A load transfer device across a joint (usually a transverse joint) in a rigid slab, usually consisting of a plain cylindrical steel bar.<sup>(71)</sup>

**Drop sequence:** A sequence of load levels used during FWD testing.

**Dynamic cone penetrometer (DCP):** Testing apparatus for measuring the resistance of a granular material or soil against penetration of a cone driven into the soil by repetitive droppings of a mass on an anvil.

**Elastic modulus:** The relationship between stress and strain within a material's elastic range. Thus, the flexibility of any object depends on its elastic modulus and geometric shape; however, it is important to note that strength (stress needed to break something) is not the same thing as stiffness (as measured by elastic modulus).<sup>(70)</sup>

**Equivalent single axle load (ESAL):** A numerical factor that expresses the relationship of a given axle load to another axle load in terms of the relative effects of the two loads on the serviceability of a pavement structure. ESALs are often expressed in terms of 80 kN (18,000-lb) single-axle loads.<sup>(71)</sup>

**Falling weight deflectometer (FWD):** Trailer- or truck-mounted equipment that applies an impact load to a pavement structure by means of a mass dropping on a set of buffers mounted on a loading plate resting on the pavement surface and measures the resulting deflections of the pavement.

**Forward calculation:** A noniterative process in which stresses, strains, and displacements are calculated from layer data and applied load.<sup>(4)</sup>

**Fatigue cracking:** Cracking of the pavement surface as a result of repetitive loading; may be manifested as longitudinal or alligator cracking in the wheelpaths for flexible pavement and transverse cracking (and sometime longitudinal cracking) for jointed concrete pavement.

**Faulting:** Difference in elevation across a joint or crack.

**Flexible pavement:** A pavement structure that maintains intimate contact with and distributes loads to the subgrade and depends on aggregate interlock, particle friction, and cohesion for stability.<sup>(71)</sup>

**Gravel:** Coarse aggregate resulting from natural disintegration and abrasion of rock or processing of weakly bound conglomerate.<sup>(72)</sup>

**Ground-penetrating radar (GPR):** Noninvasive tool that has been used to map subsurface conditions in a wide variety of applications. GPR is basically a subsurface anomaly detector; as such it will map changes in the underground profile due to contrasts in the electromagnetic conductivity across material interfaces. In a GPR system, short pulses of radio wave energy travel through the pavement structure and create echoes at boundaries of dissimilar materials, such as at an asphalt-base interface.<sup>(70)</sup>

**Hot-mix asphalt (HMA):** A controlled mixture of asphalt cement and graded aggregate compacted to a dense mass. Also referred to as asphalt concrete (AC).<sup>(72)</sup>

**International Roughness Index (IRI):** A measure of a pavement's longitudinal surface profile as measured in the wheelpath by a vehicle traveling at typical operating speeds. It is calculated as the ratio of the accumulated suspension motion to the distance traveled obtained from a mathematical model of a standard quarter car traversing a measured profile at a speed of 80 km/h (50 mi/h). The IRI is expressed in units of meters per kilometer (inches per mile) and is a representation of pavement roughness.<sup>(1)</sup>

**Joint:** A pavement discontinuity, either longitudinal or transverse, made necessary by design or by interruption of a paving operation.

**Jointed plain concrete pavement (JPCP):** Jointed PCC pavement containing transverse joints spaced to accommodate temperature gradient and drying shrinkage stresses to avoid cracking. This pavement contains no distributed steel to control random cracking and may or may not contain joint load transfer devices.<sup>(72)</sup>

**Lean concrete base:** A base course constructed of mineral aggregates plant mixed with a sufficient quantity of portland cement to provide a strong platform for additional pavement layers and placed with a paver.<sup>(72)</sup>

**Leveling course:** A first lift applied to an existing pavement used to fill in ruts and make up elevation differences.<sup>(70)</sup>

**Lime stabilized:** A prepared and mechanically compacted mixture of hydrated lime, water, and soil supporting the pavement system that has been engineered to provide structural support.<sup>(72)</sup>

**Linear elastic:** A material property that allows an object or material to return to or be capable of returning to an initial form or state after deformation in a linear manner (e.g., a plot of a linear elastic material would show a straight line). Almost no material is completely linearly elastic, but many materials are linearly elastic over a certain range of stress/strain.<sup>(70)</sup>

**Load cell:** A cell capable of accurately measuring the load that is applied to the load plate and placed in a position to minimize the mass between itself and the pavement. The load cell should be positioned in such a way that it does not restrict the ability to obtain deflection measurements under the center of the load plate. The load cell should be water resistant and resistant to mechanical shocks from road impacts during testing or traveling.<sup>(18)</sup>

**Load transfer efficiency (LTE):** The ability of a joint or crack to transfer load from one side to another.

**Loading plate:** A plate capable of an even distribution of the load over the pavement surface for measurements on conventional roads and airfields or similar stiff pavements. The plate should be suitably constructed to allow pavement surface deflection measurements at the center of the plate.<sup>(18)</sup>

**Longitudinal cracking:** Pavement cracking predominately parallel to the direction of traffic.

**Maintenance:** The preservation of the entire roadway, including surface, shoulders, roadsides, structures, and traffic control devices.<sup>(71)</sup>

**Mechanistic-empirical:** A design philosophy or approach in which fundamental material responses are used in conjunction with empirically derived relationships to accomplish the design objectives.

**Milling:** Mechanical process in which a portion of a pavement surface is removed.

**Modulus of elasticity ( $E$ ):** The stiffness of a material as defined in terms of the ratio of stress to strain in the elastic portion of a stress-strain curve.

**Modulus of rupture ( $MR$ ):** The flexural bending strength of concrete.

**Modulus of subgrade reaction ( $k$ ):** Westergaard's modulus of subgrade reaction for use in rigid pavement design (the load in pounds per square inch on a loaded area of the roadbed soil or subbase divided by the deflection in inches of the roadbed soil or subbase, MPa/mm (lbf/inches<sup>2</sup>/inch)). The value used in design is the dynamic modulus of subgrade reaction as directly backcalculated from FWD deflections or backcalculated from deflections obtained from the elastic layered program where resilient moduli values are assigned to each layer. The traditional modulus of subgrade reaction is the static value which is approximately one-half that of the dynamic value.<sup>(71)</sup>

**Nonlinear material:** A pavement material having properties such that the relationship between stress and strain is nonlinear.

**Pavement performance:** Measure of accumulated service provided by a pavement (i.e., the adequacy with which it fulfills its purpose). Often referred to as the record of pavement condition or serviceability over time or with accumulated traffic.<sup>(71)</sup>

**Pavement structure:** A combination of subbase, base course, and surface course placed on a subgrade to support the traffic load and distribute it to the roadbed.<sup>(71)</sup>

**Portland cement concrete (PCC):** A composite material consisting of portland or hydraulic cement, water, and coarse and fine aggregate.

**Poisson's ratio:** Ratio of the transverse strain (perpendicular to the applied load) and longitudinal strain (elongation) of a material specimen in one-direction loading conditions.

**Raveling:** A pavement distress characterized by the loss of surface material and degradation of the binder material.

**Reflective cracking:** Cracks in asphalt or concrete surfaces of pavements occurring over joints or cracks in underlying layers.

**Resilient modulus ( $M_R$ ):** A standardized measurement of the modulus of elasticity of roadbed soil or other pavement material.<sup>(71)</sup>

**Rigid pavement:** A pavement structure that distributes loads to the subgrade, having as one course a PCC slab of relatively high-bending resistance.<sup>(71)</sup>

**Roadbed:** The graded portion of a highway between top and side slopes, prepared as a foundation for the pavement structure and shoulder.<sup>(71)</sup>

**Rutting:** Longitudinal surface depressions in the wheelpath of an HMA pavement caused by plastic movement of the HMA mix, inadequate compaction, or abrasion from studded tires (such abrasion can also be observed on PCC pavements).<sup>(74)</sup>

**Soil aggregate:** Natural or prepared mixtures consisting predominantly of stone, gravel, or sand that contain a significant amount of  $-75\text{-}\mu\text{m}$  (No. 200) silt-clay material.<sup>(72)</sup>

**Soil cement:** A mechanically compacted mixture of soil, portland cement, and water, used as a layer in a pavement system to reinforce and protect the subgrade or subbase.<sup>(75)</sup>

**Spalling:** The cracking, breaking, or chipping of pavement edges in the vicinity of a joint or crack.<sup>(74)</sup>

**Stabilized base:** A base course constructed with a stabilizing material, usually AC or portland cement.<sup>(72)</sup>

**Subbase:** The layer or layers of specified or selected materials of designated thickness placed on a subgrade to support a base course.<sup>(71)</sup>

**Subgrade:** The top surface of a roadbed upon which the pavement structure and shoulders are constructed.<sup>(71)</sup>

**Surface Curvature Index (SCI):** Difference between the deflection recorded at the center of the dynamic load and the deflection recorded at a nearby offset (usually up to 900 mm (35 inches) maximum).<sup>(70)</sup>

**Transverse cracking:** A discontinuity in a pavement surface that runs generally perpendicular to the pavement centerline. In HMA pavements, transverse cracks often form as a result of thermal movements of the pavement or reflection from underlying layers. In PCC pavements, transverse cracks may be caused by fatigue, loss of support, or thermal movements.<sup>(74)</sup>

**Warping:** Deformation of a PCC slab caused by a moisture differential between the upper and lower surfaces.<sup>(74)</sup>

**Wheel load:** The portion of a loaded axle that is transmitted to the pavement on a wheel.

## REFERENCES

1. American Association of State Highway and Transportation Officials. (2004) *Guide for Mechanistic-Empirical Design of New and Rehabilitated Pavement Structures, Parts 1–4*. NCHRP 1-37A Research Report. National Cooperative Highway Research Program, Transportation Research Board, and American Association of State Highway and Transportation Officials, Washington, DC.
2. American Association of State Highway and Transportation Officials. (2008) *Mechanistic-Empirical Pavement Design Guide—A Manual of Practice (Interim Edition)*. American Association of State Highway and Transportation Officials, Washington, DC.
3. Pavement Interactive. (2010) *Deflection*. Available at <http://www.pavementinteractive.org/article/deflection/>. Last accessed July 1, 2016.
4. Alavi, S., LeCates, J.F., and Tavares, M.P. (2008) *Falling Weight Deflectometer Usage*. NCHRP Synthesis of Highway Practice 381. National Cooperative Highway Research Program, Transportation Research Board, Washington, DC.
5. Hveem, F.N. (1955) “Pavement Deflections and Fatigue Failures.” *Highway Research Board Bulletin 114*. Highway Research Board, Washington, DC.
6. Stubstad, R.N. (2002) *LTPP Data Analysis: Feasibility of Using FWD Deflection Data to Characterize Pavement Construction Quality*. NCHRP Web Document 52. National Cooperative Highway Research Program, Transportation Research Board, Washington, DC.
7. Hoffman, M.S. and Thompson, M.R. (1981) *Mechanistic Interpretation of Nondestructive Pavement Testing Deflections*. Report No. FHWA/IL/UI-190. Illinois Department of Transportation, Springfield, IL.
8. Washington State Department of Transportation. (2001) *FWD-AREA Program*. Washington State Department of Transportation, Olympia, WA.
9. Lukanen, E.O., Stubstad, R., and Briggs, R. (2000) *Temperature Predictions and Adjustment Factors for Asphalt Pavement*. Report No. FHWA-RD-98-085. Federal Highway Administration, Washington, DC.
10. Horak, E. and Emery, S. (2009) “Evaluation of Airport Pavements with FWD Deflection Bowl Parameter Benchmarking Methodology.” *Proceedings, 2nd European Airport Pavement Workshop, 13–14 May 2009*. Amsterdam, The Netherlands.
11. COST-Transport. (2005) *Use of Falling Weight Deflectometers in Pavement Evaluation*. COST Action 336. European Cooperation in the Field of Scientific and Technical Research, European Commission Directorate General Transport, The Netherlands.

12. Hoerner, T.E., Smith, K.D., Yu, H.T., Peshkin, D.G., and Wade, M.J. (2001) *PCC Pavement Evaluation and Rehabilitation*. Reference Manual. NHI Course 131062. National Highway Institute, Arlington, VA.
13. Darter, M.I., Barenberg, E.J., and Yrjanson, W.A. (1985) *Joint Repair Methods for Portland Cement Concrete Pavements*. NCHRP Report 281. National Cooperative Highway Research Program, Transportation Research Board, Washington, DC.
14. Schmalzer, P.N. (2006) *LTPP Manual for Falling Weight Deflectometer Measurements*. Version 4.1. Report No. FHWA-HRT-06-132. Federal Highway Administration, Washington, DC.
15. Dynatest® Consulting, Inc. (2009) *Dynatest® Falling Weight Deflectometers*. Available at <http://www.dynatest.com/structural-hwd-fwd.php>. Last accessed May 3, 2010.
16. ASTM D4694-09. (2015) “Standard Test Method for Deflections with a Falling-Weight-Type Impulse Load Device.” *Book of Standards Volume 04.03*, ASTM International, West Conshohocken, PA.
17. Association of State Highway Transportation Officials. (2006) *Standard Method of Test for Pavement Deflection Measurements*. Association of State Highway and Transportation Officials, Washington, DC.
18. ASTM D4695-03. (2015) “Standard Guide for General Pavement Deflection Measurements.” *Book of Standards Volume 04.03*, ASTM International, West Conshohocken, PA.
19. Alam, J., Galal, K.A., and Diefenderfer, B.K. (2007) *Statistical Determination of Minimum Testing Intervals and Number of Drop Levels for Network Level Falling Weight Deflectometer Testing on Virginia’s Interstate System*. Report No. 07-1876. Transportation Research Board, Washington, DC.
20. Zhang, Z., Damnjanovic, L.M.I., and Li, Z. (2003) *Development of a New Methodology for Characterizing Pavement Structural Condition for Network-Level Applications*. Report No. FHWA/TX-04/0-4322. Texas Department of Transportation, Austin, TX.
21. U.S. Army Corps of Engineers. (2001) *UFC-3-260-03: Airfield Pavement Evaluation*. U.S. Army Corps of Engineers, Washington, DC.
22. Federal Aviation Administration. (2004) *Use of Nondestructive Testing in the Evaluation of Airport Pavements*. Advisory Circular AC 150/5370-11A. U.S. Department of Transportation, Washington, DC.
23. AASHTO R32-09. (2010) “Calibrating the Load Cell and Deflection Sensors for a Falling Weight Deflectometer.” *Standard Specifications for Transportation Materials and Methods of Sampling and Testing, Part 1B: Specifications*. Association of State Highway and Transportation Officials, Washington, DC.



24. Stubstad, R.N., Jiang, Y.J., Clevenson, M.L., and Lukanen, E.O. (2006) *Review of the Long-Term Pavement Performance Backcalculation Results—Final Report*. Report No. FHWA-HRT-05-150. Federal Highway Administration, Washington, DC.
25. Mahoney, J.P., Jackson, N.C., and Pierce, L.M. (1992) *Pavement NDT Data Applications, Course Notes*. Washington State Transportation Center, Seattle, WA.
26. Bu-Bushait, A.A. (1985) *Development of a Flexible Pavement Fatigue Model for Washington State*. Ph.D. Dissertation. Department of Civil and Environmental Engineering, University of Washington, Seattle, WA.
27. Mahoney, J.P., Jackson, N.C., and Pierce, L.M. (1995) *WSDOT Pavement Guide*. Washington State Department of Transportation, Olympia, WA.
28. Stubstad, R.N., Jiang, Y.J., and Lukanen, E.O. (2006) *Guidelines for Review and Evaluation of Backcalculation Results*. Report No. FHWA-RD-05-152. Federal Highway Administration, Washington, DC.
29. Strategic Highway Research Program. (1993) *SHRP's Layer Moduli Backcalculation Procedure*. Publication No. SHRP-P-655. National Research Council, Washington, DC.
30. Darter, M.I., Elliott, R.P., and Hall, K.T. (1991) "Revision of AASHTO Pavement Overlay Design Procedure." *Transportation Research Record 1374*, p. 36–47. Transportation Research Board, Washington, DC.
31. Washington State Department of Transportation. (2005) *EVERSERIES© User's Guide: Pavement Analysis Computer Software and Case Studies*. Washington State Department of Transportation, Olympia, WA.
32. Rohde, G.T. and Scullion, T. (1990) *MODULUS 4.0: Expansion and Validation of the Modulus Backcalculation System*. Research Report 1123-3. Texas Department of Transportation, Austin, TX.
33. Roesset, J.M., Stokoe II, K.H., and Seng, C.R. (1995) "Determination of Depth to Bedrock from Falling Weight Deflectometer Test Data." *Transportation Research Record 1504*, p. 68–78. Transportation Research Board, Washington, DC.
34. Chatti, K., Ji, Y., Harichandran, R.S., and Hyung, S.L. (2004) *Development of a Computer Program for Dynamic Backcalculation of Flexible Pavement Layer Moduli*. Final Report. Michigan Department of Transportation, Lansing, MI.
35. Khazanovich, L., Tayabji, S.D., and Darter, M.I. (2001) *Backcalculation of Layer Parameters for LTPP Test Sections, Volume I: Slab on Elastic Solid and Slab on Dense-Liquid Foundation Analysis of Rigid Pavements*. Report No. FHWA-RD-00-086. Federal Highway Administration, Washington, DC.

36. Khazanovich, L. (2000) "Dynamic Analysis of FWD Test Results for Rigid Pavements." *Nondestructive Testing of Pavements and Backcalculation of Moduli: Third Volume*. STP 1375. ASTM International, West Conshohocken, PA.
37. Chatti, K. and Kim, T.K. (2001) "Simple Dynamic Backcalculation Procedure for Falling Weight Deflectometer Testing of Rigid Pavements." *Transportation Research Record 1764*, p. 30–38. Transportation Research Board, Washington, DC.
38. Chatti, K., Ji, Y., and Harichandran, R.S. (2006) "Dynamic Backcalculation of Pavement Layer Parameters Using Frequency and Time Domain Methods." *Proceedings, 10th International Conference on Asphalt Pavements*. Quebec City, Quebec, Canada.
39. Ullidtz, P. (2000) "Will Non-linear Backcalculation Help?" *Nondestructive Testing of Pavements and Backcalculation of Moduli: Third Volume*. ASTM STP 1375. ASTM International, West Conshohocken, PA.
40. Richter, C.A. (2006) *Seasonal Variation in the Moduli of Unbound Pavement Layers*. Report No. FHWA-HRT-04-079. Federal Highway Administration, Washington, DC.
41. Ovik, J.M., Birgisson, B., and Newcomb, D.E. (2000) *Characterizing Seasonal Variations in Pavement Material Properties for Use in a Mechanistic-Empirical Design Procedure*. MN/RC-2000-35. Minnesota Department of Transportation, St. Paul, MN.
42. Vandenbossche, J.M. (2002) *Interpreting Falling Weight Deflectometer Results for Curled and Warped Portland Cement Concrete Pavements*. Ph.D. Dissertation. University of Minnesota, Minneapolis, MN.
43. Foxworthy, P.T. (1985) *Concepts for the Development of a Nondestructive Testing and Evaluation System for Rigid Airfield Pavements*. Ph.D. Dissertation. University of Illinois at Urbana-Champaign, Urbana, IL.
44. Crovetto, J.A. (2002) "Deflection-Based Analysis Techniques for Jointed Concrete Pavement Systems." *Transportation Research Record 1809*, p. 3–11. Transportation Research Board, Washington, DC.
45. American Association of State Highway and Transportation Officials. (1998) *Supplement to the AASHTO Guide for Design of Pavement Structures*. American Association of State Highway and Transportation Officials, Washington, DC.
46. Von Quintus, H.L. and Killingsworth, B. (1997) *Backcalculation of Layer Moduli of LTPP General Pavement Study (GPS) Sites*. Report No. FHWA-RD-97-086. Federal Highway Administration, Washington, DC.
47. Von Quintus, H.L. and Killingsworth, B. (1998) *Analysis Relating to Pavement Material Characterizations and their Effects on Pavement Performance*. Report No. FHWA-RD-97-085. Federal Highway Administration, Washington, DC.

48. Clark, T., Irwin, L., and Borter, R. (2007) *MODTAG© User's Manual*, 4th Edition, Virginia Department of Transportation Materials Division and Cornell University, Cornell Local Roads Program, Richmond, VA.
49. Irwin, L.H. (2002) "Backcalculation: An Overview and Perspective." *Proceedings, FWD/Backanalysis Workshop, 6th International Conference on the Bearing Capacity of Roads, Railways and Airfields*. Lisbon, Portugal.
50. Winters, B.C. (1993) *The PACCAR Pavement Test Section—Instrumentation and Validation*. Master's Thesis. Department of Civil Engineering, University of Washington, Seattle, WA.
51. Lenngren, C.A. (1990) *Relating Bearing Capacity to Pavement Condition*. Ph.D. Dissertation. Department of Highway Engineering, Royal Institute of Technology, Stockholm, Sweden.
52. Van Deusen, D. (1996) *Selection of Flexible Backcalculation Software for the Minnesota Road Research Project*. MN/PR-96/29. Minnesota Department of Transportation, Maplewood, MN.
53. Timm, D.H. and Priest, A.L. (2006) *Material Properties of the 2003 NCAT Test Track Structural Study*. NCAT Report 06-01. National Center for Asphalt Technology, Auburn University, Auburn, AL.
54. Appea, A., Flintsch, G.W., and Al-Qadi, I. (2001) "Backcalculation Validation through Field Instrumentation Response at the Virginia Smart Road." *Second International Symposium on Maintenance and Rehabilitation of Pavements and Technological Control*. National Center for Asphalt Technology, Auburn University, Auburn, AL.
55. ASTM C469/C469M-10. (2010) "Standard Test Method for Static Modulus of Elasticity and Poisson's Ratio of Concrete in Compression." ASTM International, West Conshohocken, PA.
56. Zhou, H. (2000) "Comparison of Backcalculated and Laboratory Measured Moduli on AC and Granular Base Layer Materials." *Nondestructive Testing of Pavements and Backcalculation of Moduli: Third Volume*. ASTM STP 1375. ASTM International, West Conshohocken, PA.
57. Kim, D., Ji, Y., and Siddiki, N.Z. (2010) *Evaluation of the In-Situ Stiffness of Subgrade by Resilient and FWD Modulus*. Report No. FHWA/IN/JTRP-2010/17. Indiana Department of Transportation, Indianapolis, IN.
58. Dawson, T.A., Baladi, G.Y., Sessions, C.P., and Haider, S.W. (2009) "Backcalculated and Laboratory-Measured Resilient Modulus Values." *Transportation Research Record 2094*, p. 71–79. Transportation Research Board, Washington, DC.
59. Lu, Q., Jones, D., and Harvey, J.T. (2008) *Reflective Cracking Study: Backcalculation of HVS Test Section Deflection Measurements*. Research Report UCPRC-RR-2007-08. Institute of Transportation Studies, University of California, Davis, Davis, CA.

60. AASHTO M145-91-UL. (2004) "Standard Specification for Classification of Soils and Soil-Aggregate Mixtures for Highway Construction Purposes." Association of State Highway and Transportation Officials, Washington, DC.
61. Van Deusen, D.A., Lenngren, C.A., and Newcomb, D.E. (1994) "A Comparison of Laboratory and Field Subgrade Moduli at the Minnesota Road Research Project." *Nondestructive Testing of Pavements and Backcalculation of Moduli: Third Volume*. ASTM STP 1375. ASTM International, West Conshohocken, PA.
62. Houston, W.N., Mamlouk, M.S., and Perera, R.W.S. (1992) "Laboratory Versus Nondestructive Testing for Pavement Design." *Journal of Transportation Engineering* 118(2), p. 207–222. American Society of Civil Engineers, Reston, VA.
63. Lee, S.W., Mahoney, J.P., and Jackson, N.C. (1988) "Verification of Backcalculation of Pavement Moduli." *Transportation Research Record* 1196, p. 85–95. Transportation Research Board, Washington, DC.
64. Miller, J.S. and Bellinger, W.Y. (2003) *Distress Identification Manual for the Long-Term Pavement Performance Program (Fourth Revised Edition)*. Report No. FHWA-RD-03-031. Federal Highway Administration, Washington, DC.
65. Federal Highway Administration. (2001) *Traffic Monitoring Guide*. U.S. Department of Transportation, Washington, DC.
66. ASTM D5858-96. (2008) "Standard Guide for Calculating In Situ Equivalent Elastic Moduli of Pavement Materials Using Layered Elastic Theory." ASTM International, West Conshohocken, PA.
67. Maser, K.R. (1996) "Evaluation of Pavements and Bridge Decks at Highway Speed Using Ground Penetrating Radar." *Proceedings, ASCE Structures Congress XIV*. Chicago, IL.
68. Portland Cement Association. (1984) *Thickness Design for Concrete Highway and Street Pavements*. Engineering Bulletin EB109.01P. Portland Cement Association, Skokie, IL.
69. Ioannides, A.M. and Khazanovich, L. (1994) "Backcalculation Procedures for Three-Layered Concrete Pavements." *Proceedings, 4th International Conference, Bearing Capacity of Roads and Airfields*. St. Paul, MN.
70. Pavement Interactive. (2016) *Pavement Interactive*. Available at <http://www.pavementinteractive.org>. Last accessed June 2016.
71. Association of State Highway and Transportation Officials. (1993) *Guide for Design of Pavement Structures*. Association of State Highway and Transportation Officials, Washington, DC.
72. Darter, M.I., Von Quintus, H., Jiang, Y.J., Owusu-Antwi, E.B., and Killingsworth, B.M. (1997) *Catalog of Recommended Pavement Design Features*. Final Report. NCHRP Project

- 1-32. National Cooperative Highway Research Program, Transportation Research Board, Washington, DC.
73. McGee, K.H. (1994) *Portland Cement Concrete Resurfacing*. NCHRP Synthesis 204. National Cooperative Highway Research Program, Transportation Research Board, Washington, DC.
74. Miller, J.S. and Bellinger, W.Y. (2014) *Distress Identification Manual for the Long-Term Pavement Performance Program*. Report No. FHWA-HRT-13-092. Federal Highway Administration, Washington, DC.
75. National Highway Institute. (2006) *Geotechnical Aspects of Pavements*. Federal Highway Administration, Washington, DC.



