

August 30, 2023

# **Wetland and Stream Report**

**MT FLAP BOR 2980(1)**

**Sun River Bridge Replacement**

**Lewis and Clark and Teton Counties,  
Montana**

Prepared for  
Federal Highway Administration  
Western Federal Lands Highway Division  
610 East Fifth Street  
Vancouver, WA 98661-3801

through  
Robert Peccia and Associates  
3147 Saddle Drive  
Helena, Montana 59601

Prepared by  
Herrera Environmental Consultants, Inc.  
101 East Broadway, Suite 610  
Missoula, Montana 59802  
Telephone: 406-721-4204





# Contents

Introduction.....	3
Location and Setting.....	3
Project Description.....	5
Methods.....	8
Background Information Review.....	8
OHWM Delineation.....	9
Wetland Investigation.....	9
Results.....	9
Background Review.....	9
Field Survey.....	13
Potential Impacts.....	14
Impact Avoidance and Minimization.....	16
References.....	17

# Appendices

- Appendix A     OHWM Delineation Data Sheet and Photographs
- Appendix B     Bridge Plans

# Figures

Figure 1. Vicinity Map for the Sun River Bridge Replacement Project.....	4
Figure 2. Previously Mapped Streams and Wetlands in the Survey Area.....	11
Figure 3. NRCS Mapped Soils in the Survey Area.....	12
Figure 4. Delineated Features and Proposed Alignment and Clearing Limits.....	15





# Introduction

The Federal Highway Administration (FHWA) is intending to complete the design and National Environmental Policy Act (NEPA) documentation for the Sun River Bridge Replacement project. The Partner Agencies consist of FHWA, Bureau of Reclamation (BOR), Bureau of Land Management (BLM), Greenfields Irrigation District (GID), and US Forest Service (USFS). Herrera Environmental Consultants, Inc. (Herrera) prepared this Wetland and Stream Report to:

- Identify the OHWM of the Sun River upstream and downstream approximately 100 feet at existing and proposed bridge crossings referred to in this report as the *survey area*,
- Field verify presence or non-presence of wetlands within the survey area;
- Identify other Waters of the U.S. within the proposed clearing limits; and
- Identify measures to avoid and minimize impacts to the Sun River.

## Location and Setting

The proposed project is located 73 miles west of Great Falls, Montana, 19 miles northwest of Augusta, Montana, and 0.75 miles downstream from Sun River Diversion Dam (Diversion Dam) near Gibson Reservoir. Sun River Bridge crosses the Sun River and spans the county lines of Lewis and Clark County and Teton County, Montana (Figure 1). The approximate latitude and longitude coordinates for the project are N 47°37'06" and W 112°41'32" in Section 36 of Township 22 North and Range 9 West.

The Sun River has its headwaters in the Bob Marshall Wilderness Area. The river originates at the confluence of the North and South Forks of the Sun River at Gibson Reservoir in the Helena-Lewis and Clark National Forest. Downstream of Gibson Dam the river flows three miles through a mountainous canyon to the Diversion Dam. Below the Diversion Dam the river is entrenched in a narrow valley for about 12 miles, then the valley broadens as the river flows out onto the prairie. Sun River joins the Missouri River at Great Falls, 97 miles downstream of the Diversion Dam (MFWP 2019).

The Sun River supplies irrigation water for the GID. Water stored in Gibson Reservoir is released into the river for diversion downstream at Diversion Dam into the Pishkun Supply Canal (Pishkun Canal). Pishkun Canal conveys water to Pishkun Reservoir or to the Willow Creek Reservoir (GID 2023). A concrete siphon buried parallel to the existing bridge conveys the Pishkun Supply Canal under and across the Sun River.

The Willow Creek Feeder Canal is diverted off the Pishkun Canal just upstream from the siphon. The canal feeds the Willow Creek Reservoir, approximately 11 miles southeast of the diversion point. Water from the reservoir flows back into the Sun River (BOR 2023).

The Sun River in the survey area is in a steep canyon with a narrow strip of riparian vegetation along the river's edge. The left bank of the river located upstream of the existing bridge is rocky and only moderately vegetated.

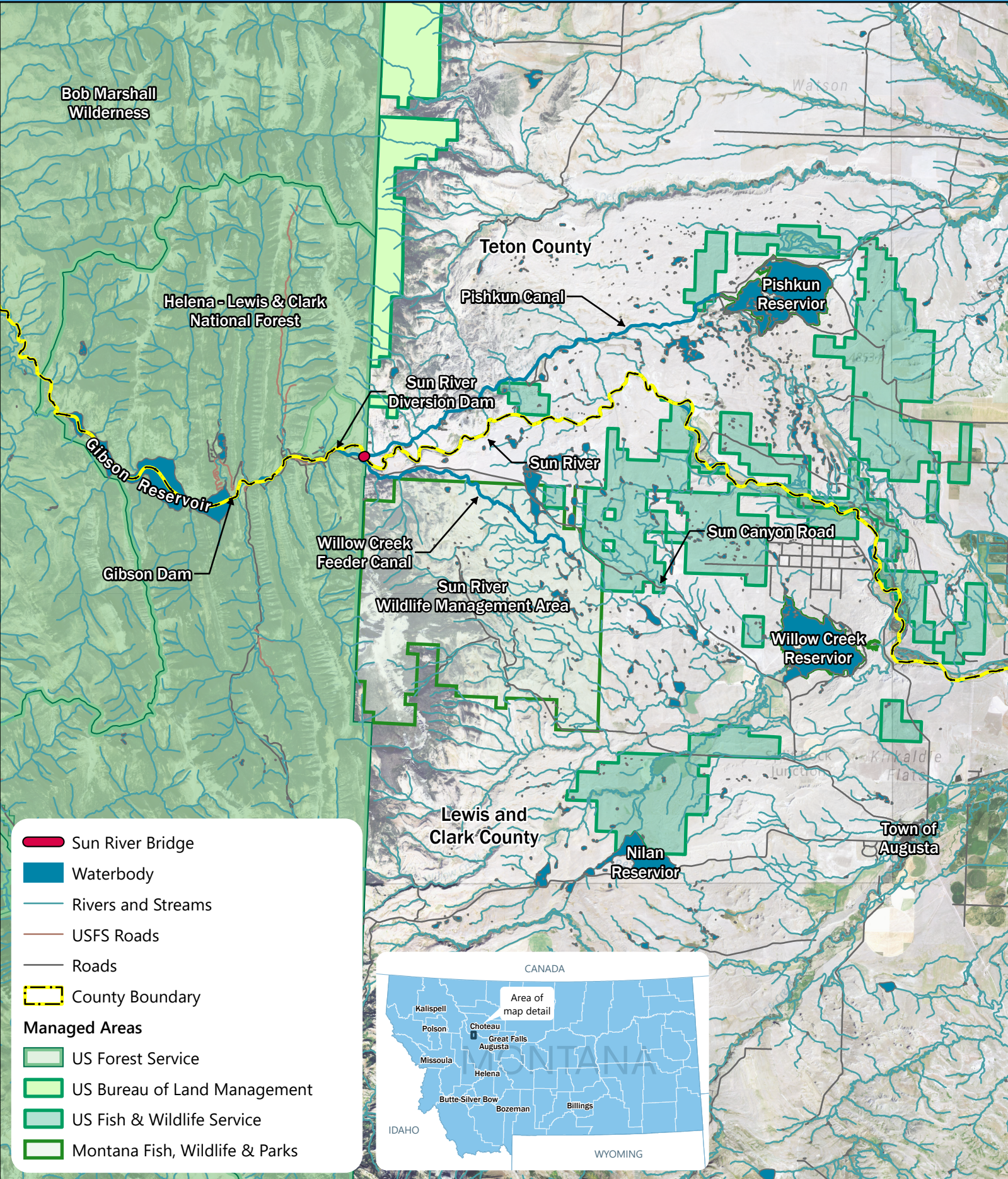

- Sun River Bridge
- Waterbody
- Rivers and Streams
- USFS Roads
- Roads
- County Boundary

**Managed Areas**

- US Forest Service
- US Bureau of Land Management
- US Fish & Wildlife Service
- Montana Fish, Wildlife & Parks

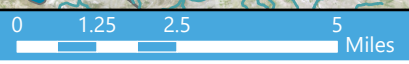
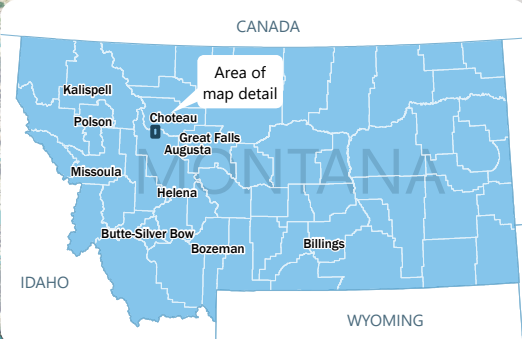

## Project Description

The proposed project consists of replacing the existing single lane bridge spanning the Sun River (Figure 1). The existing bridge provides access to private and public lands and is used by GID to maintain irrigation facilities. The bridge was constructed in 1916 and is in poor condition, and its outdated design poses safety hazards and limitations to users. The new replacement bridge will meet current design and safety standards and will be constructed following an alignment separate from the existing alignment. The new alignment and approach roads will place the bridge at the top edges of the river canyon about 300 feet downstream of the existing bridge. The new bridge is a proposed single lane three span concrete bridge spanning the canyon with piers above the ordinary high water mark (OHWM). Earthwork will be required to construct approximately 1,300 feet of road needed to tie the new alignment with the existing roads. Following construction, the existing bridge would no longer be needed for vehicular access across the Sun River. The existing bridge may be removed or left in place, contingent upon available funding.



The area encompassing all potential project activities is referred to in this report as the *project area*. Project details are provided in the sections below.

### Bridge Details

The new bridge ends would be placed at the top of the river canyon on the west side and slightly below the top edge of the river canyon on the east side. The bridge length is estimated at approximately 455 feet and would consist of three bridge spans composed of prestressed deck bulb tee girders fitted with guard rails, with the concrete girder serving as the driving surface. The main span crossing the river would be 175 feet long, and the two side spans would each be 140 feet long. The bridge deck would be approximately 85 feet above the water surface, with the bottom chord elevation of the proposed bridge located above the lowest elevation of the existing bridge, resulting in result in a hydraulic opening greater than the existing opening. The bridge plans are included in Appendix B.

### Approach Roads

Two new approach roadways totaling approximately 1,300 feet in length with two 12-foot lanes and 2-foot shoulders would connect the new bridge to tie into existing roadways on either side of the Sun River. The grades of the new road would range from 0% to approximately 3%. The approaches would require approximately 20,000 cubic yards of earthwork along with approximately 4.0 acres right-of-way acquisition to allow for the new road connection through public and private property. The gravel-surfaced roadway would be located within a variable right-of-way corridor to encompass the proposed side slopes and roadway drainage ditches. Fill material would be imported to create the roadbed.

## Construction Access and River Diversion

On the east side of the river, construction access would be provided via an existing access route leading from the upper east side of the canyon down to the existing siphon at the east riverbank. Currently, this existing access route is infrequently used by GID to access a siphon release valve on the east bank and provide siphon maintenance. The route would be improved to facilitate construction access and left in place following completion of the project.

From the existing siphon on the east bank of the river, construction access is anticipated across an existing scour hole and along a gravel bar on the eastern shoreline. Reshaping of these features may be required to create a drivable surface for tracked equipment. Access would then need to be developed from the eastern shoreline up the river embankment to the foundation site approximately 10 feet above the OHWM.

To enable construction of the bridge foundation and pier on the western bank of the river, construction access across the river channel would be required since the steep topography of the western canyon walls prevents access. Coordination with GID would be conducted to determine the duration and amount of flow that can be controlled during construction. The normal operating season of the siphon is May through September. It may be possible to keep the siphon open through October to minimize flow in the Sun River.

The contractor may elect to divert river water to one side or the other using a temporary cofferdam constructed from river gravels or other stream diversion materials such as super sacks, water bladders, or shoring to control the river. Diversion would enable a temporary work bridge or buried culverts to be placed across a narrowed river channel for access from the east to the west side of the river. Additionally, a diversion may be used to provide a dry work area on the west riverbank. After access across the river is no longer needed, river diversion and temporary crossing materials would be removed and streambed materials would be restored to pre-existing conditions.

## Vegetation Clearing

Vegetation, consisting of upland habitat, would be cleared within the footprint of the new roadway alignment. Trees on both slopes of the river canyon would be topped to 10 feet vertical distance below the level of the new bridge and 10 feet horizontal distance on each side of the bridge. Vegetation would be flush cut on the existing GID access road on the east bank. A 15- by 15-foot square of vegetation would be removed for each of the bridge pier foundations.

## Bridge Foundations

It is currently anticipated that foundations for the proposed bridge piers would consist of either drilled 10 to 12-foot diameter shafts or driven piles. The two proposed bridge pier foundations would be located approximately 5 to 15 feet outside of the ordinary high water mark (OHWM) of the active channel. The anticipated foundation type and layout would be determined based on the results of subsurface investigations and geotechnical site analysis.



Mechanically stabilized earth (MSE) wall-supported spread footings would be used for the east abutment to reduce the length of the bridge, reduce the earthwork required, and reduce the area of ground disturbance. The MSE wall will be constructed from compacted backfill, soil reinforcements, and facing components (such as wire faced or gabion basket systems) at the top of the slope at the east abutment. Excavation would be required to create a level foundation for the wall, and blasting may be required to construct the bridge abutments due to the presence of shallow bedrock.

## **Bridge Superstructure**

Bridge spans between the abutments and piers would be either a single span or spliced sections. If spliced sections are used, it would be necessary to place temporary shoring towers during construction to support the girders during the splicing operation. Proposed splice locations may be 30 feet towards the river on either side of the intermediate bridge piers. Shoring towers would be created by installing four piles using pile driving or vibratory equipment and placing a cap on top of the piles.

## **Road Obliteration**

The section of road on the west bank between the bridge and the hairpin turn and the section on the east bank between the bridge and the intersection with the private road at the top of the slope would be obliterated. These road sections would be ripped and seeded with a USFS-approved seed mix and blocked to prevent vehicle access.

## **Existing Bridge**

Following construction, the existing bridge would no longer be needed for vehicular access across the Sun River. Two options are under consideration for the existing bridge.

### **Option 1 – Close the Existing Bridge to Vehicular Access and Maintain in Place**

Under this option, the existing bridge and access roadways would remain in place under the ownership of BOR. Concrete barriers and signage would be used to block vehicular access across the bridge due to safety hazards. Routine maintenance would be required to preserve the bridge in place. However, if desired, minor rehabilitation could be conducted including repairs to the deck, abutments, railings, and structural strength to accommodate equestrian and pedestrian loading. Deck repair would include replacing the concrete deck panels with a new wooden deck that would provide a new secure surface for equestrians and pedestrians and reduce the deadload weight on the truss structure, possibly decreasing the extent of truss member strengthening required to support the structure. Additionally, repair or replacement of the abutments would be needed to provide stable bridge support and new railing elements would be needed to provide safe passage for bridge users.

As detailed in the Road Obliteration section above, portions of the existing access roads below the tie-in points with the new access roadways would be abandoned for vehicular use and reclaimed with vegetation. If the existing bridge is allowed to remain in place, the existing roadbeds could be retained for use as a pedestrian trail, with partial obliteration/reclamation to prohibit vehicular use.

## Option 2 – Remove the Existing Bridge

A second option would be to remove the existing bridge. To minimize impacts to the river and the existing siphon buried below the streambed directly under the bridge, only the steel superstructure would be removed. The existing concrete piers would be allowed to remain standing in their current locations and would be maintained in place.

Netting would be placed under the bridge for fall protection and to catch large debris (rivet size and larger). A crane would be used to lift bridge sections as they are cut, and sections would be hauled offsite using a dump truck. A crane would access the work area by driving on the existing camp site access road on the west bank, then driving south along the riverbank. It may be necessary to divert the river to the east to create a drivable surface for the crane. Diversion methods would be the same as the options described for the west bank pier construction.

Option 2 is preferred to minimize ongoing maintenance labor and costs. However, bridge removal is contingent upon available funding. The Montana State Historic Preservation Office (SHPO) has concurred that the bridge is not eligible for listing in the National Register of Historic Places (NRHP) under the Section 106 of the National Historic Preservation Act (NHPA), and therefore no historic impacts would occur if the bridge were removed.

### Staging

All activities associated with construction, including access and staging, would take place within the project area.

## Methods

### Background Information Review

Prior to conducting field investigations, the following data sources were reviewed for information related to wetlands and aquatic features in the survey area and vicinity:

- National Wetland Inventory (NWI) mapping published by the U.S. Fish and Wildlife Service (USFWS 2023)
- Montana Natural Heritage Program (MNHP) wetland and riparian mapping (MNHP 2023)
- Natural Resources Conservation Service (NRCS) soil survey data (NRCS 2023)
- Montana Digital Atlas (Montana State Library 2023)
- Data from USGS Gage 06080900 Sun River Below Diversion Dam Near Augusta MT (USGS 2023)

## OHWM Delineation

The OHWM delineation was conducted on May 23, 2023. The OHWM was identified using guidance from the *National Ordinary High Water Mark Field Delineation Manual for Rivers and Streams: Interim Version* (Gabrielle et al. 2022). This method provides details on evaluation of physical characteristics that correspond to (1) a break in slope, (2) changes in sediment characteristics, and (3) a transition in vegetation type and density. For the Sun River in the survey area sediment indicators were not expected to be reliable because sediment is trapped behind the Diversion Dam, therefore the primary OHWM indicators used were the transition from hydrophytic to terrestrial vegetation types, and a break in slope. Field observations were recorded on a Rapid Ordinary High Water Mark Identification Field Data Sheet.

## Wetland Investigation

To determine whether wetlands were present, biologists evaluated field conditions by walking through the survey area and looking for evidence of hydrophytic vegetation and indicators of wetland hydrology as detailed in the US Army Corps of Engineers (USACE) 1987 *Corps of Engineers Wetlands Delineation Manual* (Environmental Laboratory 1987) and the *Regional Supplement to the Corps of Engineers Wetland Delineation Manual: Western Mountains, Valleys and Coast Region (Version 2)* (USACE 2010).

## Results

### Background Review

MNHP maps of wetlands show freshwater forested-shrub wetlands on the right bank of Sun River upstream of the bridge and survey area. The Sun River is mapped as a riverine perennial stream and Pishkun Canal is mapped as a riverine excavated system. A palustrine scrub-shrub wetland is mapped along the south bank of the canal (Figure 2).

Soils in the survey area are generally rocky, with areas of steep slopes and rock outcrops. NRCS mapping shows four soil types in the survey area (Figure 3). The Tibson-Jonescreek,-Bearmouth complex, is rated as 3 percent hydric. The other soils are rated 0 percent hydric (NRCS 2023a).

Flows in the Sun River are largely regulated by Gibson Dam and the storage and delivery system of the Sun River Irrigation Project, including Pishkun Canal and Willow Creek Feeder Canal. River releases are primarily managed to serve the needs of irrigators however recent focus on water management for fisheries has led to improvement in summer flows in some reaches (MFWP 2019).

The USGS stream gage 06080900 at the Sun River Bridge has flow data between two time periods: 1967 to 1980 and 2016 to present. The gage is located adjacent to the existing bridge. Peak flows are regulated by the dam and generally occur in late May and early June. Peak flows for the most recent period have ranged from a low of 1,110 cfs in 2016 to a high of 10,500 cfs in 2018. During the low flow period flows generally range from 100 to 300 cfs (USGS 2023). Gage data is of limited value to support the OHWM

delineation because it is a highly regulated system therefore Herrera staff relied primarily on field indicators to determine the OHWM.

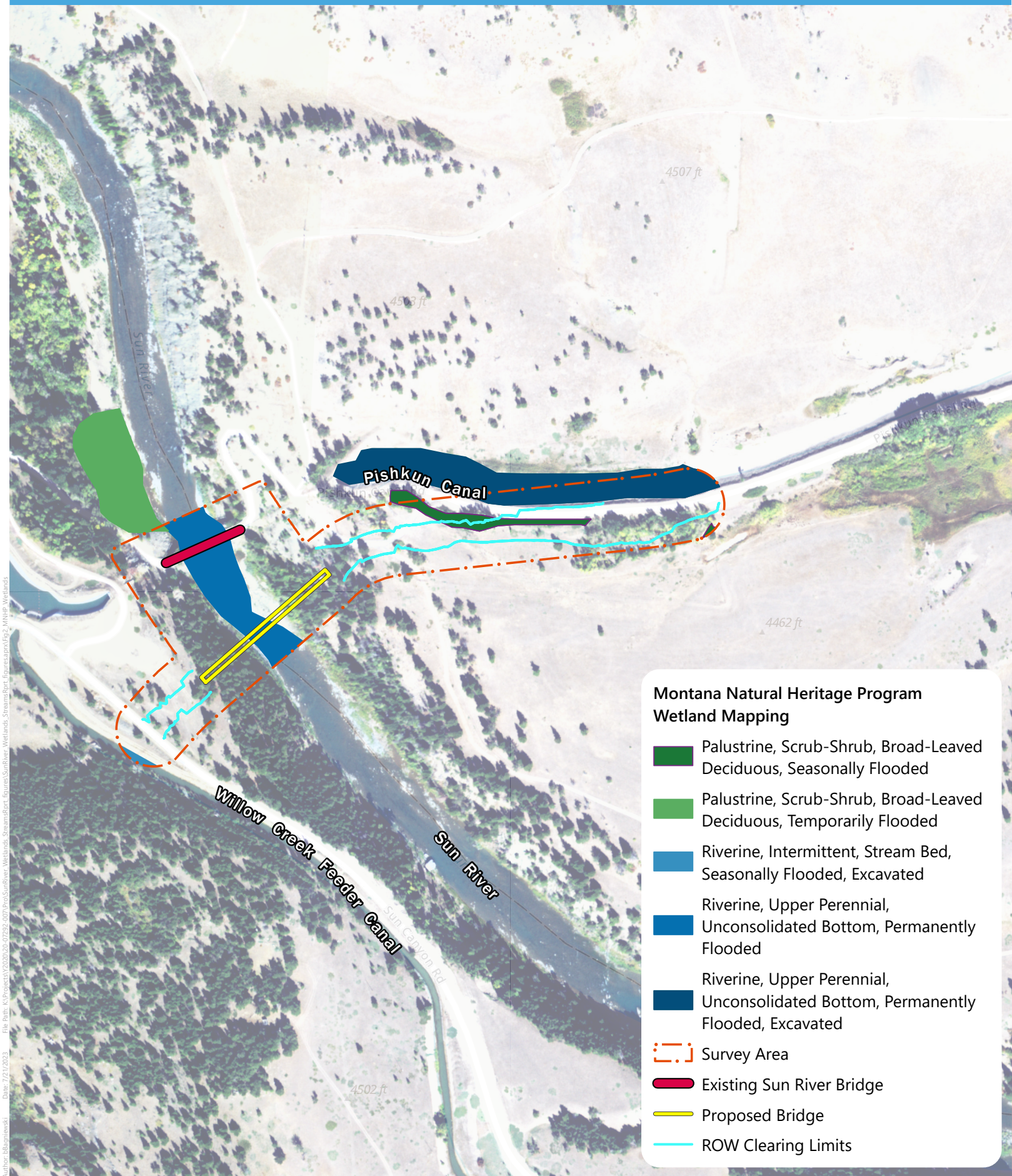

**Montana Natural Heritage Program  
Wetland Mapping**

- Palustrine, Scrub-Shrub, Broad-Leaved Deciduous, Seasonally Flooded
- Palustrine, Scrub-Shrub, Broad-Leaved Deciduous, Temporarily Flooded
- Riverine, Intermittent, Stream Bed, Seasonally Flooded, Excavated
- Riverine, Upper Perennial, Unconsolidated Bottom, Permanently Flooded
- Riverine, Upper Perennial, Unconsolidated Bottom, Permanently Flooded, Excavated
- Survey Area
- Existing Sun River Bridge
- Proposed Bridge
- ROW Clearing Limits

File Path: K:\Projects\2020\00-07292-007\Pro\SunRiver\_Wetlands\_StreamRpt\_Figures\aprx\Fig2\_MNHP\_Wetlands...  
 Date: 7/21/2023  
 Author: bbagniewski

Figure 3.  
NRCS Mapped Soils in the Survey Area.

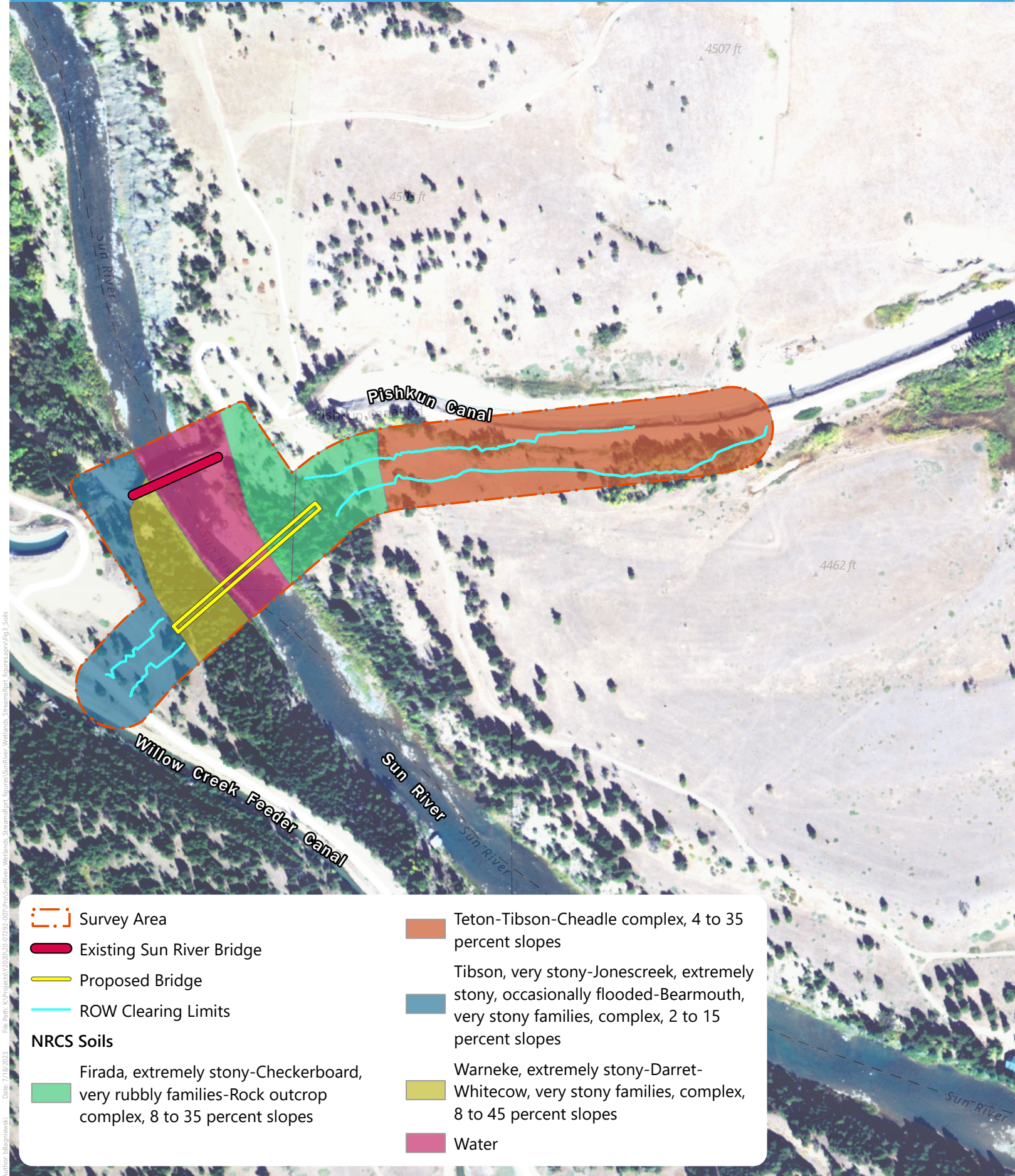

- Survey Area
  - Existing Sun River Bridge
  - Proposed Bridge
  - ROW Clearing Limits
- NRCS Soils**
- Firada, extremely stony-Checkerboard, very rubbly families-Rock outcrop complex, 8 to 35 percent slopes
  - Teton-Tibson-Cheadle complex, 4 to 35 percent slopes
  - Tibson, very stony-Jonescreek, extremely stony, occasionally flooded-Bearmouth, very stony families, complex, 2 to 15 percent slopes
  - Warneke, extremely stony-Darret-Whitecow, very stony families, complex, 8 to 45 percent slopes
  - Water

File Path: K:\Projects\2020\20-07292-007\Proc\SunRiver\_Wetlands\_StreamRpt\_Figures\SunRiver\_Wetlands\_StreamRpt\_Figures\Fig3\_Soils  
 Date: 7/18/2023  
 Author: dbagmlewski

## Field Survey

Herrera staff walked the length of the survey area along the right and left banks of the Sun River. The river was at a relatively high stage (1,850 cfs) on the morning of the site visit, which is above the median for that date (USGS 2023). They observed the low flow channel of the Sun River, indicated by a break in slope that was below the water surface on the day of the site visit. This low flow channel was marked by a distinct drop-off to the channel bed. The observed water level during the site visit was between the edge of the low flow channel and the OHWM. The delineated OHWM is shown on Figure 4 and a field data sheet and photographs for the OHWM delineation is provided in Appendix A. The elevation of the OHWM at the new bridge crossing is 4,371.5 feet.

At the upstream end of the survey area, the OHWM on the right bank (facing downstream) was located at a break in slope at the landward edge of a gravel bar. The dominant plant species on the gravel bar were silverberry (*Elaeagnus commutata*) and willows (*Salix* spp.), species that can tolerate periods of inundation and have flexible stems that can bend during river flooding. The plant community on the slope above the OHWM was dominated by an overstory of trees including Douglas-fir (*Pseudotsuga menziesii*) and black cottonwood (*Populus balsamifera* spp. *trichocarpa*), with Rocky Mountain maple (*Acer glabrum*), and serviceberry (*Amelanchier alnifolia*) in the understory.

The OHWM on the right bank downstream of the bridge was identified based on a break in slope and a change in vegetation from primarily grasses and forbs to forest dominated by Douglas-fir with an understory of creeping juniper (*Juniperus horizontalis*), buffaloberry (*Shepherdia canadensis*), chokecherry (*Prunus virginiana*), bristly gooseberry (*Ribes oxycanthoides*), wax currant (*Ribes cereum*), and Wood's rose (*Rosa woodsii*).

The left bank OHWM upstream of the bridge was located at the edge of a steep bank with exposed tree roots. A clear, continuous break in slope could be seen upstream and downstream at this location.

Downstream of the bridge there was a gravel bar on the left bank vegetated with silverberry, willows and red-osier dogwood (*Cornus sericea*). The OHWM was located landward of the vegetated gravel bar, at a transition between these species and a vegetation community dominated by Douglas-fir, black cottonwood and creeping juniper.

A portion of the southern extent of the OHWM on both banks of the river was estimated based on following the break in vegetation type that was visible in aerial photography. Dense brush made access unsafe in that stretch of the river.

Biologists investigated the wetlands mapped by MNHP to determine if wetland indicators were present. The mapped wetland along the right bank of the Sun River is a gravel bar vegetated with willows and silverberry. A small portion of this mapped wetland overlaps the study area. The dominant vegetation met hydrophytic vegetation criteria, but no hydric soil or wetland hydrology indicators were present, and biologists determined that this feature was not a wetland. The area mapped as a palustrine scrub-shrub wetland south of Pishkun Canal contained a vegetation community dominated by black cottonwood with an understory of shrubs including Wood's rose, common snowberry (*Symphoricarpos albus*) and chokecherry. This vegetation community does not meet the Corps of Engineers criteria for hydrophytic

vegetation, and no indications of wetland hydrology were observed; therefore, this area was determined to be upland.

## Potential Impacts

Activities that could impact aquatic species and habitats during pre-construction and construction of the new bridge are listed below.

The following activities could impact water quality by introducing sediment and/or pollutants:







- Operating equipment in or near the river
- Storing equipment or fueling and maintaining equipment near the river
- Blasting, if dust or rock is allowed to fall into the river
- Placement of temporary fill and culverts for temporary access road, and temporary fill for drilling pads and shoring towers
- Driving across the river if petroleum products come in contact with the water

The following activities could impact aquatic habitat by changing substrate and/or shading the water surface:

- Placement of temporary bridges for access across the river and for construction of the new bridge
- Demolition of the existing bridge (if applicable) could cause debris to fall into the river.





-  Survey Area
-  Existing Sun River Bridge
-  Proposed Bridge
-  ROW Clearing Limits
-  Surveyed OHHW
-  Estimated OHHW
-  Flow Direction

File Path: K:\Projects\2020\20-07292-007\Proc\SunRiver\_Wetlands\_StreamRpt\_Figures\SunRiver\_Wetlands\_StreamRpt\_Figures\Fig4\_DelineatedFeatures...  
 Date: 7/21/2023  
 Author: bBagniewski

## Impact Avoidance and Minimization

Permanent impacts on the Sun River will be avoided by spanning the canyon and placing bridge piers above the 4,371.5-foot elevation of the OHWM. Temporary impacts during construction would be minimized by implementing the following measures:

- Clearly marking construction limits to avoid inadvertent impacts to the Sun River
- Implementing erosion and sediment control measures
- Preventing sediment, petroleum products, chemicals, and other liquids or solid materials from entering the river by locating equipment staging in upland areas away from the river
- Checking equipment daily for leaks and repairing leaks immediately
- Installing containment systems during rock blasting and demolition of the existing bridge, if applicable, to prevent debris and rock from entering the river
- Working during low flow conditions
- Installing the culverts to ensure fish movement is not impeded, if culverts are used for a temporary crossing
- Securing portable bathrooms from wildlife and wind. Cleaning up any portable bathroom spills immediately should they occur

The temporary work bridges, access roads and shoring towers will be removed after construction is complete, and the river channel will be regraded to the original contours. Therefore, no permanent changes to aquatic habitat or channel form would occur.

## References

BOR. 2023. Sun River Project. U.S. Bureau of Reclamation.

<https://www.usbr.gov/projects/index.php?id=420>

Environmental Laboratory. 1987. Corps of Engineers Wetlands Delineation Manual. Technical Report Y 87 1. US Army Corps of Engineers, Waterways Experiment Station, Vicksburg, Mississippi.

Gabrielle C. L. David, Ken M. Fritz, Tracie-Lynn Nadeau, Brian J. Topping, Aaron O. Allen, Patrick H. Trier, Steven L. Kichfski, L. Allan James, Ellen Wohl, and Daniel Hamill. ERDC/CRREL TR-22-26. U.S. Army Corps of Engineers, Engineer Research and Development Center. Wetlands Regulatory Assistance Program. Vicksburg, Mississippi,

GID. 2023. Greenfields Irrigation District. History of Sun River Project. <https://gid-mt.org/about/history/>

MFWP. 2019. Statewide Fisheries Management Plan for the Sun River Drainage. Montana Fish Wildlife and Parks. <https://fwp.mt.gov/binaries/content/assets/fwp/fish/statewide-fisheries-management-plan/part-ii--e.pdf>

NRCS. 2023. Web Soil Survey. Natural Resources Conservation Service.

<https://websoilsurvey.nrcs.usda.gov/app/WebSoilSurvey.aspx>

USGS 2023. Streamflow data from USGS 06080900 Sun River bl Diversion Dam nr Augusta MT.

[https://nwis.waterdata.usgs.gov/nwis/peak?site\\_no=06080900&agency\\_cd=USGS&format=html](https://nwis.waterdata.usgs.gov/nwis/peak?site_no=06080900&agency_cd=USGS&format=html)

USACE. 2010. Regional Supplement to the Corps of Engineers Wetland Delineation Manual: Western Mountains, Valleys, and Coast Region (Version 2.0), eds. J.S. Wakeley, R.W. Lichvar, and C.V. Noble. ERDC/EL TR 10 3. US Army Engineer Research and Development Center, Vicksburg, Mississippi.

USFWS. 2023. National Wetland Inventory. U.S. Fish and Wildlife Service. Wetlands Mapper.

<https://fwsprimary.wim.usgs.gov/wetlands/apps/wetlands-mapper/>



# Appendix A

## OHWM Delineation Data Sheet and Photographs



Project ID #: MT FLAP BOR 2980(1)      Site Name: Sun River Bridge Replacement      Date and Time: May 23, 2023

Location (lat/long): N 47°37'06" and W 112°41'32"      Investigator(s): Susan Wall, Taylor Cross

**Step 1 Site overview from remote and online resources**  
**Check boxes for online resources used to evaluate site:**

gage data       LiDAR       geologic maps  
 climatic data       satellite imagery       land use maps  
 aerial photos       topographic maps       Other: \_\_\_\_\_

**Describe land use and flow conditions from online resources.**  
 Were there any recent extreme events (floods or drought)?  
 No recent flood events. Last extreme flow event was in 2018.

**Step 2 Site conditions during field assessment**  
 First look for changes in channel shape, depositional and erosional features, and changes in vegetation and sediment type, size, density, and distribution. Make note of natural or man-made disturbances that would affect flow and channel form, such as bridges, riprap, landslides, rockfalls etc.

The Sun River in the survey area is in a steep canyon with a narrow strip of riparian vegetation along the river's edge. The left bank of the river located upstream of the existing bridge is rocky and only moderately vegetated. Flows in the Sun River are largely regulated by Gibson Dam and the storage and delivery system of the Sun River Irrigation Project including Pishkun Canal and Willow Creek Feeder Canal.

**Step 3 Check the boxes next to the indicators used to identify the location of the OHWM.**  
**OHWM is at a transition point**, therefore some indicators that are used to determine location may be just below and above the OHWM. From the drop-down menu next to each indicator, select the appropriate location of the indicator by selecting either just below 'b', at 'x', or just above 'a' the OHWM.  
**OHWM.** Go to page 2 to describe overall rationale for location of OHWM, write any additional observations, and to attach a photo log.

Geomorphic indicators	Sediment indicators	Ancillary indicators
<input checked="" type="checkbox"/> <b>Break in slope:</b> x <input checked="" type="checkbox"/> on the bank: x <input type="checkbox"/> undercut bank:      ▼ <input type="checkbox"/> valley bottom:      ▼ <input type="checkbox"/> Other: _____	<input type="checkbox"/> <b>Soil development:</b> <input type="checkbox"/> <b>Changes in character of soil:</b> <input type="checkbox"/> <b>Mudcracks:</b> <input type="checkbox"/> <b>Changes in particle-sized distribution:</b> <input type="checkbox"/> transition from _____ to _____ <input type="checkbox"/> upper limit of sand-sized particles <input type="checkbox"/> silt deposits:	<input type="checkbox"/> <b>Wracking/presence of organic litter:</b> <input type="checkbox"/> <b>Presence of large wood:</b> <input type="checkbox"/> <b>Leaf litter disturbed or washed away:</b> <input type="checkbox"/> <b>Water staining:</b> <input type="checkbox"/> <b>Weathered clasts or bedrock:</b>
<input checked="" type="checkbox"/> <b>Shelving:</b> <input checked="" type="checkbox"/> shelf at top of bank: x <input type="checkbox"/> natural levee: <input type="checkbox"/> man-made berms or levees: <input type="checkbox"/> other berms: _____	<input type="checkbox"/> <b>Vegetation Indicators</b> <input checked="" type="checkbox"/> <b>Change in vegetation type and/or density:</b> x Check the appropriate boxes and select the general vegetation change (e.g., <i>graminoids to woody shrubs</i> ). <b>Describe the vegetation transition looking from the middle of the channel, up the banks, and into the floodplain.</b> <input checked="" type="checkbox"/> vegetation absent to: forbs <input type="checkbox"/> moss to: <input checked="" type="checkbox"/> forbs to: woody shrubs <input type="checkbox"/> graminoids to: <input checked="" type="checkbox"/> woody shrubs to: deciduous trees <input checked="" type="checkbox"/> deciduous trees to: coniferous trees <input type="checkbox"/> coniferous trees to: <input type="checkbox"/> <b>Vegetation matted down and/or bent:</b> <input checked="" type="checkbox"/> <b>Exposed roots below intact soil layer:</b> x	<input type="checkbox"/> <b>Other observed indicators?</b> <b>Describe:</b>   
<input type="checkbox"/> <b>Channel bar:</b> <input type="checkbox"/> shelving (berms) on bar: <input type="checkbox"/> unvegetated: <input type="checkbox"/> vegetation transition (go to veg. indicators) <input type="checkbox"/> sediment transition (go to sed. indicators) <input type="checkbox"/> upper limit of deposition on bar:		<b>Step 4 Is additional information needed to support this determination?</b> <input type="checkbox"/> Yes <input checked="" type="checkbox"/> No If yes, describe and attach information to datasheet:
<input type="checkbox"/> <b>Instream bedforms and other bedload transport evidence:</b> <input type="checkbox"/> deposition bedload indicators (e.g., imbricated clasts, gravel sheets, etc.) <input type="checkbox"/> bedforms (e.g., poofs, riffles, steps, etc.): <input type="checkbox"/> erosional bedload indicators (e.g., obstacle marks, scour, smoothing, etc.)		
<input type="checkbox"/> <b>Secondary channels:</b>		

Project ID #: MT FLAP BOR 2980(1)

**Step 5** Describe rationale for location of OHWM

The OHWM was marked by a transition from shrubs and bare substrate below the OHWM to trees, shrubs and grasses above the OHWM. There was a break in slope at the OHWM, and exposed tree roots at the OHWM line. The river level on the day of the delineation below the OHWM.

Gage data is of limited value to support the OHWM delineation because it is a highly regulated system. For this system sediment indicators were not expected to be reliable because sediment is trapped behind Diversion Dam, therefore the primary OHWM indicators used were the transition from hydrophytic to terrestrial vegetation types, and a break in slope.

**Additional observations or notes**

A low flow channel was observed at a break in slope below the water surface.

Attach a photo log of the site. Use the table below, or attach separately.

Photo log attached?  Yes  No If no, explain why not: \_\_\_\_\_

List photographs and include descriptions in the table below.

Number photographs in the order that they are taken. Attach photographs and include annotations of features.

Photo Number	Photograph description



**OHWM Field Identification Datasheet Instructions and Field Procedure**

**Step 1 Site overview from remote and online resources** **Complete Step 1 prior to site visit.**  
**Online Resources: Identify what information is available for the site. Check boxes on datasheet next to the resources used to assess this site.**

- a. gage data
- b. aerial photos
- c. satellite imagery
- d. LiDAR
- e. topographic maps
- f. geologic maps
- g. land use maps
- h. climatic data (precipitation and temperature)

**Landscape context: Use the online resources to put the site in the context of the surrounding landscape.**

- a. Note on the datasheet under Step 1:**
- i. Overall land use and change if known
  - ii. Recent extreme events if known (e.g., flood, drought, landslides, debris flows, wildfires)
- b. Consider the following to inform weighting of evidence observed during field visit.**
- i. What physical characteristics are likely to be observed in specific environments?
  - ii. Was there a recent flood or drought? Are you expecting to see recently formed or obscured indicators?
  - iii. How will land use affect specific stream characteristics? How natural is the hydrologic regime? How stable has the landscape been over the last year, decade, century?

**Step 2 Site conditions during the field assessment (assemble evidence)**

- a. Identify the assessment area.
- b. Walk up and down the assessment area noting all the potential OHWM indicators.
- c. Note broad trends in channel shape, vegetation, and sediment characteristics.
  - i. Is this a single thread or multi-thread system? Is this a stream-wetland complex?
  - ii. Are there any secondary and/or floodplain channels?
  - iii. Are there obvious man-made alterations to the system?
  - iv. Are there man-made (e.g., bridges, dams, culverts) or natural structures (e.g., bedrock outcrops, Large Wood jams) that will influence or control flow?
- d. Look for signs of recurring fluvial action.
  - i. Where does the flow converge on the landscape?
  - ii. Are there signs of fluvial action (sediment sorting, bedforms, etc.) at the convergence zone?
- e. Look for indicators on both banks. If the opposite bank is not accessible, then look across the channel at the bank.
- f. **In Step 2 of the datasheet** describe any adjacent land use or flow conditions that may influence interpretation of each line of evidence.
  - i. What land use and flow conditions may be affecting your ability to observe indicators at the site?
  - ii. What recent extreme events may have caused changes to the site and affected your ability to observe indicators?

**Step 3a List evidence**

**Assemble evidence by checking the boxes next to each line of evidence:**

- a. If needed, use a separate scratch datasheet to check boxes next to possible indicators, or check boxes of possible indicators in pencil and use pen for final decision.
- b. If using fillable form, then follow the instructions for filling in the fillable form.

*Context is important when assembling evidence. For instance, pool development may be an indicator of interest on the bed of a dry stream, but may not be a useful indicator to take note of in a flowing stream. On the other hand, if the pool is found in a secondary channel adjacent to the main channel, it could provide a line of evidence for a minimum elevation of high flows. Therefore, consider the site context when deciding which indicators provide evidence for identifying the OHWM. Explain reasoning in Step 5.*

**Questions to consider while making observations and listing evidence at a site:**

<b>Geomorphic indicators</b>	<b>Sediment and soil indicators</b>	<b>Vegetation Indicators</b>	<b>Ancillary indicators</b>
Where are the breaks in slope? Are there identifiable banks? Is there an easily identifiable top of bank? Are the banks actively eroding? Are the banks undercut? Are the banks armored? Is the channel confined by the surrounding hillslopes? Are there natural or man-made berms and levees? Are there fluvial terraces? Are there channel bars?	Where does evidence of soil formation appear?  Are there mudcracks present?  Is there evidence of sediment sorting by grain size?	Where are the significant transitions in vegetation species, density, and age?  Is there vegetation growing on the channel bed?  If no, how long does it take for the non-tolerant vegetation to establish relative to how often flows occur in the channel?  Where are the significant transitions in vegetation?  Is the vegetation tolerant of flowing water?  Has any vegetation been flattened by flowing water?	Is there organic litter present?  Is there any leaf litter disturbed or washed away?  Is there large wood deposition?  Is there evidence of water staining?

Are the following features of fluvial transport present?  
*Evidence of erosion: obstacle marks, scour, armoring  
 Bedforms; riffles, pools, steps, knickpoints/headcuts  
 Evidence of deposition: imbricated clasts, gravel sheets, etc.*

**In some cases, it may be helpful to explain why an indicator was NOT at the OHWM elevation, but found above or below. It can also be useful to note if specific indicators (e.g., vegetation) are NOT present. For instance, note if the site has no clear vegetation zonation.**

## OHWM Field Identification Datasheet Instructions and Field Procedure

### Step 3b Weight each line of evidence and weigh body of evidence

Weight each indicator by considering its importance based upon:

**\*Landscape context from Step 1 can help determine the relevance, strength, and reliability of the indicators observed in the field.**

#### a. Relevance:

- i. Is this indicator left by low, high, or extreme flows?

##### Tips on how to assess the indicator relative to type of flow:

*Consider the elevation of the indicator relative to the channel bed.*

*What is the current flow level based on season or nearby gages?*

*Consider the elevation of the indicator relative to the current flow.*

*If the stream is currently at baseflow and indicator is adjacent to that, then it is likely a low flow indicator. The difference between high and extreme flow indicators can sometimes be difficult to determine.*

**\*Information in Chapter 2 of the OHWM field manual provides information on specific indicators which can assist in putting these in context and determining relevance, strength, and reliability.**

- ii. Did recent extreme events and/or land use affect this indicator?

1. Recent floods may have left many extreme flow indicators, or temporarily altered channel form.

Other resources will likely be needed to support any OHWM identification at this site. Field evidence of the OHWM may have to wait for the site to recover from the recent flood.

2. Droughts may cause field evidence of OHWM to be obscured, because there has been an extended time since the last high flow event. There can be overgrowth of vegetation or deposition of material from surrounding landscape that can obscure indicators.

3. Both man-made (e.g., dams, construction, mining activities, urbanization, agriculture, grazing) and natural (e.g., fires, floods, debris flows, beaver dams) disturbances can all alter how indicators are expected to appear at a site. Chapter 6 and Chapter 7 of the OHWM field manual provides specific case-studies that can help in interpreting evidence at these sites.

#### b. Strength:

- i. Is this indicator persistent across the landscape?

1. Look up and downstream and across the channel to see if you see the same indicator at multiple locations.
2. Does the indicator occur at the same elevation as other indicators?

#### c. Reliability:

- i. Is this indicator persistent on the landscape over time? Will this indicator still persist across seasons?

1. This can be difficult to determine for some indicators and may be specific to climatic region (in terms of persistence of vegetation) and history of land use or other natural disturbances.
2. Chapter 2, Chapter 6, and Chapter 7 of the OHWM field manual describes each indicator in detail and provides examples of areas where indicators are difficult to interpret.

#### d. Weigh body of evidence:

- i. Combine weights: integrate the weighted line of evidence (relevance, strength, reliability) of each indicator.
- ii. For each of the observed indicators, which are more heavily weighted? Where do high value indicators co-occur along the stream reach? Do they co-occur at a similar elevation along the banks relative to water surface (or channel bed if there is no water).
- iii. On datasheet, select the indicators used to identify the OHWM. Information in Chapter 2 of the OHWM field manual provides descriptions of specific indicators which can assist in putting these in context and determining relevance, strength, and reliability.

#### e. Take photographs of indicators and attach a log using either page 2 of datasheet or another method of logging photos.

- i. Annotate photos with descriptions of indicators.

### Step 4 Is additional information needed? Are other resources needed to support the lines of evidence observed in the field?

- a. If additional resources are needed, then repeat steps 3a and 3b for the resources selected in Step 1 of assembling, weighting, and weighing evidence collected from online resources. Chapter 5 of the OHWM field manual provides information on using online resources.
- b. Any data collected from online tools have strengths and weaknesses. Make sure these are clear when determining relevance, strength, and reliability of the remotely collected data. Clearly describe why other resources were needed to support the lines of evidence observed in the field, as well as the relevance, strength, and reliability of the supporting data and/or resources.
- c. Attach any remote data and data analysis to the datasheet.

### Step 5 Describe rationale for location of OHWM:

- a. Why do the combination of indicators represent the OHWM?
- b. If there are multiple possibilities for the OHWM, explain why there are two (or more) possibilities. Include any relevant discussion on why specific indicators were not included in the final decision.
- c. If needed, add additional site notes on page 2 of the datasheet under Step 5.

# Sun River Bridge Replacement Project

## OHW M Delineation

### Photographic Log

Photo Number	Photo Description
1	Right bank OHWM upstream of bridge, facing upstream. Silverberry, cottonwood saplings, and willow below OHWM, Douglas-fir and mature cottonwoods above OHWM. Break in slope at OHWM.
2	Right bank OHWM downstream of bridge, facing downstream. Break in slope at OHWM, silverberry below OHWM, Douglas-fir and lodgepole pine above OHWM.,
3	Right bank OHWM downstream of bridge. Silverberry below OHWM, Douglas-fir saplings below OHWM.
4	Left bank OHWM upstream of bridge. Break in slope and exposed roots at OHWM. Bare substrate below OHWM, upland grass and scattered conifers above OHWM.
5	Left bank at the bridge facing upstream. Shelving and change from scattered patches of grass below OHWM to dense grass and shrubs above OHWM.
6	Left bank downstream of the bridge. Break in slope at OHWM. Silverberry and red-osier dogwood below OHWM, Douglas-fir and mature cottonwoods above OHWM.
7	Right bank from bridge facing downstream showing break in vegetation from bare substrate with scattered shrubs below OHWM to conifer forest dominated by Douglas-fir and lodgepole pine above OHWM
8	Left bank from bridge facing downstream showing break in vegetation from willow, red-osier dogwood and silverberry below OHWM to cottonwood and Douglas-fir above OHWM
9	Left bank from bridge facing upstream showing break in vegetation from silverberry below OHWM to rocky slope above OHWM
10	Left bank upstream of bridge looking down showing line of silverberry at edge of low flow channel below the water surface













# Appendix B

## Bridge Plans



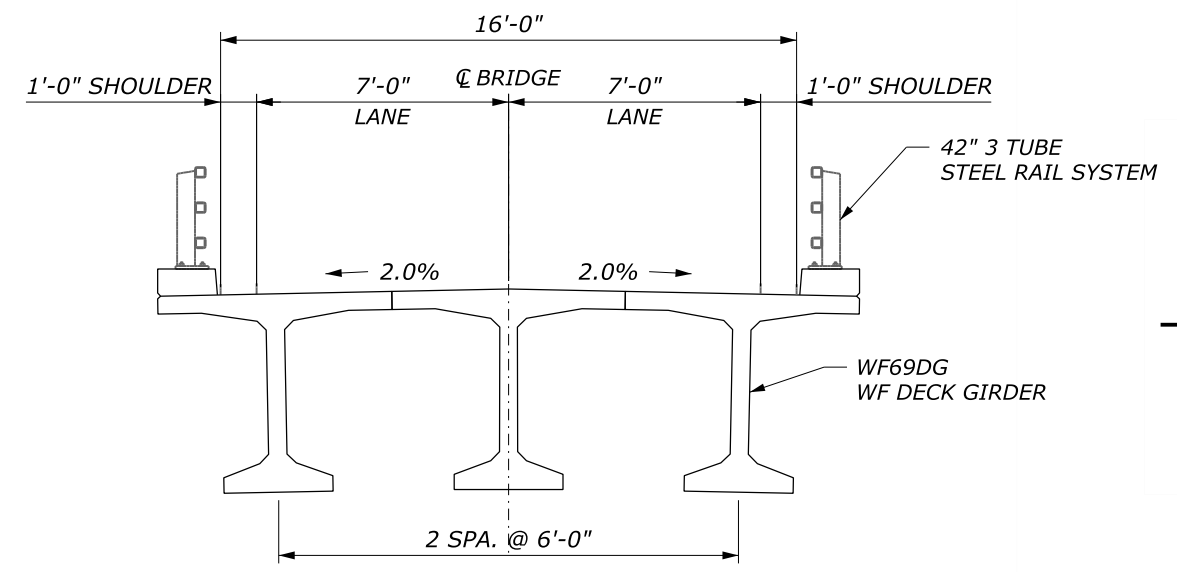

**CONCRETE GIRDER BRIDGE SECTION**  
SCALE: NTS

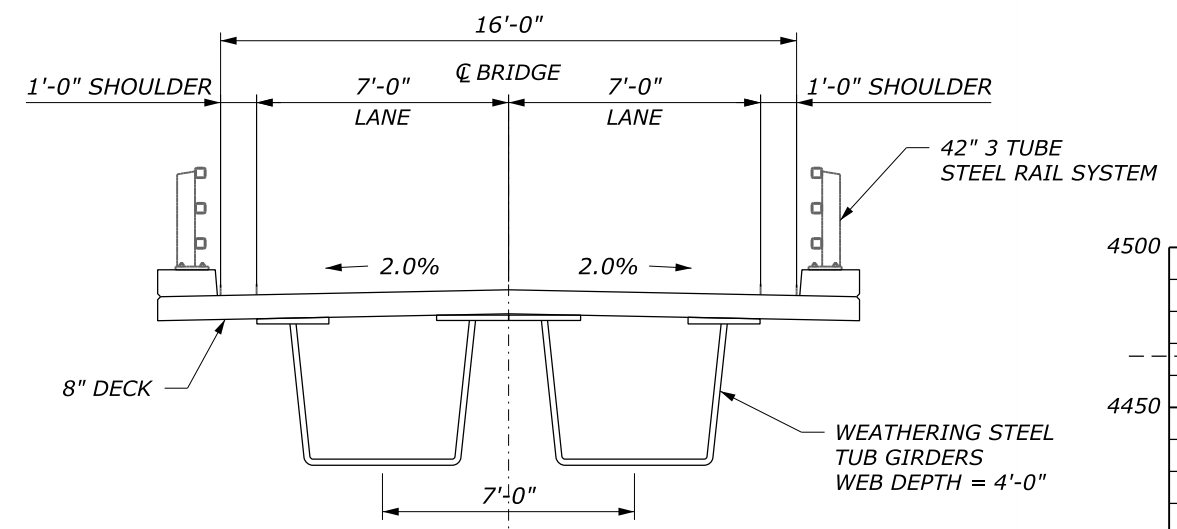

**STEEL TUB GIRDER BRIDGE SECTION**  
SCALE: NTS

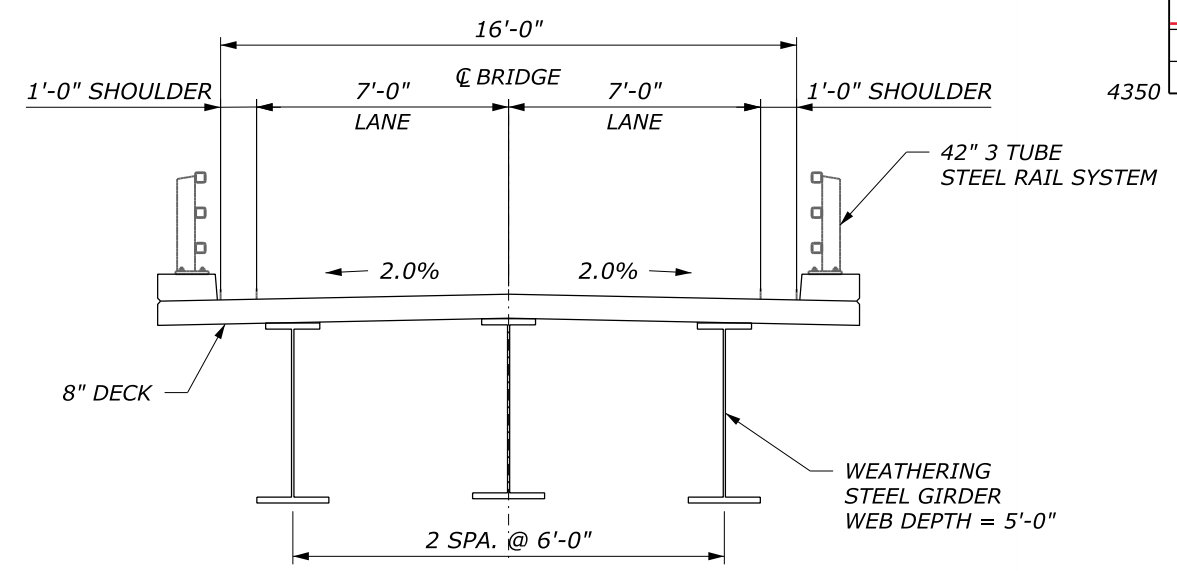

**STEEL GIRDER BRIDGE SECTION**  
SCALE: NTS

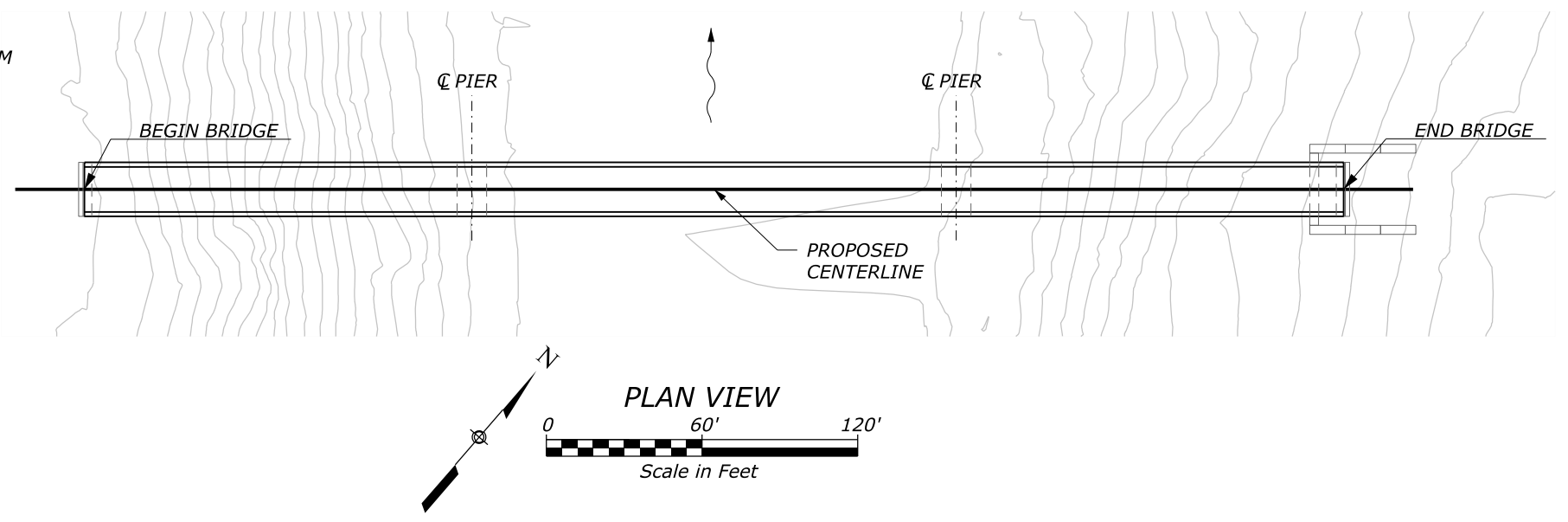

**PLAN VIEW**  
Scale in Feet

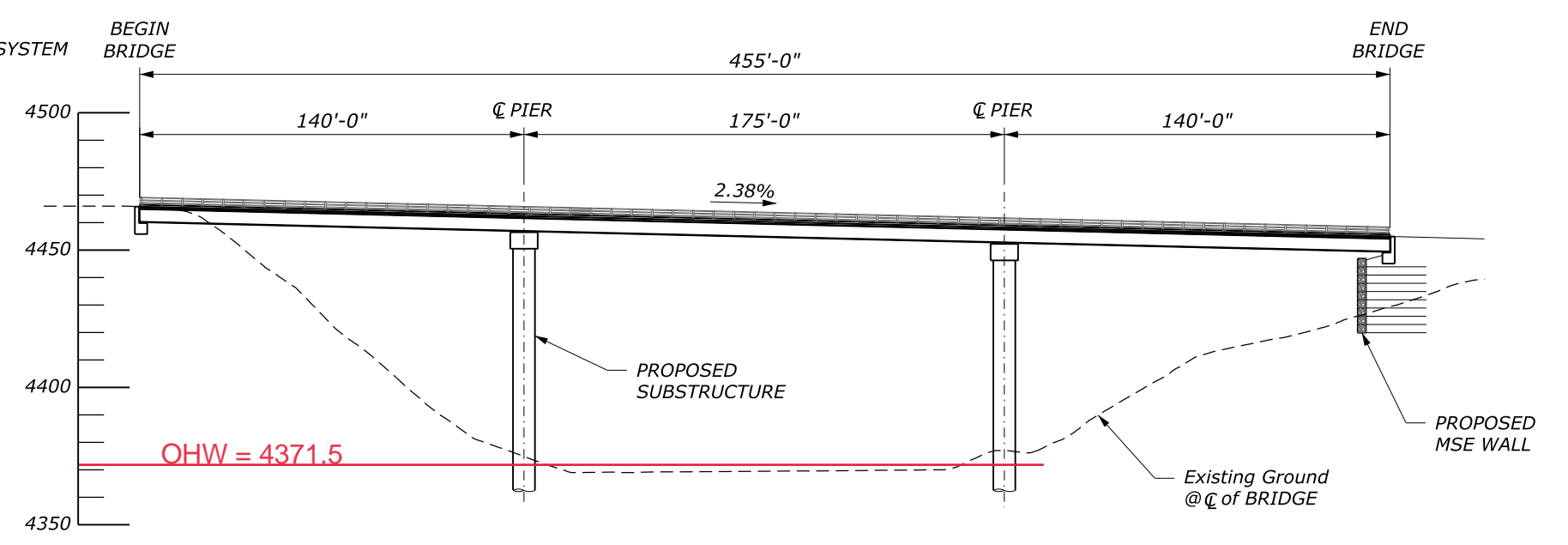

**ELEVATION**  
Scale in Feet

\\parametrix.com\pmx\Port\Projects\Clients\5574-Robert\_Pecchia\274-5574-019\_SunRiverBridgeReplace\99Svcs\CADD\Drawings\274-5574-019-501.dgn (SHEET FILE)  
 16 June 2023 5:01 PM

U.S. DEPARTMENT OF TRANSPORTATION  
 FEDERAL HIGHWAY ADMINISTRATION  
 WESTERN FEDERAL LANDS HIGHWAY DIVISION

U.S. CUSTOMARY DETAIL

**PRELIMINARY LAYOUT  
 SUN RIVER BRIDGE**

REVISIONS:	DATE: 06-2023	DETAIL
		-