



U.S. Department
of Transportation
**Federal Highway
Administration**

1200 New Jersey Ave., SE
Washington, D.C. 20590

June 6, 2016

In Reply Refer To:
HSST-1WZ-342

Henry A. Ross
Plasticade
7700 N. Austin Avenue
Skokie, IL 60077

Dear Mr. Ross:

This letter is in response to your October 5, 2015 request for the Federal Highway Administration (FHWA) to review a roadside safety device, hardware, or system for eligibility for reimbursement under the Federal-aid highway program. This FHWA letter of eligibility is assigned FHWA control number WZ-342 and is valid until a subsequent letter is issued by FHWA that expressly references this device.

Decision

The following devices are eligible, with details provided in the form which is attached as an integral part of this letter:

- Plasticade SSRB800 Sign Stand with Rubber Base

Scope of this Letter

To be found eligible for Federal-aid funding, new roadside safety devices should meet the crash test and evaluation criteria contained in the American Association of State Highway and Transportation Officials' Manual for Assessing Safety Hardware (MASH). However, the FHWA, the Department of Transportation, and the United States Government do not regulate the manufacture of roadside safety devices. Eligibility for reimbursement under the Federal-aid highway program does not establish approval, certification or endorsement of the device for any particular purpose or use.

This letter is not a determination by the FHWA, the Department of Transportation, or the United States Government that a vehicle crash involving the device will result in any particular outcome, nor is it a guarantee of the in-service performance of this device. Proper manufacturing, installation, and maintenance are required in order for this device to function as tested.

This finding of eligibility is limited to the crashworthiness of the system and does not cover other structural features, nor conformity with the Manual on Uniform Traffic Control Devices.

Eligibility for Reimbursement

Based solely on a review of crash test results and certifications submitted by the manufacturer, and the crash test laboratory, FHWA agrees that the device described herein meets the crash test and evaluation criteria of the American Association of State Highway and Transportation Officials' Manual for Assessing Safety Hardware (MASH). Therefore, the device is eligible for reimbursement under the Federal-aid highway program if installed under the range of tested conditions.

Name of system: Plasticade SSRB800 Sign Stand with Rubber Base

Type of system: Work Zone Traffic Control

Test Level: MASH TL-3

Testing conducted by: E-Tech Testing Services, Inc.

Date of request: October 5, 2015

Date initially acknowledged: November 5, 2015

Date of completed package: April 13, 2016

FHWA concurs with the recommendation of the accredited crash testing laboratory as stated within the attached form.

Full Description of the Eligible Device

The device and supporting documentation, including reports of the crash tests or other testing done, videos of any crash testing, and/or drawings of the device, are described in the attached form.

Notice

If a manufacturer makes any modification to any of their roadside safety hardware that has an existing eligibility letter from FHWA, the manufacturer must notify FHWA of such modification with a request for continued eligibility for reimbursement. The notice of all modifications to a device must be accompanied by:

- Significant modifications – For these modifications, crash test results must be submitted with accompanying documentation and videos.
- Non-signification modifications – For these modifications, a statement from the crash test laboratory on the potential effect of the modification on the ability of the device to meet the relevant crash test criteria.

FHWA's determination of continued eligibility for the modified hardware will be based on whether the modified hardware will continue to meet the relevant crash test criteria.

You are expected to supply potential users with sufficient information on design, installation and maintenance requirements to ensure proper performance.

You are expected to certify to potential users that the hardware furnished has the same chemistry,

mechanical properties, and geometry as that submitted for review, and that it will meet the test and evaluation criteria of the MASH.

Issuance of this letter does not convey property rights of any sort or any exclusive privilege. This letter is based on the premise that information and reports submitted by you are accurate and correct. We reserve the right to modify or revoke this letter if: (1) there are any inaccuracies in the information submitted in support of your request for this letter, (2) the qualification testing was flawed, (3) in-service performance or other information reveals safety problems, (4) the system is significantly different from the version that was crash tested, or (5) any other information indicates that the letter was issued in error or otherwise does not reflect full and complete information about the crashworthiness of the system.

Standard Provisions

- To prevent misunderstanding by others, this letter of eligibility designated as FHWA control number WZ-342 shall not be reproduced except in full. This letter and the test documentation upon which it is based are public information. All such letters and documentation may be reviewed upon request.
- This letter shall not be construed as authorization or consent by the FHWA to use, manufacture, or sell any patented system for which the applicant is not the patent holder.
- If the subject device is a patented product it may be considered to be proprietary. If proprietary systems are specified by a highway agency for use on Federal-aid projects: (a) they must be supplied through competitive bidding with equally suitable unpatented items; (b) the highway agency must certify that they are essential for synchronization with the existing highway facilities or that no equally suitable alternative exists; or (c) they must be used for research or for a distinctive type of construction on relatively short sections of road for experimental purposes. Our regulations concerning proprietary products are contained in Title 23, Code of Federal Regulations, Section 635.411.

Sincerely yours,



Michael S. Griffith
Director, Office of Safety Technologies
Office of Safety

Enclosures

Request for Federal Aid Reimbursement Eligibility of Highway Safety Hardware

Submitter	Date of Request:	March 28, 2016	<input checked="" type="radio"/> New <input type="radio"/> Resubmission
	Name:	Henry A. Ross	
	Company:	Plasticade	
	Address:	7700 N. Austin Avenue, Skokie, IL 60077	
	Country:	USA	
To:	Michael S. Griffith, Director FHWA, Office of Safety Technologies		

I request the following devices be considered eligible for reimbursement under the Federal-aid highway program.

Device & Testing Criterion - Enter from right to left starting with Test Level

!-!-!

System Type	Submission Type	Device Name / Variant	Testing Criterion	Test Level
'WZ': Crash Worthy Work Zone Traffic Control Devices	<input checked="" type="radio"/> Physical Crash Testing <input type="radio"/> Engineering Analysis	Plasticade SSRB800 Sign Stand with Rubber Base	AASHTO MASH	TL3

By submitting this request for review and evaluation by the Federal Highway Administration, I certify that the product(s) was (were) tested in conformity with the AASHTO Manual for Assessing Safety Hardware and that the evaluation results meet the appropriate evaluation criteria in the MASH.

Individual or Organization responsible for the product:

Contact Name:	Henry A. Ross	Same as Submitter <input checked="" type="checkbox"/>
Company Name:	Plasticade	Same as Submitter <input checked="" type="checkbox"/>
Address:	7700 N. Austin Avenue, Skokie, IL 60077	Same as Submitter <input checked="" type="checkbox"/>
Country:	USA	Same as Submitter <input checked="" type="checkbox"/>

Enter below all disclosures of financial interests as required by the FHWA 'Federal-Aid Reimbursement Eligibility Process for Safety Hardware Devices' document.

The Plasticade SSRB800 Sign Stand with Rubber Base is the commercial embodiment of intellectual property that is not protected by patents. Plasticade does not pay royalties for sales of the Plasticade SSRB800 Sign Stand with Rubber Base. The Plasticade SSRB800 Sign Stand with Rubber Base was designed and developed by engineers at Plasticade.

Plasticade sponsored certain crash tests of the Plasticade SSRB800 Sign Stand with Rubber Base; such tests were conducted by E-Tech Testing Services, an independent, wholly-owned subsidiary of Trinity Highway. E-Tech Testing Services is an International Standards Organization ("ISO") 17025 accredited laboratory with American Association for Laboratory Accreditation (A2LA) Mechanical Testing certificate 989.01. Full-scale crash testing on the Plasticade SSRB800 Sign Stand with Rubber Base was performed in accordance with testing criteria, as set forth by the Manual for Assessing Safety Hardware ("MASH"; 2009).

PRODUCT DESCRIPTION

- New Hardware or Significant Modification
 Modification to Existing Hardware

The Plasticade® SSRB800 Sign Stand with Rubber Base is a work zone traffic control device used to regulate, warn, and advise road users to traverse a section of highway or street in the proper manner. The sign holder consists of a 19 in x 26 in (483 x 660 mm) rubber base with aluminum vertical support structure. The sign holder was fitted with an industry standard 48 in x 48 in (1220 x 1220 mm) roll-up fabric sign with vertical and horizontal fiberglass supports on back. The overall height of the test article is 81 in (measured to the top corner of the sign) when deployed from its collapsed storage position. Total test article weight was 50 lb. (22.7 kg). No ballast (i.e. sandbags) was added to the test article for this test.

CRASH TESTING

By signature below, the Engineer affiliated with the testing laboratory, agrees in support of this submission that all of the critical and relevant crash tests for this device listed above were conducted to meet the MASH test criteria. The Engineer has determined that no other crash tests are necessary to determine the device meets the MASH criteria.

Engineer Name:	Paul Kruse	
Engineer Signature:	Paul Kruse	 Digitally signed by Paul Kruse Date: 2016.05.24 06:23:21 -07'00'
Address:	3617B Cincinnati Ave, Rocklin, CA	Same as Submitter <input type="checkbox"/>
Country:	United States	Same as Submitter <input type="checkbox"/>

A brief description of each crash test and its result:

Required Test Number	Narrative Description	Evaluation Results
3-70 (1100C)	Test 3-70 was omitted as MASH says it is optional for test articles that weigh less than 220 lbs. (100kg).	Non-Critical, not conducted

Required Test Number	Narrative Description	Evaluation Results
3-71 (1100C)	<p>E-TECH Test 76-0415-001 was MASH Test 3-71 with a 2010 Hyundai Accent weighing 2,482 lbs. impacting the test article at the Critical Impact Angle. It was impacted in both normal and perpendicular orientations. The test articles were placed 19.7 ft. (6 m) apart and the second was turned 90 degrees relative to the first. The test was conducted at a 0 degree angle with the center of the vehicle bumper aligned with the vertical centerline of the test articles. The first impact took place with a normally orientated sign holder at a speed of 61.9 mph. The vehicle bumper impacted the test article approximately 18 in. (457 mm) above ground level. The aluminum support hardware detached from the base of the vertical fiberglass stiffener and rotated onto the vehicle's hood and windshield and initiated minimal windshield cracking. The second impact took place with a perpendicular orientated sign holder at 61 mph. The vehicle bumper contacted the test article approximately 18 in. (457 mm) above ground level. The aluminum support hardware detached from the base of the vertical fiberglass stiffener and then rotated onto the vehicle's hood and windshield. The top edge of the vertical fiberglass sign support made direct contact with the center of the windshield causing moderate windshield deformation. The test article did not penetrate the windshield. The test vehicle used sustained very minor damage. There were small dents in the hood. The windshield was broken however there was no tear in the plastic liner and deformation was 1.0 in (25 mm) and less than the 3 in (76 mm) allowable. There was no deformation of the occupant compartment based upon pre- and post-test measurements. The device was judged to have successfully met all MASH evaluation criteria for Test 3-71 for work zone traffic control devices in both normal and perpendicular orientations</p>	PASS

3-72 (2270P)	Test 3-72, utilizing the 2270P test vehicle, was opted not to be conducted strictly based on the test article performance of the 1100C test vehicle used in Test 3-71. Due to the greater hood height of the 2270P, the detached sign supports are unlikely to travel onto the vehicle's hood and interact with the windshield. Additionally, after a thorough video analysis, the uprights attached to the rubber base fractured/yielded immediately upon impact thus eliminating the possibility of floorboard penetration. The rubber mat itself remained flat on the asphalt foundation and slid a few feet but never came in close proximity to the vehicle's floorboard.	Non-Critical, not conducted
--------------	--	-----------------------------

Full Scale Crash Testing was done in compliance with MASH by the following accredited crash test laboratory (cite the laboratory's accreditation status as noted in the crash test reports.):

Laboratory Name:	E-Tech Testing Services, Inc.	
Laboratory Signature:	Paul Kruse	Digitally signed by Paul Kruse Date: 2016.05.24 06:25:12 -07'00'
Address:	3617B Cincinnati Ave	Same as Submitter <input type="checkbox"/>
Country:	United States	Same as Submitter <input type="checkbox"/>
Accreditation Certificate Number and Dates of current Accreditation period :	A2LA Certificate #0989.01 dated 10/9/2013-11/30/2015 and 11/20/2015-11/30/2017	

Submitter Signature*: **Henry A. Ross**
Digitally signed by Henry A. Ross
 DN: cn=Henry A. Ross, o=Plasticade, ou,
 email=hross@plasticade.com, c=US
 Date: 2016.05.24 10:17:45 -05'00'

Submit Form

ATTACHMENTS

Attach to this form:

- 1) Additional disclosures of related financial interest as indicated above.
- 2) A copy of the full test report, video, and a Test Data Summary Sheet for each test conducted in support of this request.
- 3) A drawing or drawings of the device(s) that conform to the Task Force-13 Drawing Specifications [[Hardware Guide Drawing Standards](#)]. For proprietary products, a single isometric line drawing is usually acceptable to illustrate the product, with detailed specifications, intended use, and contact information provided on the reverse. Additional drawings (not in TF-13 format) showing details that are relevant to understanding the dimensions and performance of the device should also be submitted to facilitate our review.

FHWA Official Business Only:

Eligibility Letter		
Number	Date	Key Words
WZ-342		Work Zone Sign Stand

Normal Orientation



t = 0.000 sec



t = 0.060 sec



t = 0.120 sec

Perpendicular Orientation



t = 0.000 sec



t = 0.060 sec



t = 0.120 sec

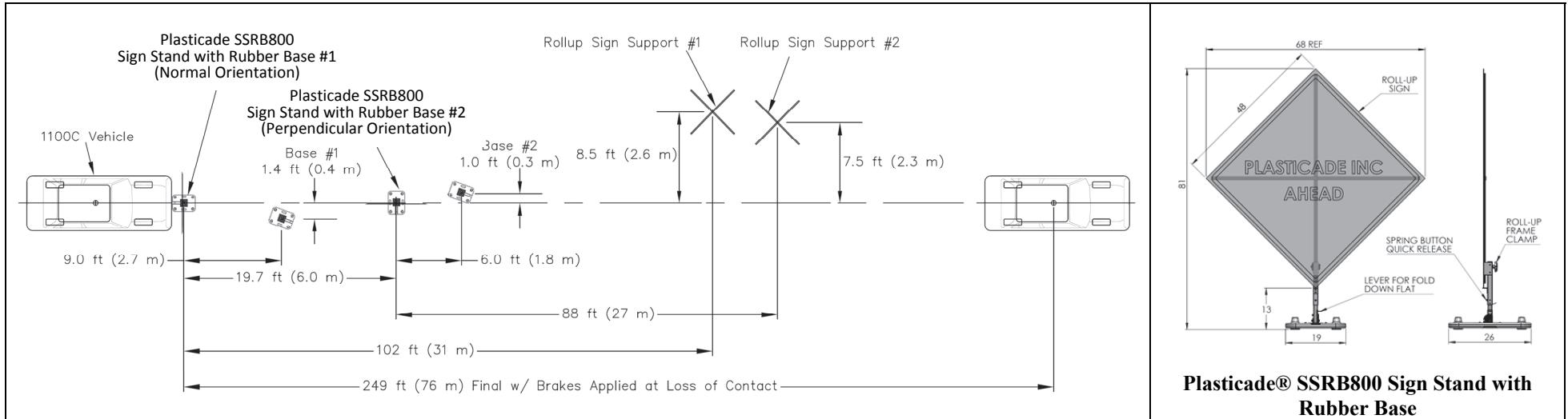

General Information

Test Agency E-TECH Testing Services, Inc.
 Test Designation MASH Test 3-71
 Test No. 76-0415-001
 Date 04/13/2015

Test Article

Type Plasticade
 SSRB800 Sign Stand with Rubber Base
 Dimensions 81 in OA Height x 68 in Wide
 (2057 x 1727 mm)
 Material and Key Elements 45 lb (20.4 kg) Sign Stand with Rubber Base Hardware,
 5 lb (2.3 kg) Roll-up Sign with Fiberglass Supports
 Foundation Type and Condition Asphalt, clean and dry

Test Vehicle

Type Production Model
 Designation 1100C
 Model 2010 Hyundai Accent
 Mass
 Curb 2482 lb (1126 kg)
 Test Inertial 2458 lb (1115 kg)
 Dummy N/A
 Gross Static 2458 lb (1115 kg)

Impact Conditions

Speed (Normal Orientation) 61.9 mi/h (99.6 km/h)
 Speed (Perpendicular Orientation) 61.0 mi/h (98.2 km/h)
 Angle (deg) 0
 Impact Severity (Normal Orientation) 315.3 ft-kip (426.3 kJ)
 Impact Severity (Perpendicular Orientation) .. 305.9 ft-kip (414.8 kJ)

Exit Conditions

Speed (Normal Orientation) 61.0 mi/h (98.2 km/h)
 Speed (Perpendicular Orientation) 60.2 mi/h (96.9 km/h)
 Angle (Deg – veh. c.g.) 0

Occupant Risk Values*

Vehicle Damage

Exterior
 VDS FC-0
 CDC 12FCEW1
 Interior
 VCDI AS0000000
 Maximum Deformation Negligible
 Windshield Moderate damage with no test article penetration

* Not Applicable, device weighs less than 220 lb (100 kg).

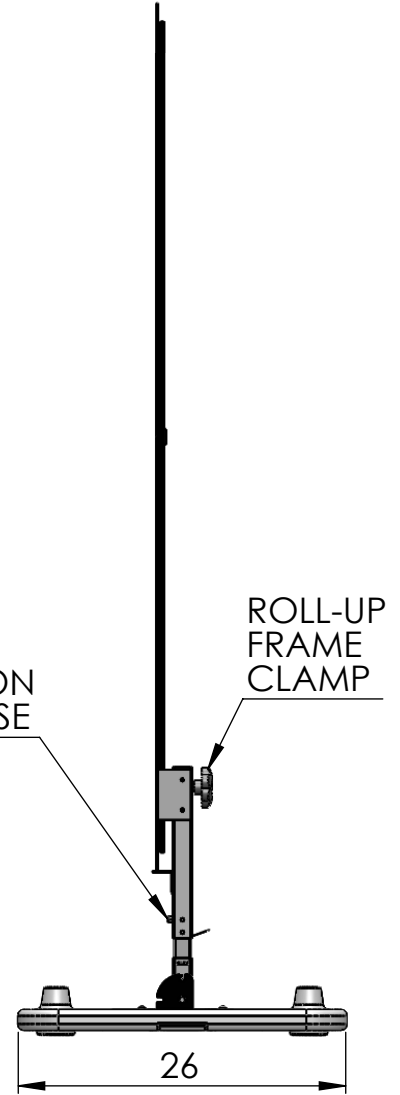
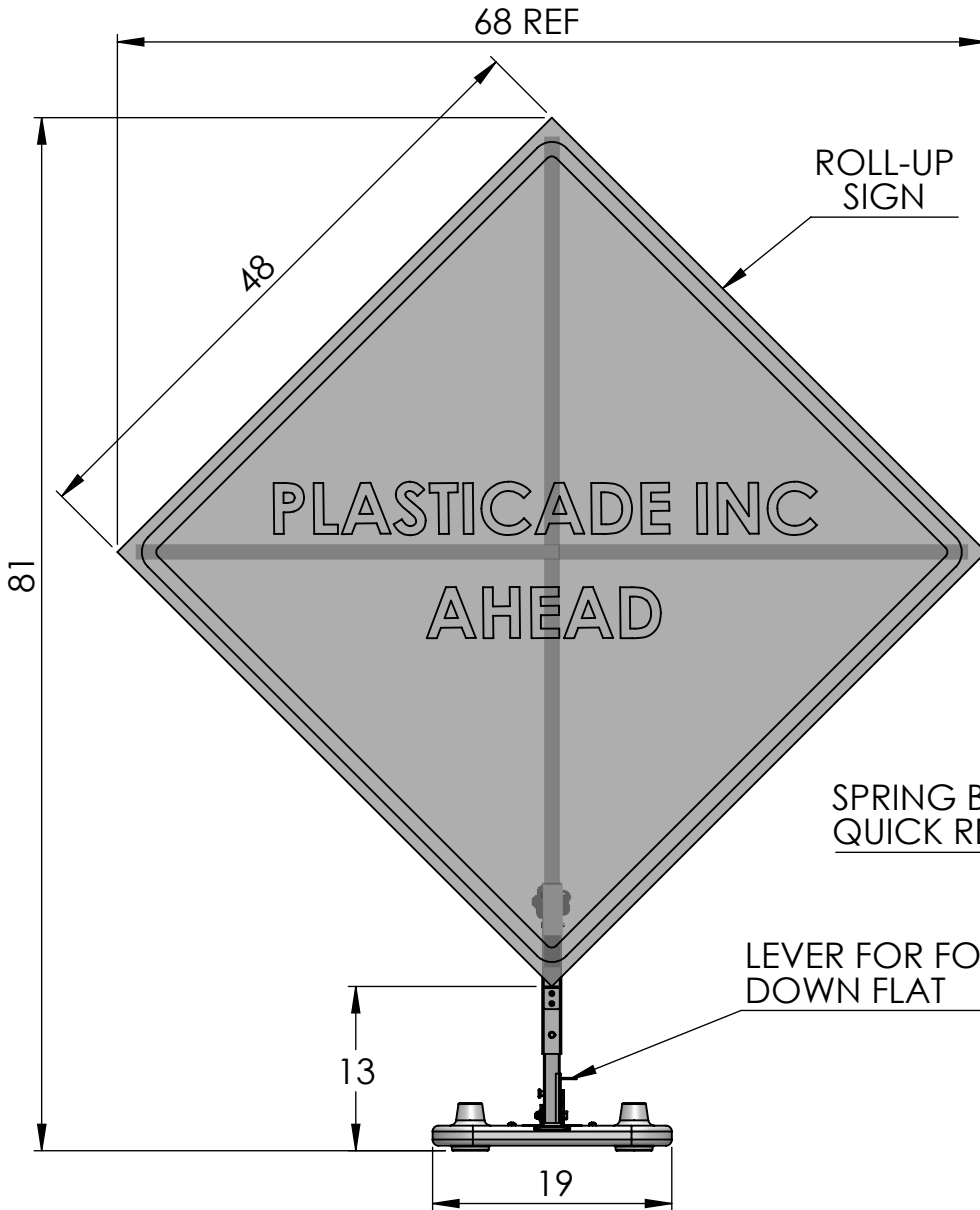
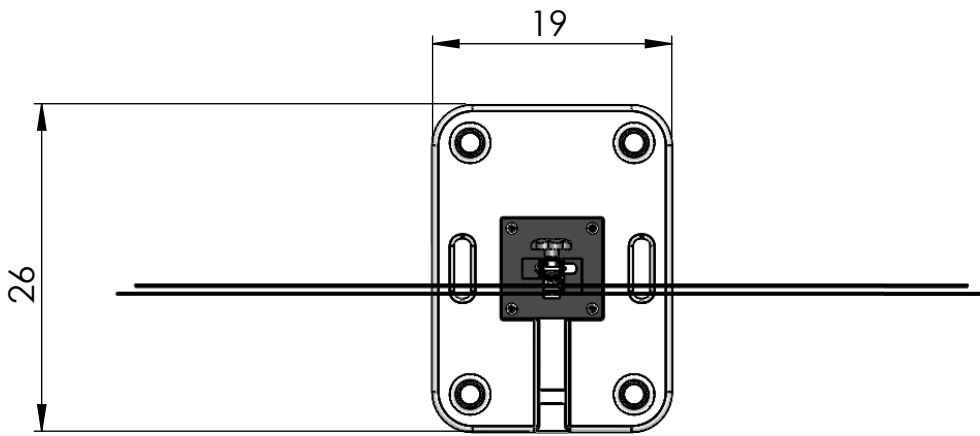

PROPRIETARY AND CONFIDENTIAL
 THE INFORMATION CONTAINED IN THIS DRAWING IS THE SOLE PROPERTY OF PLASTICADE INC. ANY REPRODUCTION IN PART OR AS A WHOLE WITHOUT THE WRITTEN PERMISSION OF PLASTICADE INC. IS PROHIBITED.

	NAME	DATE
DRAWN	SDK	012015
CHECKED		
ENG APPR.		
MFG APPR.		
Q.A.		

PLASTICADE INC.
 7700 N AUSTIN AVE SKOKIE IL
 1-800-470-3300

**RUBBER BASE
 UNIVERSAL SIGN HOLDER**

DO NOT SCALE DRAWING

COMMENTS:

SIZE A	DWG. NO. RB800	REV. B
SCALE: 1:15	SHEET 1 OF 3	

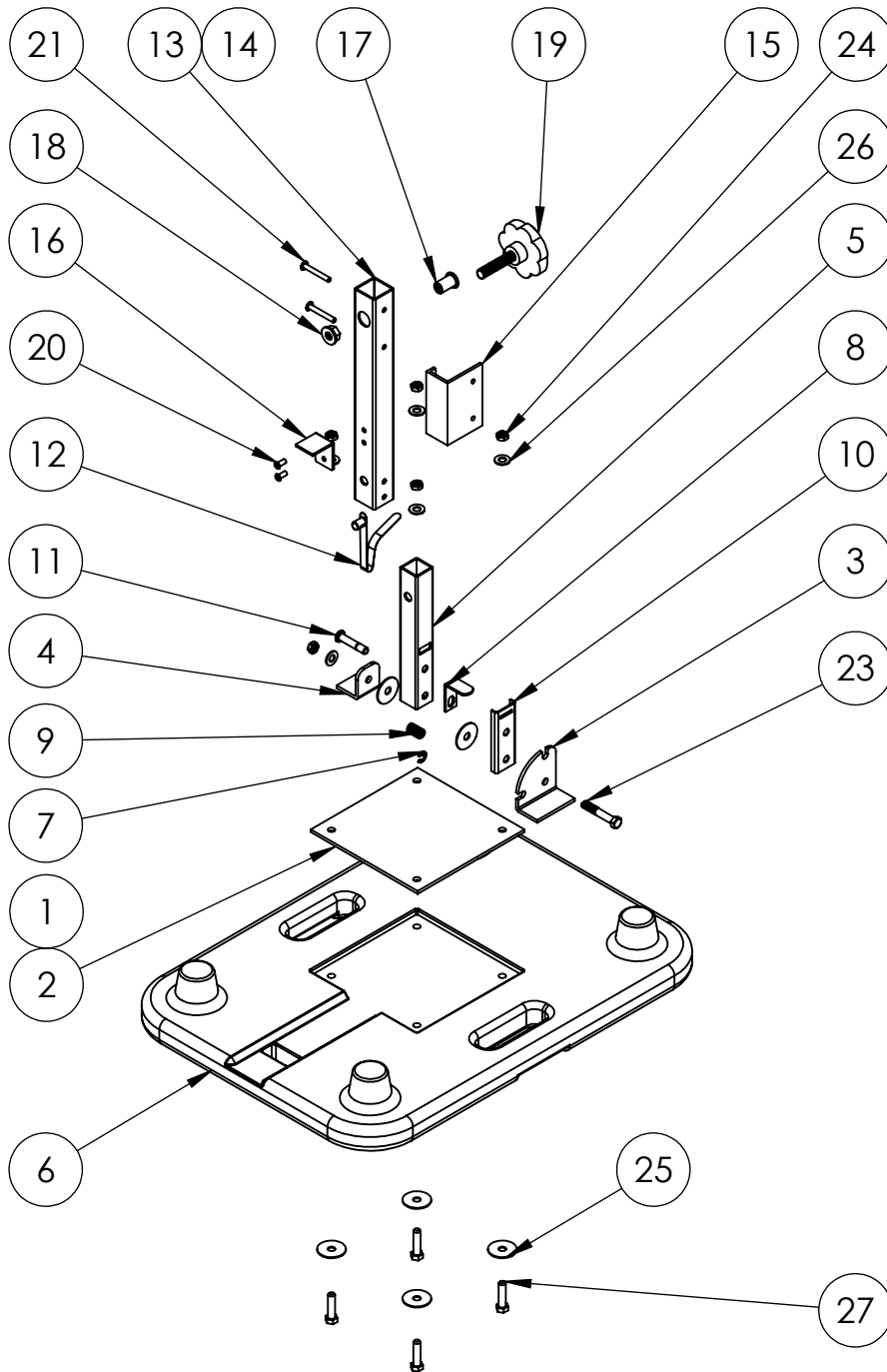

WEIGHT: 45 LBS

PROPRIETARY AND CONFIDENTIAL THE INFORMATION CONTAINED IN THIS DRAWING IS THE SOLE PROPERTY OF PLASTICADE INC. ANY REPRODUCTION IN PART OR AS A WHOLE WITHOUT THE WRITTEN PERMISSION OF PLASTICADE INC. IS PROHIBITED.	NAME	DATE	PLASTICADE INC. 7700 N AUSTIN AVE SKOKIE IL 1-800-470-3300
	DRAWN	SDK 012015	
	CHECKED		
	ENG APPR.		
	MFG APPR.		
DO NOT SCALE DRAWING	COMMENTS:		RUBBER BASE UNIVERSAL SIGN HOLDER
SIZE A	DWG. NO. RB800	REV. B	SCALE:1:10 SHEET 2 OF 3

RB800	80000	80000 RUBBER STAND ASSEMBLY	RSM80000-140619			
ITEM	PART NUMBER	DESCRIPTION	DRAWING NUMBER	MATERIAL	FINISH	Quantity
1	BAR-01-04	80000 BASE HINGE WELDED ASSEMBLY	RSMB507-140926			1
2	BAR-01	RUBBER BASE STEEL PLATE	RSMB503-140331	STEEL 1018	POWDER COAT	1
3	BAR-01-01	RUBBER BASE LEG PLATE A - LATCH	RSMB504-140331	STEEL 1018	POWDER COAT	1
4	BAR-01-02	RUBBER BASE LEG PLATE B	RSMB505-140331	STEEL 1018	POWDER COAT	1
5	BAR-01-03	80000 RUBBER BASE ALUM POST	RSMB506-140926	AL 6360 T5	ALUMINUM	1
6	BAR	RUBBER BASE	RSMB500-140331	RUBBER	RUBBER	1
7	LLA-CLIP	LEG LEVER CLIP	RSML165-140331	STEEL		1
8	LLA-LEVER	LEG LEVER	RSML163-140331	STEEL 1018	ZINC PLATE	1
9	LLA-SPRING	LEVER SPRING	RSML164-140331	STEEL		1
10	LLA-32-V2	LEG LEVER PIN COVER ALUM LEGS	RSML166-140331	STEEL 1018	ZINC PLATE	1
11	LLA-PIN	LEVER PIN	RSML162-140331	STEEL 1018	ZINC PLATE	1
12	MSB-12	MAST SPRING BUTTON 12 MM	MSB-12-02	STEEL	ZINC PLATE	1
13	SA-URSH	UNIVERSAL ROLL UP SIGN HOLDER	RSMA300-140902			1
14	SA-URSH-01	SA-URSH-01 TUBE 38MM X 340MM X 2.5 WALL	RSMA301-140926	AL 6360 T5	ALUMINUM	1
15	SA-URSH-02	SA-URSH-02 CLAMP J-PLATE	RSMA302-140811	STEEL 1018	ZINC PLATE	1
16	SA-URSH-03	SA-URSH-03 SUPPORT BRACKET	RSMA303-140811	STEEL 1018	ZINC PLATE	1
17	SA-URSH-04	SA-URSH-04 RIV NUT	RSMA304-140331	STEEL	ZINC PLATE	1
18	SA-URSH-05	SA-URSH-05 FLANGE NUT 12 X 1.75 MM THREAD	RSMA305-140331	STEEL	ZINC PLATE	1
19	SA-URSH-06	SA-URSH-06 KNOB BOLT	RSMA306-140902	PLASTIC/STEEL	ZINC PLATE	1
20	RIVET-POP 6MM	RIVET FOR SUPPORT BRACKET	SEE RIVET MASTER	STEEL	ZINC PLATE	2
21	RIVET-USH-46	RIVET 6MM X 46MM LONG	SEE RIVET MASTER	STEEL	ZINC PLATE	2
22	HARDWARE					
23	LLA-BOLT	3/8-16 X 2-1/4 HEX BOLT PLATED	BOLT/NUT SHEET	STEEL GRADE 5	ZINC PLATE	1
24	LLA-NLN	NUT HEX NYLON LOCK 3/8-16	BOLT/NUT SHEET	STEEL	ZINC PLATE	5
25	LLA-LWASHER	WASHER .41 I.D. 1.5 O.D X .065	SEE WASHER SHEET	STEEL	ZINC PLATE	5
26	LLA-WASHER	WASHER .410 ID 1.00 OD X .07	WASHER SHEET	STEEL	ZINC PLATE	6
27	RB-BOLT	3/8-16 X 1-1/2 HEX BOLT PLATED	BOLT/NUT SHEET	STEEL	ZINC PLATE	4

PROPRIETARY AND CONFIDENTIAL THE INFORMATION CONTAINED IN THIS DRAWING IS THE SOLE PROPERTY OF PLASTICADE INC. ANY REPRODUCTION IN PART OR AS A WHOLE WITHOUT THE WRITTEN PERMISSION OF PLASTICADE INC. IS PROHIBITED.	NAME	DATE	PLASTICADE INC. 7700 N AUSTIN AVE SKOKIE IL 1-800-470-3300	
	DRAWN	SDK		11/20/14
	CHECKED			
	ENG APPR.			
	MFG APPR.			
Q.A.			RUBBER BASE UNIVERSAL SIGN HOLDER	
DO NOT SCALE DRAWING	COMMENTS:			
SIZE	DWG. NO.	REV.		
A	RB800	A		
SCALE:1:10			SHEET 3 OF 3	



E-TECH Testing Services
3617B Cincinnati Avenue A Trinity Highway
Rocklin, CA 95765 Products Company
Phone: 916-644-9102
916-645-3653

April 13, 2016

Plasticade
7700 N. Austin Ave.
Skokie, IL 60077

Attn: Henry Ross, Director of Government Relations

Ref: SSRB800 Sign Stand with Rubber Base

Subj: Test Vehicle Hood Height (MASH 1100C)

To Henry Ross:

On April 13, 2015, E-TECH Testing Services conducted E-TECH Test No. 76-0415-001 on your SSRB800 Sign Stand. MASH Test 3-71 was conducted on sign stands equipped with a roll-up sign and a rubber base with an overall height of 81 inches. The purpose of this letter is to clarify a discrepancy concerning the test vehicle's measured hood height as reported in E-TECH Test Report No. 434.

Per Table 4-1 in MASH, the hood height measurement for an 1100C test vehicle should be 60 ± 10 cm. Our test vehicle hood height was measured at 73 cm which is outside of the specified range. Due to the rounded shaped of the test vehicles hood, which is representative of most vehicles six years old or newer, there is some ambiguity on where to take the measurement. The test vehicle used in this test was fully representative of an 1100C vehicle per MASH specifications. This is an ongoing topic discussed amongst several crash testing laboratories.

E-TECH thoroughly reviewed the videos of this crash test and confidently conclude that the hood height discrepancy does not affect the test article to test vehicle interaction whatsoever. The critical vehicle dimensions are the front bumper height and hood length. The front bumper initiates the release of the upper sign section and the hood length determines the initial point of contact of the test vehicle's windshield. Minor variations in hood heights produce an inconsequential affect to the test results of this test.

Please feel free to contact us directly if there are additional questions and/or comments regarding this judgment.

Best regards,

Paul L. Kruse, PE
E-TECH Manager
paul.kruse@trin.net