



U.S. Department
of Transportation

Federal Highway
Administration

1200 New Jersey Ave., SE
Washington, D.C. 20590

December 23, 2015

In Reply Refer To:
HSST/B-255A

Ms. Karla Lechtenberg
Midwest Roadside Safety Facility
130 Whittier Research Center
2200 Vine Street
Lincoln, NE 68583-0853

Dear Ms. Lechtenberg:

This letter is in response to your May 11, 2015 request for the Federal Highway Administration (FHWA) to review a roadside safety device, hardware, or system for eligibility for reimbursement under the Federal-aid highway program. This FHWA letter of eligibility is assigned FHWA control number B-255A and is valid until a subsequent letter is issued by FHWA that expressly references this device.

Decision

The following devices are eligible, with details provided in the form which is attached as an integral part of this letter:

- Low-Deflection Portable Concrete Barrier Version 2

Scope of this Letter

To be found eligible for Federal-aid funding, new roadside safety devices should meet the crash test and evaluation criteria contained in the American Association of State Highway and Transportation Officials' Manual for Assessing Safety Hardware (MASH). However, the FHWA, the Department of Transportation, and the United States Government do not regulate the manufacture of roadside safety devices. Eligibility for reimbursement under the Federal-aid highway program does not establish approval, certification or endorsement of the device for any particular purpose or use.

This letter is not a determination by the FHWA, the Department of Transportation, or the United States Government that a vehicle crash involving the device will result in any particular outcome, nor is it a guarantee of the in-service performance of this device. Proper manufacturing, installation, and maintenance are required in order for this device to function as tested.

This finding of eligibility is limited to the crashworthiness of the system and does not cover other structural features, nor conformity with the Manual on Uniform Traffic Control Devices.

Eligibility for Reimbursement

Based solely on a review of crash test results and certifications submitted by the manufacturer, and the crash test laboratory, FHWA agrees that the device described herein meets the crash test and evaluation criteria of the American Association of State Highway and Transportation Officials' Manual for Assessing Safety Hardware (MASH). Therefore, the device is eligible for reimbursement under the Federal-aid highway program if installed under the range of tested conditions.

Name of system: Retrofit, Low-Deflection Portable Concrete Barrier Version 2

Type of system: Longitudinal Barrier

Test Level: MASH Test Level 3

Testing conducted by: Midwest Roadside Safety Facility

Task Force 13 Designator: SWC20a-b

Date of request: May 11, 2015

Date initially acknowledged: May 28, 2015

Date of completed package: August 21, 2015

Full Description of the Eligible Device

The device and supporting documentation, including reports of the crash tests or other testing done, videos of any crash testing, and/or drawings of the device, are described in the attached form.

Notice

If a manufacturer makes any modification to any of their roadside safety hardware that has an existing eligibility letter from FHWA, the manufacturer must notify FHWA of such modification with a request for continued eligibility for reimbursement. The notice of all modifications to a device must be accompanied by:

- Significant modifications – For these modifications, crash test results must be submitted with accompanying documentation and videos.
- Non-signification modifications – For these modifications, a statement from the crash test laboratory on the potential effect of the modification on the ability of the device to meet the relevant crash test criteria.

FHWA's determination of continued eligibility for the modified hardware will be based on whether the modified hardware will continue to meet the relevant crash test criteria.

You are expected to supply potential users with sufficient information on design, installation and maintenance requirements to ensure proper performance.

You are expected to certify to potential users that the hardware furnished has the same chemistry,

mechanical properties, and geometry as that submitted for review, and that it will meet the test and evaluation criteria of the MASH.

Issuance of this letter does not convey property rights of any sort or any exclusive privilege. This letter is based on the premise that information and reports submitted by you are accurate and correct. We reserve the right to modify or revoke this letter if: (1) there are any inaccuracies in the information submitted in support of your request for this letter, (2) the qualification testing was flawed, (3) in-service performance or other information reveals safety problems, (4) the system is significantly different from the version that was crash tested, or (5) any other information indicates that the letter was issued in error or otherwise does not reflect full and complete information about the crashworthiness of the system.

Standard Provisions

- This letter provides a AASHTO/ARTBA/AGC Task Force 13 designator that should be used for the purpose of the creation of a new and/or the update of an existing Task Force 13 drawing for posting on the on-line 'Guide to Standardized Highway Barrier Hardware' currently referenced in AASHTO Roadside Design Guide.
- To prevent misunderstanding by others, this letter of eligibility designated as FHWA control number B-255A shall not be reproduced except in full. This letter and the test documentation upon which it is based are public information. All such letters and documentation may be reviewed upon request.
- This letter shall not be construed as authorization or consent by the FHWA to use, manufacture, or sell any patented system for which the applicant is not the patent holder.
- If the subject device is a patented product it may be considered to be proprietary. If proprietary systems are specified by a highway agency for use on Federal-aid projects: (a) they must be supplied through competitive bidding with equally suitable unpatented items; (b) the highway agency must certify that they are essential for synchronization with the existing highway facilities or that no equally suitable alternative exists; or (c) they must be used for research or for a distinctive type of construction on relatively short sections of road for experimental purposes.

Our regulations concerning proprietary products are contained in Title 23, Code of Federal Regulations, Section 635.411.

Sincerely yours,

A handwritten signature in blue ink that reads "Michael S. Griffith". The signature is written in a cursive style with a large, stylized "M" and "G".

Michael S. Griffith
Director, Office of Safety Technologies
Office of Safety

Enclosures

Request for Federal Aid Reimbursement Eligibility Of Highway Safety Hardware

Submitter	Date of Request:	May 11, 2015	<input checked="" type="radio"/> New <input type="radio"/> Resubmission
	Name:	Karla Lechtenberg	
	Company:	Midwest Roadside Safety Facility	
	Address:	130 Whittier Research Center, 2200 Vine Street, Lincoln, NE 68583-0853	
	Country:	USA	
	To:	Michael S. Griffith, Director FHWA, Office of Safety Technologies	

I request the following devices be considered eligible for reimbursement under the Federal-aid highway program.

Help

System Type	Submission Type	Device Name / Variant	Testing Criterion	Test Level
'B': Barriers (Roadside, Median, Bridge Railings)	<input checked="" type="radio"/> Physical Crash Testing <input type="radio"/> FEA & V&V Analysis <input type="radio"/> Engineering Analysis	Retrofit, Low-Deflection Portable Concrete Barrier Version 2	AASHTO MASH	TL3

By submitting this request for review and evaluation by the Federal Highway Administration, I certify that the product(s) was (were) tested in conformity with the AASHTO Manual for Assessing Safety Hardware and that the evaluation results meet the appropriate evaluation criteria in the MASH.

Identification of the individual or organization responsible for the product:

Contact Name:	Karla Lechtenberg	Same as Submitter <input checked="" type="checkbox"/>
Company Name:	Midwest Roadside Safety Facility	Same as Submitter <input checked="" type="checkbox"/>
Address:	130 Whittier Research Center, 2200 Vine Street, Lincoln, NE 68583-	Same as Submitter <input checked="" type="checkbox"/>
Country:	USA	Same as Submitter <input checked="" type="checkbox"/>

PRODUCT DESCRIPTION

<input checked="" type="radio"/> New Hardware	<input type="radio"/> Modification to Existing Hardware	
<p>The Low-Deflection Portable Concrete Barrier Version 2 system (SWC20b) is comprised of Portable F-shape Concrete Barrier Element (SWC09) joined with the Portable Concrete Barrier Connector Pins with or without the retainer bolt (FMW02 or FMW03) and stiffened by attachment of a steel cap across each joint of the barrier system and the addition of tubular beams on both faces of the barrier. The system is not anchored to the roadway surface and is designed for use with PCB segments (SWC09) placed in a straight line or large-radius curves where the design tolerances can accommodate the small angles between adjacent barrier segments. A 42-in. long, 10-gauge, ASTM A1011 Grade 50 bent steel cap was centered across each joint and through-bolted to the barriers with either four 12 3/4-in. long, ASTM A449 bolts with nuts (FBX24b) and washers (FWC24a) on both sides of the barrier or four 14-in. long, ASTM A449 threaded straight anchor studs with nuts (FRS24b) and washers (FWC24a) on both sides of the barrier. A 153 3/6-in. long, 5-in. x 5-in. x 3/16-in. ASTM A500 Grade B steel tube was welded to the steel cap on both sides of the barrier. The steel tubes were spliced at the center of each Portable F-shape Concrete Barrier Element (SWC09). Each splice contained a 22-in. long, 4 1/2-in. x 4 1/2-in. x 1/2-in. U-shape bent ASTM A572 Grade 50 steel splice insert which was placed inside the end of each of the adjoining tubes. The tube splices were bolted together on both the front and back sides with four 6 1/2-in. long, 3/4-in. diameter Grade 5 bolts with nuts (FBX20a) and washers (FWC20a) under the head of the bolt and the nut. A 12-in. long, 4-in. x 3-in. x 3/8-in., ASTM A529 Grade 50 L-bracket was welded to the bottom side of the steel tubes at 13 1/2-in. from the each end of the steel tubes. The L-brackets were through-bolted to the barriers with either two 13-in. long, ASTM A449 bolts with nuts (FBX20b) and washers (FWC20a) on both sides of the barrier or two 14 1/4-in. long, ASTM A449 threaded straight anchor studs with nuts (FRS20b) and washers (FWC20a) on both sides of the barrier. The bolts and threaded anchor studs should not have more than 1/2 in. of length exposed past the end of the nut.</p>		

CRASH TESTING

A brief description of each crash test and its result:

Required Test Number	Narrative Description	Evaluation Results
3-10 (1100C)	<p>In test no. 7069-3 found in FHWA report nos. FHWA-RD-93-058 and FHWA-RD-93-064, a rigid, F-shape bridge rail was successfully impacted by a small car weighing 1,800 lb at 60.1 mph and 21.4 degrees according to the American Association of State Highway and Transportation Officials (AASHTO) Guide Specifications for Bridge Railings. Rigid New Jersey safety shape barriers struck by small cars have been shown to meet safety performance standards.</p> <p>In test no. 2214NJ-1 found in MwRSF report no. TRP-03-177-06, a New Jersey safety shape barrier was impacted by a passenger car weighing 2,579 lb at 60.8 mph and 26.1 degrees according to the TL-3 standards set forth in MASH. Temporary New Jersey safety shape concrete median barriers have experienced only slight barrier deflections when impacted by small cars and behave similarly to rigid barriers. Therefore, the 1100C passenger car test was deemed unnecessary for this system.</p>	WAIVER REQUESTED

Required Test Number	Narrative Description	Evaluation Results
3-11 (2270P)	<p>The results of test no. RDTCB-2 conducted on August 9, 2013 are found in MwRSF report no. TRP-03-295-14. A 4,978-lb pickup truck with a simulated occupant seated in the right-front seat, impacted the low-deflection PCB version 2 system offset 24 in. from the edge of a simulated bridge deck at a speed of 64.8 mph and at an angle of 25.4 degrees. At 0.192 sec after impact, the vehicle became parallel to the system with a speed of 58.4 mph. At 0.684 sec, the vehicle exited the barrier system at a speed of 47.9 mph and at an angle of 7.2 degrees. The vehicle was smoothly redirected. After exiting the system, the vehicle yawed back toward the system and came to rest in contact with the barrier.</p> <p>Exterior vehicle damage was moderate. Interior occupant compartment deformations were minimal with a maximum of 1 in., consequently not violating the limits established in MASH. Damage to the barrier was also moderate, consisting of vehicle contact marks on the front face of the PCB segments and steel tubes, concrete spalling, concrete cracking, and permanent deformation of the steel tube rails. The additional attachment points for the steel tubes successfully stiffened the PCB system and transmitted the impact loads more effectively to adjacent barrier segments to engage more of the barrier system. However, due to the amount of flexural cracking and damage to the PCB segments, the flexural capacity of the PCB segments was exceeded which limited the systems effectiveness in reducing barrier deflections. The maximum lateral dynamic barrier deflection was 40.7 in., which included tipping of the barrier at the top surface. The working width of the system was 51.9 in. All barrier segments were safely retained on the edge of the bridge deck. All occupant risk measures were within the recommended limits, and the test vehicle showed no tendency to roll over.</p>	PASS
3-20 (1100C)	Not Applicable	WAIVER REQUESTED
3-21 (2270P)	Not Applicable	WAIVER REQUESTED

Full Scale Crash Testing was done in compliance with MASH by the following accredited crash test laboratory (cite the laboratory's accreditation status as noted in the crash test reports.):

Laboratory Name:	Midwest Roadside Safety Facility	
Laboratory Contact:	Karla Lechtenberg	Same as Submitter <input checked="" type="checkbox"/>
Address:	130 Whittier Research Center, 2200 Vine Street, Lincoln, NE 68583-0853	Same as Submitter <input checked="" type="checkbox"/>
Country:	USA	Same as Submitter <input checked="" type="checkbox"/>
Accreditation Certificate Number and Date:	A2LA Certificate Number: 2937.01, Valid to November ^{December} 30, 2015	

Submitter Signature*: Karla
Lechtenberg

Digitally signed by Karla Lechtenberg
DN: cn=Karla Lechtenberg, o=Midwest
Roadside Safety Facility (MwRSF) Inc.,
email=kpolivka2@unl.edu, c=US
Date: 2015.05.11 11:25:13 -0500

Submit Form

ATTACHMENTS

Attach to this form:

- 1) A copy of the full test report, video, and a Test Data Summary Sheet for each test conducted in support of this request.
- 2) A drawing or drawings of the device(s) that conform to the Task Force-13 Drawing Specifications [Hardware Guide Drawing Standards]. For proprietary products, a single isometric line drawing is usually acceptable to illustrate the product, with detailed specifications, intended use, and contact information provided on the reverse. Additional drawings (not in TF-13 format) showing details that are key to understanding the performance of the device should also be submitted to facilitate our review.

FHWA Official Business Only:

Eligibility Letter		AASHTO TF13	
Number	Date	Designator	Key Words



SCOPE OF ACCREDITATION TO ISO/IEC 17025:2005

MIDWEST ROADSIDE SAFETY FACILITY (MwRSF)¹
 University of Nebraska-Lincoln
 4800 NW 35th Street
 Lincoln, NE 68524
 Ms. Karla Lechtenberg Phone: 402 472 9070

MECHANICAL

Valid To: December 31, 2015

Certificate Number: 2937.01

In recognition of the successful completion of the A2LA evaluation process, accreditation is granted to this laboratory to perform the following tests:

Tests

Test Methods²

Full-Scale Vehicle Crash Tests of Highway Safety Features

NCHRP Report 350; MASH; EN 1317

Full-Scale Vehicle Crash Tests of Perimeter Protection Systems and Access Control Devices

ASTM F2656; SD-STD-02.01 Revision A

Bogie and Pendulum Dynamic Tests of Highway Safety Features

Non-Standard Test Method: Dynamic Testing of Steel Post and Rigid Foundation; Non-Standard Test Method: Dynamic Testing of Post in Soil; Non-Standard Test Method: Dynamic Testing of Spacer Blocks

Crushable Nose Pendulum/Bogie Testing for Breakaway Supports

Non-Standard Test Method: Dynamic Testing of Breakaway Supports; AASHTO Breakaway Poles and Supports; NCHRP Report 350

On the following types of products, materials, and/or structures: Metal, Wood, Concrete and Plastic Structures, Components of Structures, Fasteners, and Roadway Pavements.

¹ Administrative office located at: 2200 Vine Street, 130 Whittier Building, Lincoln, NE 68583-0853.

² This laboratory meets A2LA R104 – *General Requirements: Accreditation of Field Testing and Field Calibration Laboratories* for these tests.

Peter Mlynar
 Page 1 of 1



Accredited Laboratory

A2LA has accredited

MIDWEST ROADSIDE SAFETY FACILITY (MWRSF)

Lincoln, NE

for technical competence in the field of

Mechanical Testing

This laboratory is accredited in accordance with the recognized International Standard ISO/IEC 17025:2005 *General requirements for the competence of testing and calibration laboratories*. This accreditation demonstrates technical competence for a defined scope and the operation of a laboratory quality management system (refer to joint ISO-ILAC-IAF Communiqué dated 8 January 2009).



Presented this 31st day of December 2013.

A handwritten signature in black ink, reading "Peter Abney".

President & CEO
For the Accreditation Council
Certificate Number 2937.01
Valid to December 31, 2015

August 27, 2015

Subject: Financial Interest Statement

Dear Will:

This letter is intended to be a disclosure of any financial interest that the Midwest Roadside Safety Facility (MwRSF) and its employees have in the **Retrofit, Low-Deflection Portable Concrete Barrier Version 1 and Version 2** for which we are requesting a letter of eligibility on behalf of the state departments of transportation participating in the Midwest States Regional Pooled Fund Program, specifically Wisconsin Department of Transportation.

MwRSF's financial interests are as follows:

- (i) No compensation, including wages, salaries, commissions, professional fees, or fees for business referrals;
- (ii) Consulting relationships consist of answering design and implementation questions from the member states;
- (iii) Research funding or other forms of research support include continuing to fund the Midwest States Regional Pooled Fund Program as well as state departments of transportation funding individual research projects with MwRSF;
- (iv) No patents, copyrights, or other intellectual property interests for this system;
- (v) No licenses or contractual relationships for this system; and
- (vi) No business ownership and investment interests for this system.

If you need any further information or clarification, please feel free to contact Dr. Ron Faller or myself.

Sincerely,



Karla A. Lechtenberg
Research Associate Engineer

cc: Ronald K. Faller, Ph.D., Director and Research Associate Professor

December 21, 2015

Subject: Small Car Test Waiver Information

Dear Will:

This letter is intended to address the request by FHWA for additional information pertaining to vehicle stability of the small car in regards to the **Retrofit, Low-Deflection Portable Concrete Barrier Version 2** for which we are requesting a letter of eligibility on behalf of the state departments of transportation participating in the Midwest States Regional Pooled Fund Program, specifically Wisconsin Department of Transportation.

In test no. 7043-2 found in Volume II – Appendices of NCHRP Project 22-6 (final report NCHRP 318), a rigid, New Jersey shape concrete barrier was successfully impacted by a small car weighing 1,722 lb at 59.9 mph and 21.9 degrees similar to the standards set forth in NCHRP 350. In test no. 7043-12 found in Volume II – Appendices of NCHRP Project 22-6 (final report NCHRP 318), a rigid, New Jersey shape concrete barrier was successfully impacted by a small car weighing 1,695 lb at 61.6 mph and 20.1 degrees similar to the standards set forth in NCHRP 350. In test no. 7069-3 found in FHWA report nos. FHWA-RD-93-058 and FHWA-RD-93-064, a rigid, F-shape bridge rail was successfully impacted by a small car weighing 1,800 lb at 60.1 mph and 21.4 degrees according to the American Association of State Highway and Transportation Officials (AASHTO) Guide Specifications for Bridge Railings.

During all three tests, the small car climbed the face of the barrier and became airborne. Although the small cars were airborne for a brief period, the vehicle remained upright and was smoothly redirected. The geometry of the F-shape exhibited improved vehicle stability characteristics when compared to the New Jersey shape even though both barrier shapes allow the small car to climb the face of the barrier.

Further, in test no. 2214NJ-1 found in MwRSF report no. TRP-03-177-06, a rigid, New Jersey safety shape barrier was successfully impacted by a passenger car weighing 2,579 lb at 60.8 mph and 26.1 degrees according to the TL-3 standards set forth in MASH. The 1100C vehicle once again climbed the face of the barrier and became airborne, but remained upright and was smoothly redirected. Therefore, based on the above noted tests, the 1100C passenger car test was believed to be unnecessary for this system.

If you need any further information or clarification, please feel free to contact Dr. Ron Faller, Bob Bielenberg, or myself.

Sincerely,

A handwritten signature in cursive script that reads "Karla A. Lechtenberg".

Karla A. Lechtenberg
Research Associate Engineer

cc: Ronald K. Faller, Ph.D., Director and Research Associate Professor
Bob Bielenberg, Research Associate Engineer

December 14, 2015

Subject: Small Car Test

Dear Will:

This letter is intended to address the question pertaining to concerns for occupant compartment intrusion with the 1100C vehicle raised by FHWA in regards to the **Retrofit, Low-Deflection Portable Concrete Barrier Version 1 and Version 2** for which we are requesting a letter of eligibility on behalf of the state departments of transportation participating in the Midwest States Regional Pooled Fund Program, specifically Wisconsin Department of Transportation.

The top rail height for the low-deflection PCB system is 29". This height was based on the 27" and 28" heights of the previously tested box beam roadside and median barrier systems, respectively. The height was adjusted to 29" due on connection and interference issues with the PCB reinforcement. This height was not believed to be an issue as the height of the small car (1100C) vehicle window is generally over 31". Thus, the height of the box beam rail is lower than the A-pillar, windshield, and side-window structures, and the potential for the box beam to intrude or cause excessive damage in these areas is minimal.

Additionally, the box beam is mounted on an F-shape PCB. Typically, small cars that interact with the toes of F-shape barriers tend to climb the barrier and roll away from the face of the barrier. This motion would further reduce the potential for damage to the A-pillar or other areas above the door frame by the box beam. The box beam railing used in the system is a continuous element that is spliced longitudinally similar to other box beam and tubular bridge rail designs. The box beam is anchored to the PCB at the cap over the PCB joint and at the mid-section of the barrier. This prevents the tubes from disengaging from the PCB and becoming an intrusion hazard. The increased impact loading of the 2270P impacts would have indicated any potential for the tubes to disengage or separate.

Previous testing with small cars on an identically similar system does not exist, but similar testing appears to indicate that it is not a safety concern. Previous testing of box-beam systems or tubular bridge rails, as summarized below, has not indicated that occupant compartment deformation of the small cars due to the tubes is an issue.

1. In test no. 473160-8, a box-beam transition to two tube bridge rail was evaluated according to NCHRP 350 Test Level 3 (TL-3) with the 820C vehicle. The transition had a top rail height of 29". This test passed NCHRP 350 with a

similar rail height and a much stiffer tubular rail configuration than the low-deflection PCB system which deflects approximately 40". While the angle of the NCHRP 350 test was 20 degrees rather than the 25 degrees required by MASH, this test would suggest that there is minimal concern for occupant compartment deformation for MASH test designation no. 3-10.

2. In test no. 7202-5, a box beam median barrier terminal was evaluated according to NCHRP 350 TL-3 with the 820C vehicle. The box beam median terminal had a rail height of 28". The small car was safely redirected and no occupant compartment concerns arose. Again, the tests were not identical to the low-deflection PCB system in terms of impact conditions and the rail height is slightly lower by 1". However, it further indicates that occupant compartment intrusion would be a concern.

Therefore, based on a comparison of similar previous testing and engineering analysis of the box-beam rail height mounted on the low-deflection PCB system relative to the vehicle structure, we do not believe that occupant compartment deformation or intrusion concerns warranted conducting MASH test designation no. 3-10, the 1100C small car vehicle.

Lastly, this letter is intended to further clarify the Not Applicable statement in the Narrative Description for Required Test Number 3-20 and 3-21 in the Request for Federal Aid Reimbursement Eligibility of Highway Safety Hardware form submitted. Not Applicable means that test numbers 3-20 and 3-21 are not applicable for this type of system.

If you need any further information or clarification, please feel free to contact Dr. Ron Faller, Bob Bielenberg, or myself.

Sincerely,



Karla A. Lechtenberg
Research Associate Engineer

cc: Ronald K. Faller, Ph.D., Director and Research Associate Professor
Bob Bielenberg, Research Associate Engineer

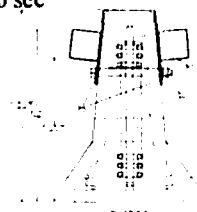
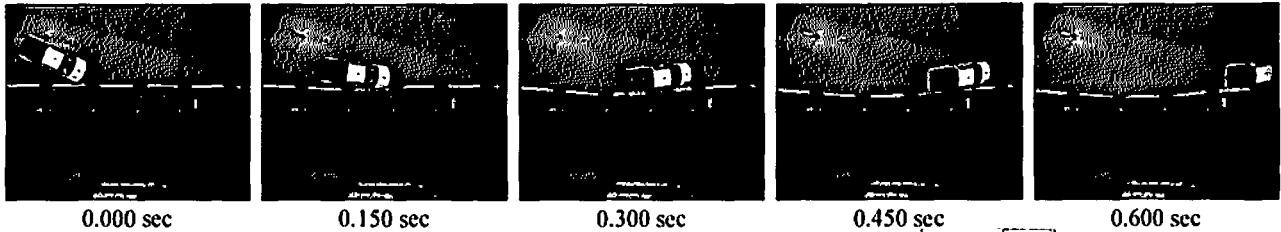

- Test Agency MwRSF
- Test Number RDTCB-2
- Date August 8, 2013
- MASH Test Designation 3-11
- Test Article Stiffened Temporary Concrete Barrier
- Total Length 204 ft 7¹/₁₆ in. (62.4 m)
- Key Component – Concrete Barrier
 - Length 150 in. (3,810 mm)
 - Base Width 22.5 in. (572 mm)
 - Height 32 in. (813 mm)
- Key Component – Box-Beam
 - Length 153⁷/₁₆ in. (3,891 mm)
 - Dimension 5 in. x 5 in. (127 mm x 127 mm)
 - Wall Thickness 1/16 in. (5 mm)
- Soil Type N/A
- Vehicle Make /Model Dodge Ram 1500 Quad Cab
 - Curb 4,887 lb (2,217 kg)
 - Test Inertial 4,978 lb (2,258 kg)
 - Gross Static 5,143 lb (2,333 kg)
- Impact Conditions
 - Speed 64.8 mph (104.3 km/h)
 - Angle 25.4 deg
 - Impact Location 53⁷/₁₆ in. (1,359 mm) US of barriers 8 and 9 joint
- Exit Conditions
 - Speed 56.7 mph (91.2 km/h)
 - Angle -7.2 deg
- Exit Box Criterion Pass
- Vehicle Stability Satisfactory
- Vehicle Stopping Distance 164 ft (50.0 m)
- Vehicle Damage
 - VDSTM I-RFQ-3
 - CDCSM I-RYEN2
 - Maximum Interior Deformation 1 in. (25 mm)

- Maximum Test Article Deflections
 - Permanent Set 39.5 in. (1,003 mm)
 - Dynamic 40.7 in. (1,034 mm)
 - Working Width 51.9 in. (1,318 mm)
- Maximum Angular Displacements
 - Roll 14.95° < 75°
 - Pitch -5.92° < 75°
 - Yaw -35.07°
- Impact Severity (IS) 128.6 kip-ft (174.4 kJ) > 106 kip-ft (144 kJ)

Evaluation Criteria		Transducer			MASH Limit
		EDR-3	EDR-4	DTS	
OIV ft/s (m/s)	Longitudinal	12.11 (3.69)	12.30 (3.75)	12.99 (3.96)	≤ 40 (12.2)
	Lateral	21.05 (6.42)	21.41 (6.53)	23.06 (7.03)	≤ 40 (12.2)
ORA g's	Longitudinal	4.85	5.56	5.66	≤ 20.49
	Lateral	7.68	8.52	7.04	≤ 20.49
THIV – ft/s (m/s)		NA	23.92 (7.29)	25.56 (7.79)	not required
PHD – g's		NA	9.23	8.31	not required
ASI		1.34	1.32	1.42	not required

Figure 141. Summary of Test Results and Sequential Photographs, Test No. RDTCB-2

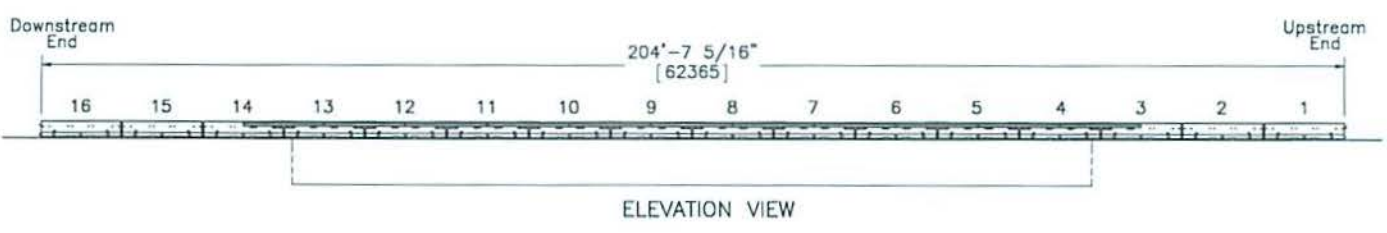
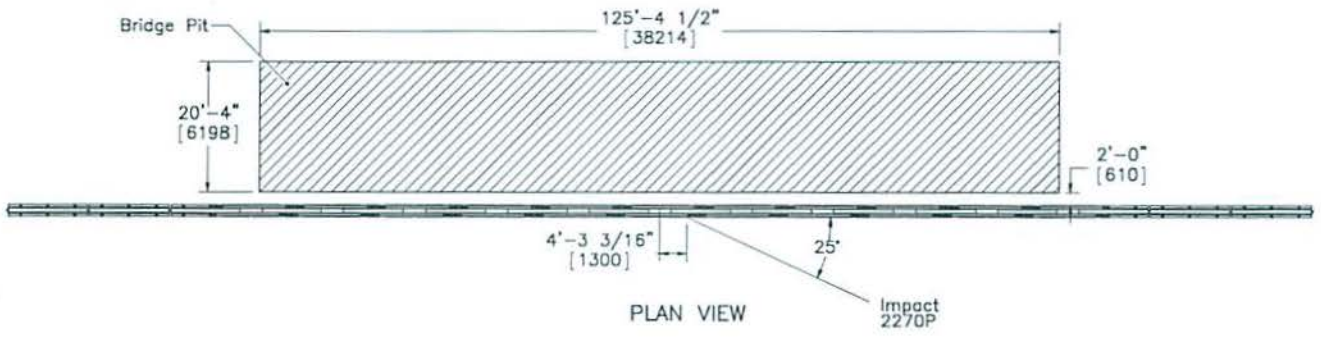

Note: (1) Impact location is 51 3/16" [1300] upstream of joint between barrier nos. 8 and 9.

 Midwest Roadside Safety Facility	Wisconsin DOT Low Deflection Portable Concrete Barrier	SHEET: 1 of 19
	System Layout	DATE: 2/11/2014
DWG. NAME: LDPCB_V2_R7	SCALE: 1:270 UNITS: in [mm]	DRAWN BY: SDB/EJG
		REV. BY: RWS/KAL

Downstream

Upstream

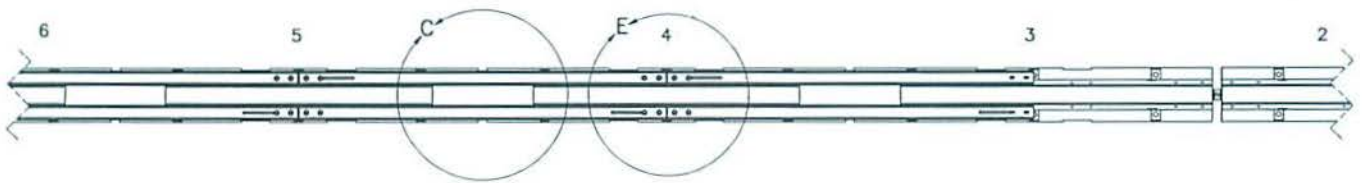

PLAN VIEW

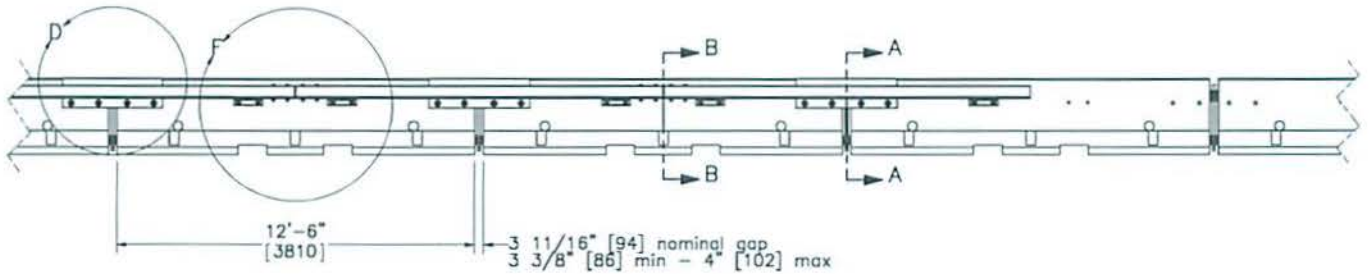

ELEVATION VIEW

Note: (1) Bridge deck omitted.

 Midwest Roadside Safety Facility	Wisconsin DOT Low Deflection Portable Concrete Barrier	SHEET: 2 of 19 DATE: 2/11/2014 DRAWN BY: SDB/LSG
	Concrete Barrier Assembly	DWG. NAME: LDPCB_V2_R7 SCALE: 1:60 UNITS: in./mm REV. BY: RWB/KAL

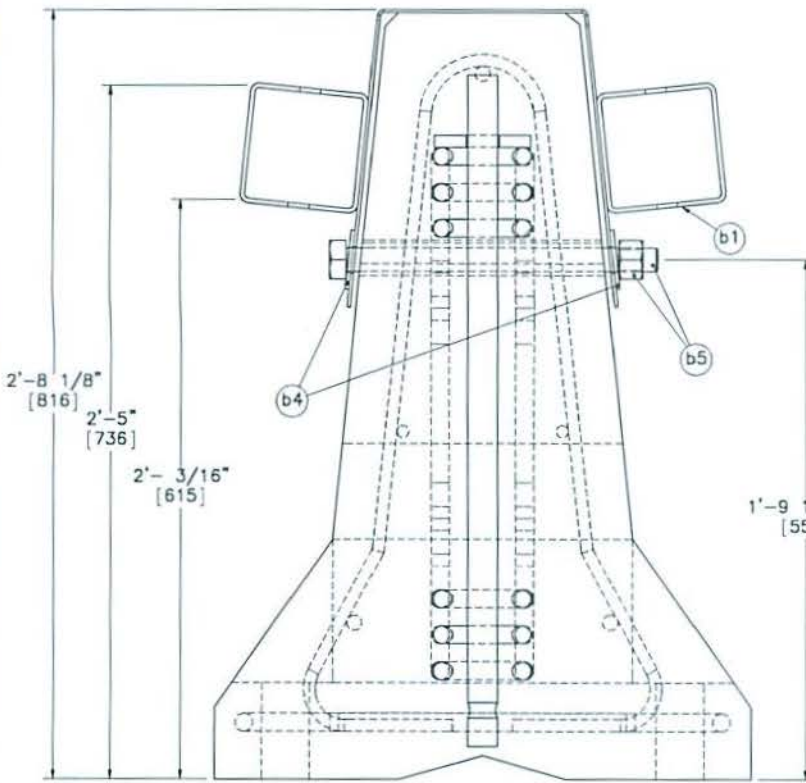

SECTION A-A

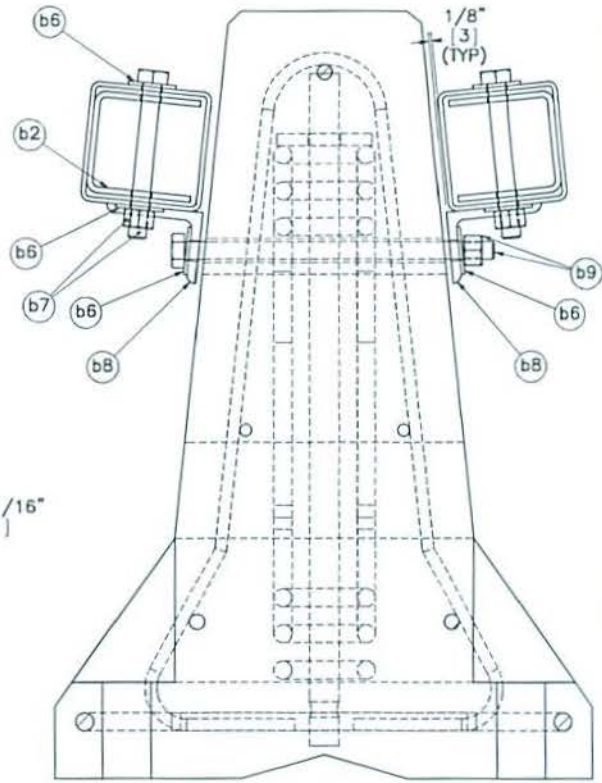

SECTION B-B

- Notes: (1) ASTM A449 or ASTM A193 B7 threaded rod may be used in lieu of bolts (Parts b9 and b5).
 (2) If threaded rod is used in lieu of cup or L-Bracket bolts, limit thread extension beyond nut to 1/4"-1/2" [6-13].

 Midwest Roadside Safety Facility	Wisconsin DOT Low Deflection Portable Concrete Barrier	SHEET: 3 of 13
	Assembly Section View	DATE: 2/11/2014
DWG. NAME: LDPCB_V2_R7	SCALE: 1:8 UNITS: in./mm	DRAWN BY: SDB/ESG
		REV. BY: RWS/KJL

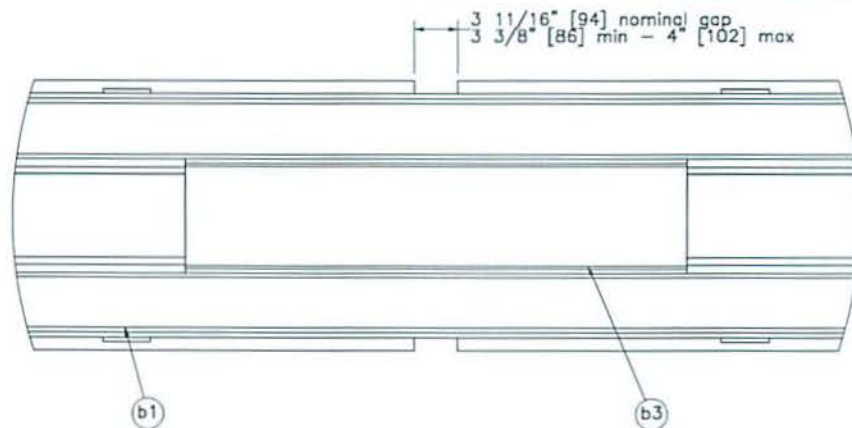

DETAIL C (PLAN VIEW)

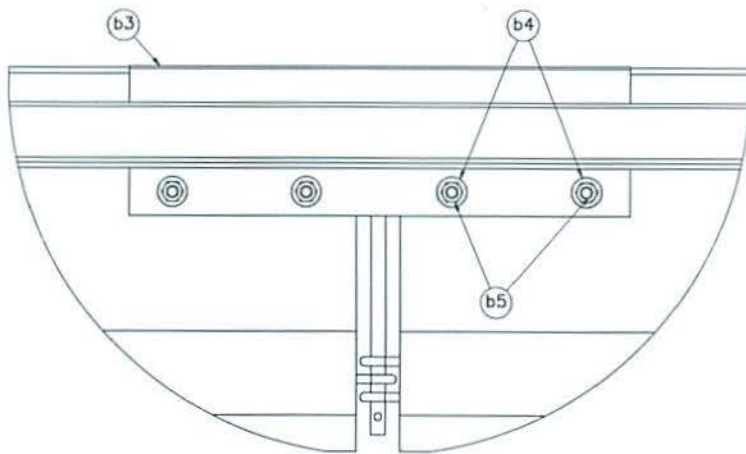

DETAIL D (ELEVATION VIEW)

- Notes: (1) Shown with nominal gap, but variations in gap width will change overlap of cap.
 (2) Cap shall be centered over joint.

	Wisconsin DOT Low Deflection Portable Concrete Barrier	SHEET: 4 of 10
	Mounting Bracket Detail	DATE: 2/11/2014
Midwest Roadside Safety Facility	DWG. NAME: LDPCB_V2_R7	DRAWN BY: SOB/ESC
	SCALE: 1:12 UNITS: in [mm]	REV. BY: RWB/KAL

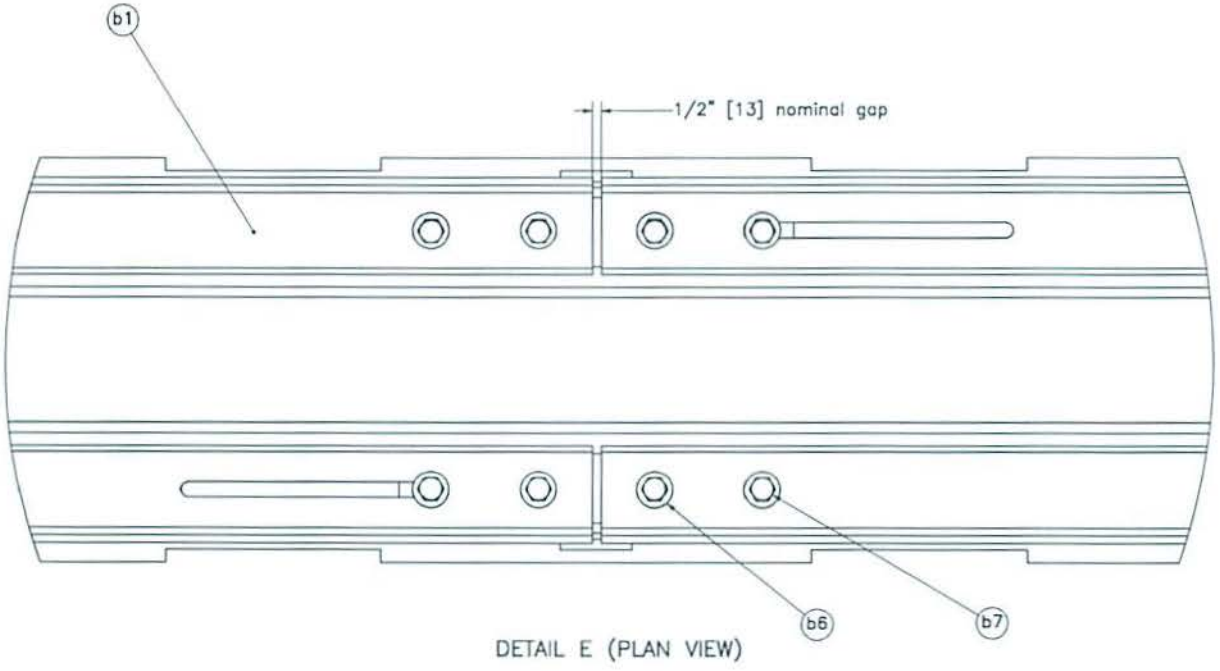

DETAIL E (PLAN VIEW)

	Wisconsin DOT Low Deflection Portable Concrete Barrier		SHEET: 5 of 13
	Splice Connection Detail		DATE: 2/11/2014
Midwest Roadside Safety Facility	DWG. NAME: LDPCB_V2_R7	SCALE: 1:8 UNITS: in.(mm)	DRAWN BY: SOR/ESG REV. BY: RWB/KAL

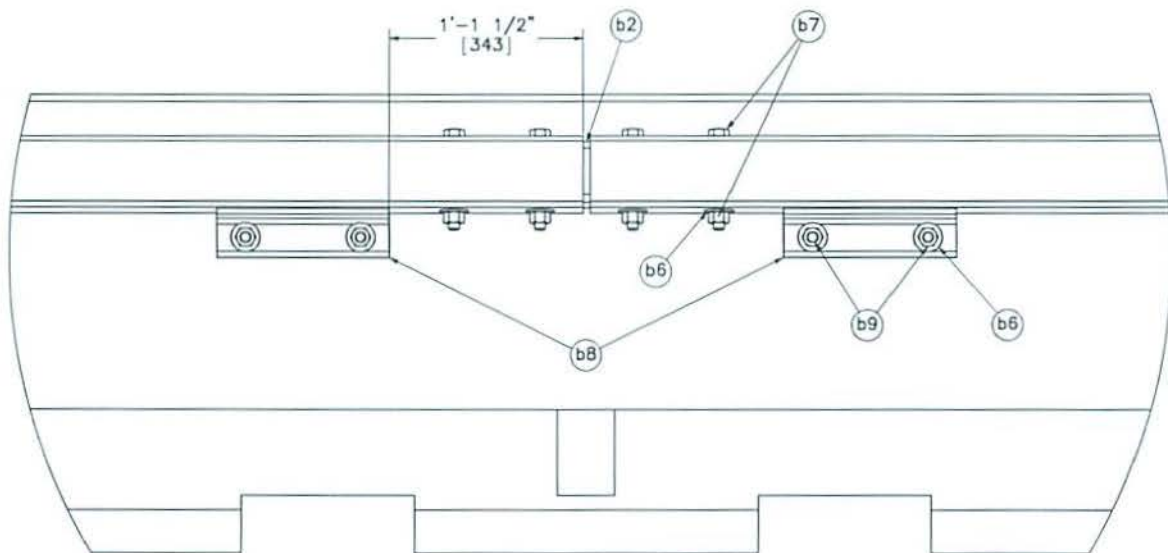

DETAIL F (ELEVATION VIEW)

 Midwest Roadside Safety Facility	Wisconsin DOT Low Deflection Portable Concrete Barrier	SHEET: 6 of 13
	Splice Connection/L-Bracket Detail	DATE: 2/11/2014
DWG. NAME: LDPCB_V2_R7	SCALE: 1:10 UNITS: in./mm	DRAWN BY: SDB/E10
		REV. BY: RWB/KJL

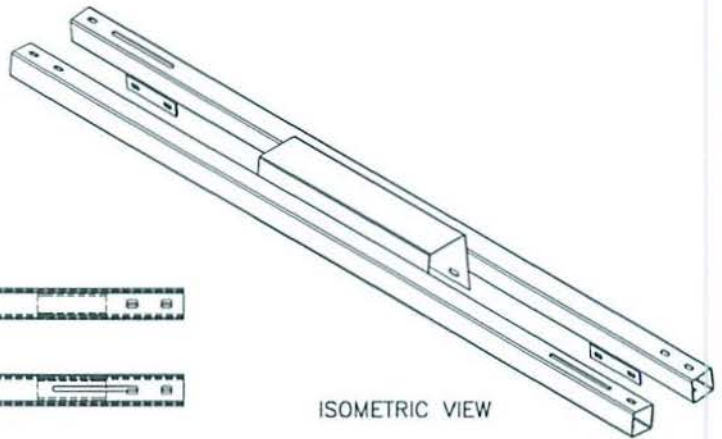

ISOMETRIC VIEW



PLAN VIEW

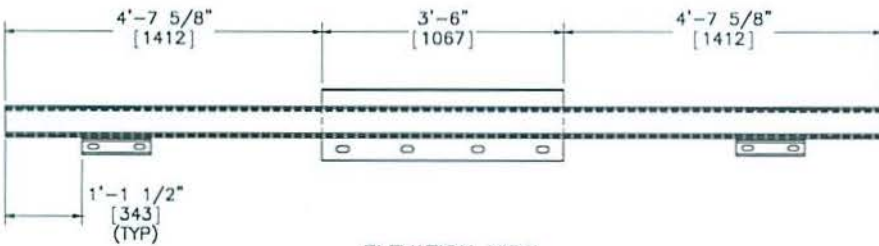

ELEVATION VIEW

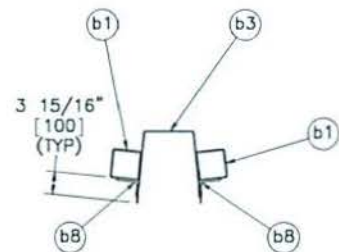

PROFILE VIEW

Note: (1) Parts shall be galvanized after assembly and welding.



Midwest Roadside Safety Facility

Wisconsin DOT Low Deflection Portable Concrete Barrier

Mounting Bracket Assembly

DWG. NAME:
LDPCB_V2_R7

SCALE: 1:25
UNITS: In./mm

SHEET:
7 of 16
DATE:
2/11/2014
DRAWN BY:
SDB/ESG
REV. BY:
RWB/KAL

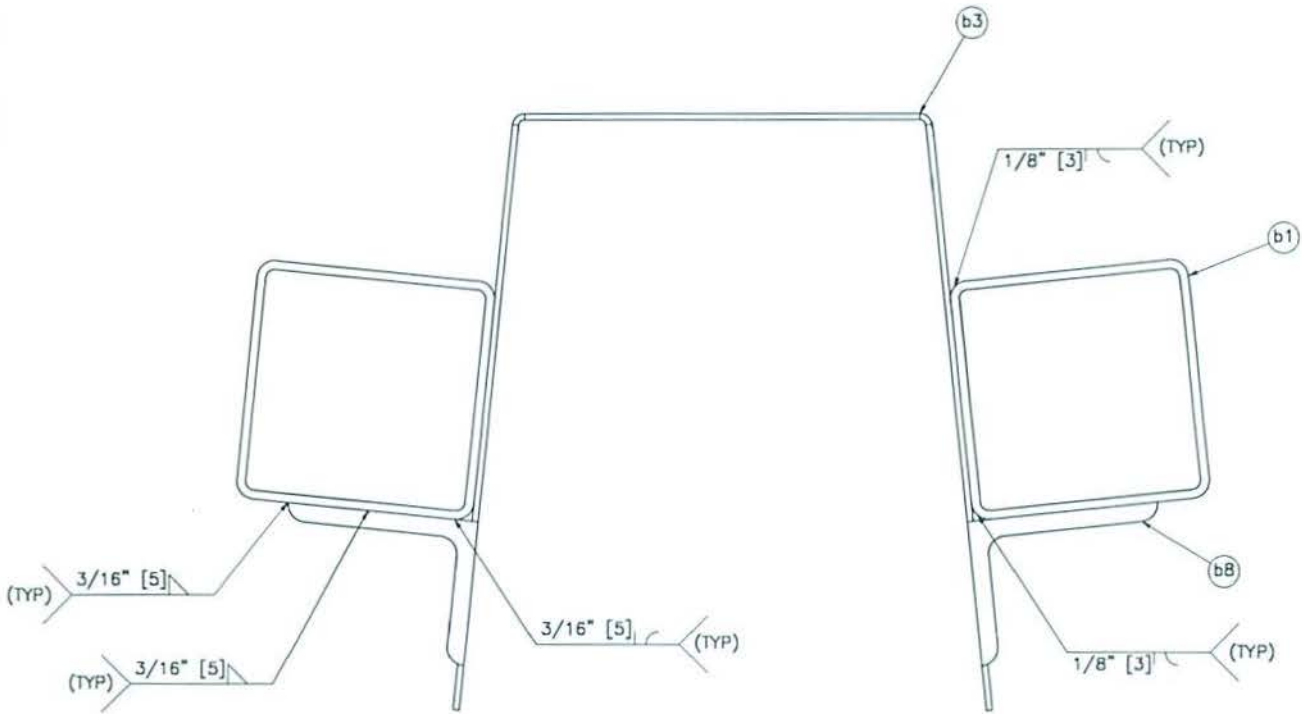

PROFILE VIEW
SCALE 1:3

	Wisconsin DOT Low Deflection Portable Concrete Barrier	SHEET: 8 of 10
	Mounting Bracket Weld Locations	DATE: 2/11/2014
Midwestern Roadside Safety Facility	Dwg. Name: LDPCB_V2_R7	DRAWN BY: SDB/ESG
	SCALE: 1:768 UNITS: in./mm	REV. BY: RWB/WAL

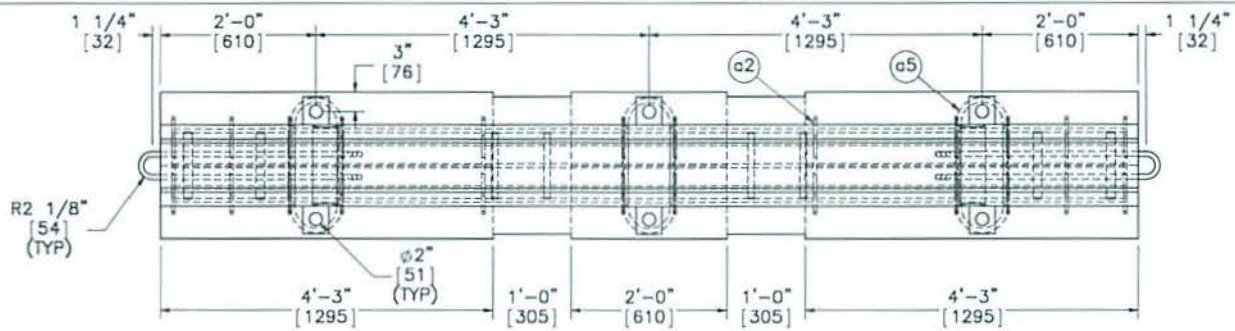

PLAN VIEW

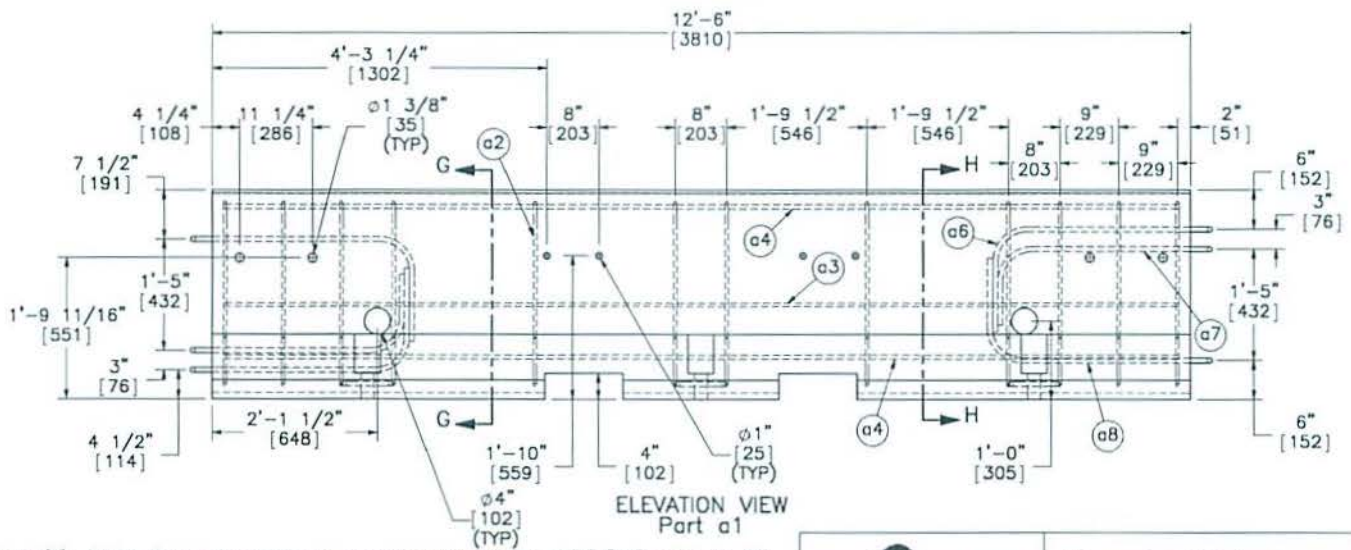

ELEVATION VIEW
Part a1

- Notes: (1) Holes for barrier joint are prefabricated using 1 1/4" [32] schedule 40 PVC with inner diameter of 1.36" [35].
- (2) The nominal hole size of 1 3/8" [35] should be used for actual installations.
- (3) Due to prototype fabrication issues, hole location tolerances were 1/4"-1/2" [6-13] off in vertical and longitudinal direction. Thus, for testing, PVC was removed to increase hole diameter to 1.66" [42] and allow for bolt installation. This would represent a worse case scenario for bolt hole tolerances.



Midwest Roadside
Safety Facility

Wisconsin DOT Low
Deflection Portable
Concrete Barrier

Portable Concrete Barrier
Details

DWG. NAME:
LDPCB_V2_R7

SCALE: 1:22
UNITS: in./mm

SHEET:
9 of 16
DATE:
2/11/2014
DRAWN BY:
SDB/EL33
REV. BY:
RWB/KAL

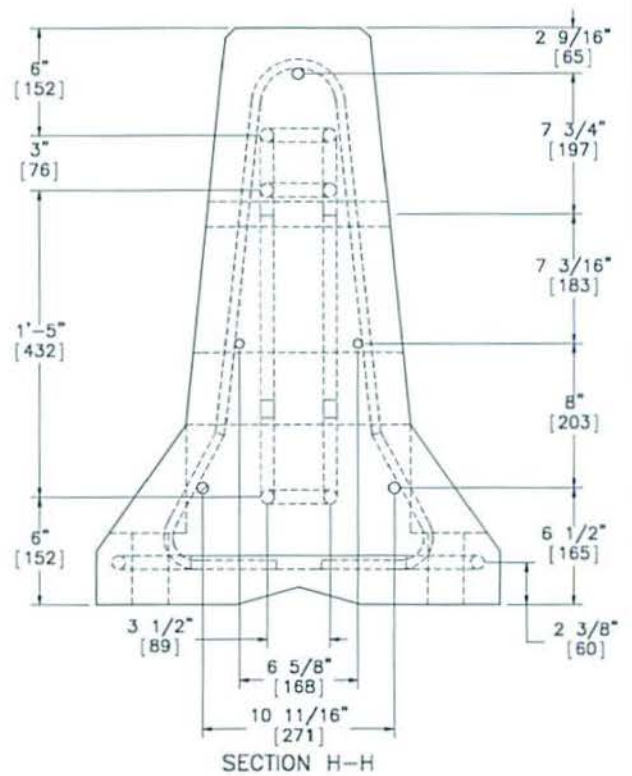
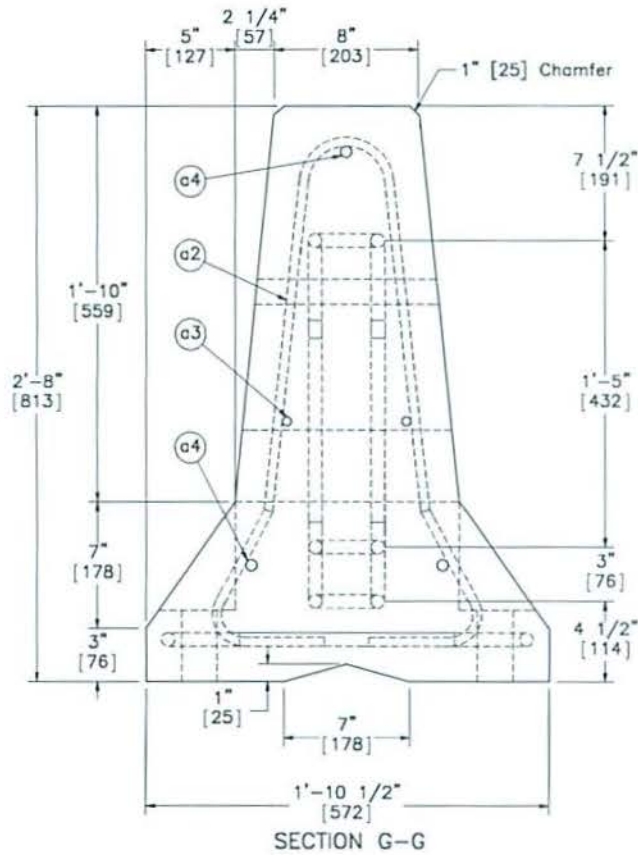

Note: (1) 2" [51] clear cover used for all reinforcement.

	Wisconsin DOT Low Deflection Portable Concrete Barrier	SHEET: 10 of 18
	Portable Concrete Barrier Details	DATE: 2/11/2014
Midwest Roadside Safety Facility	DWG. NAME: LDPCB_V2_R7	DRAWN BY: SDB/ESG
	SCALE: 1:8 UNITS: in./mm	REV. BY: RWB/KAL

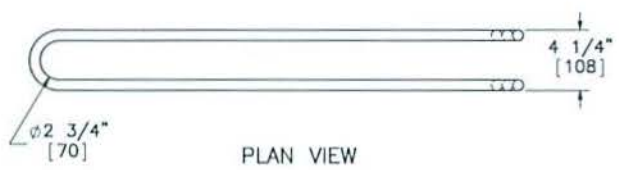

PLAN VIEW

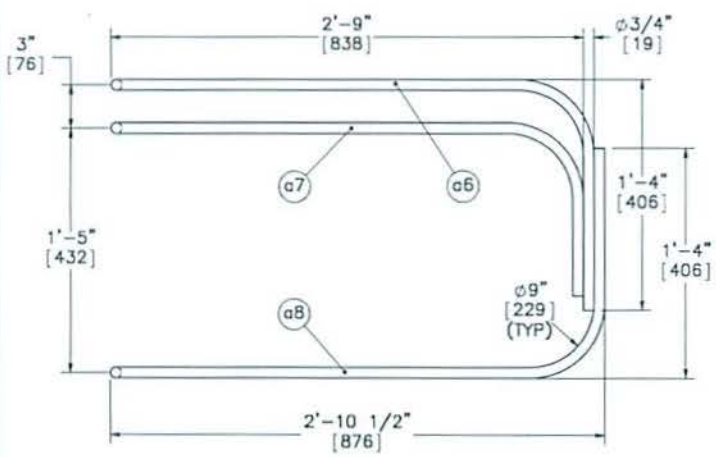

ELEVATION VIEW

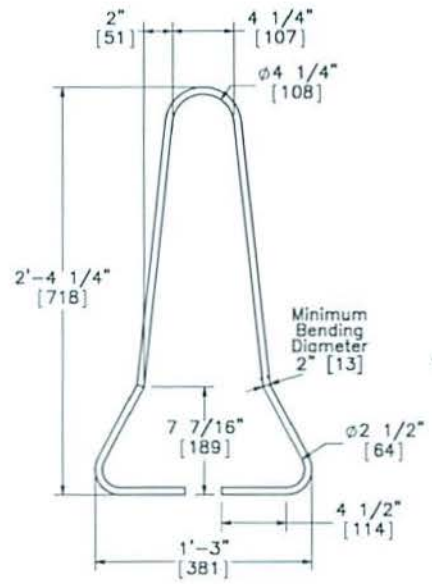

PROFILE VIEW
Part a2

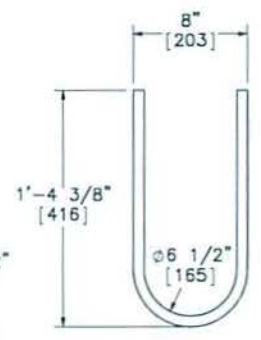

PLAN VIEW
Part a5

	Wisconsin DOT Low Deflection Portable Concrete Barrier	SHEET: 11 of 13
	Portable Concrete Barrier Rebar Details	DATE: 2/11/2014
Midwest Roadside Safety Facility	DWG. NAME: LDPCB_V2_R7	DRAWN BY: SDB/ESC
	SCALE: 1:10 UNITS: in./mm	REV. BY: RWB/KAL



PLAN VIEW



ISOMETRIC VIEW

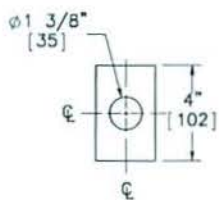

PLAN VIEW

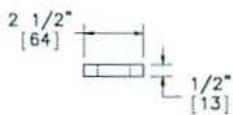

ELEVATION VIEW
PLATE

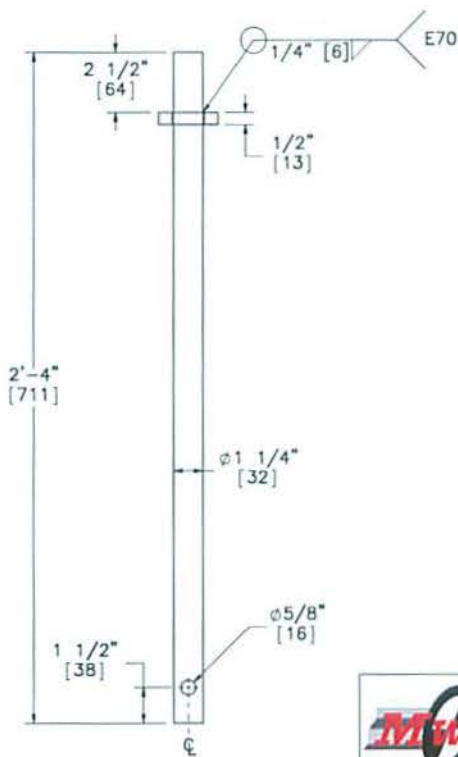

ELEVATION VIEW
Part a9



Midwest Roadside
Safety Facility

Wisconsin DOT Low
Deflection Portable
Concrete Barrier

Connector Pin Details

DWG. NAME:
LDPCB_V2_R7

SCALE: 1:5
UNITS: in./mm

SHEET:
12 of 19

DATE:
2/11/2014

DRAWN BY:
SDB/ESG

REV. BY:
RWB/KAL

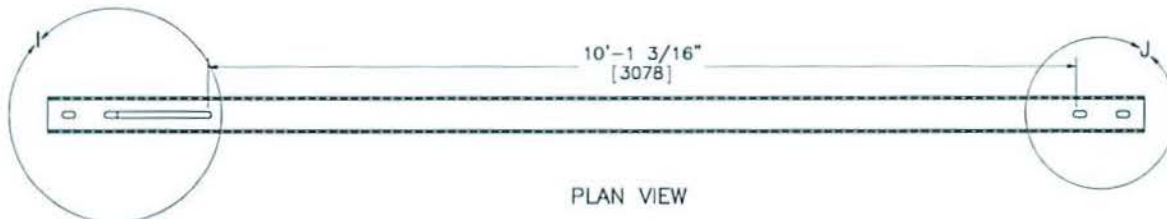

PLAN VIEW

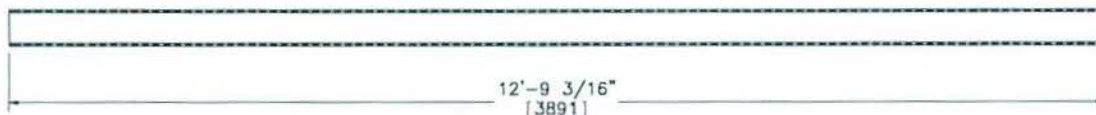

ELEVATION VIEW

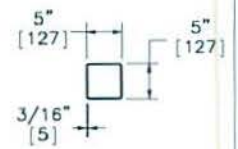

PROFILE VIEW

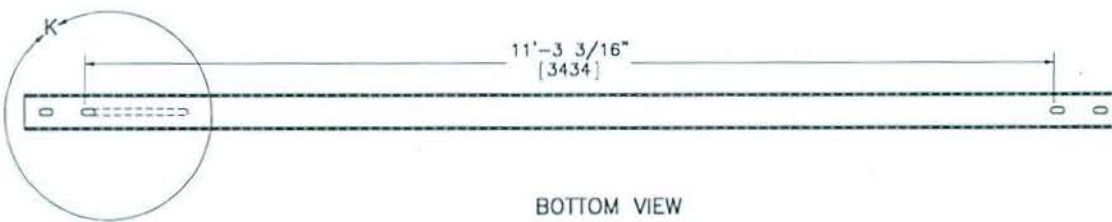

BOTTOM VIEW

Part b1

	Wisconsin DOT Low Deflection Portable Concrete Barrier	SHEET: 13 of 19
	Splice Main Tube	DATE: 2/11/2014
Midwest Roadside Safety Facility	DRAWN BY: SOB/ESG	REV. BY: RWB/KAL
DWG. NAME: LDPCB_V2_R7	SCALE: 1:20 UNITS: in.(mm)	

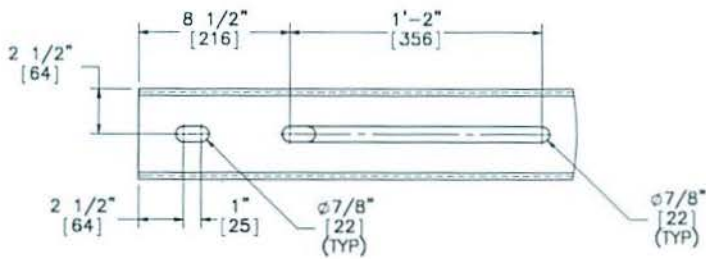

DETAIL I (PLAN VIEW)

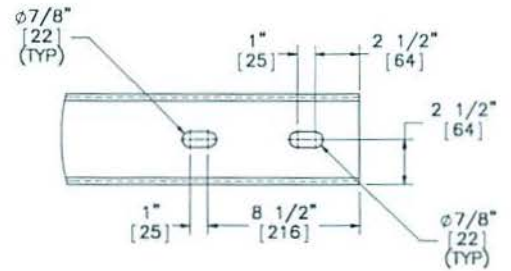

DETAIL J (PLAN VIEW)

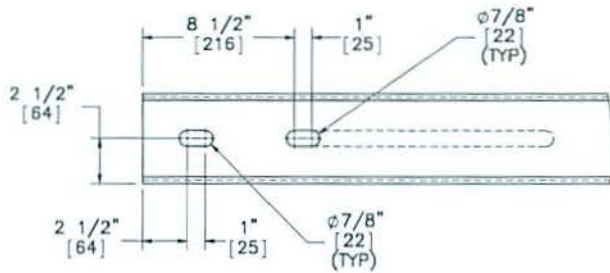

DETAIL K (BOTTOM VIEW)

	Wisconsin DOT Low Deflection Portable Concrete Barrier		SHEET: 14 of 18
	Splice Slot Detail		DATE: 2/11/2014
Midwest Roadside Safety Facility	DWG. NAME: LDPCB_V2_R7	SCALE: 1:8 UNITS: in./mm	DRAWN BY: SOE/ESQ REV. BY: RWB/KAL

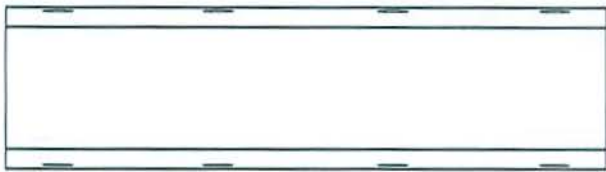

PLAN VIEW

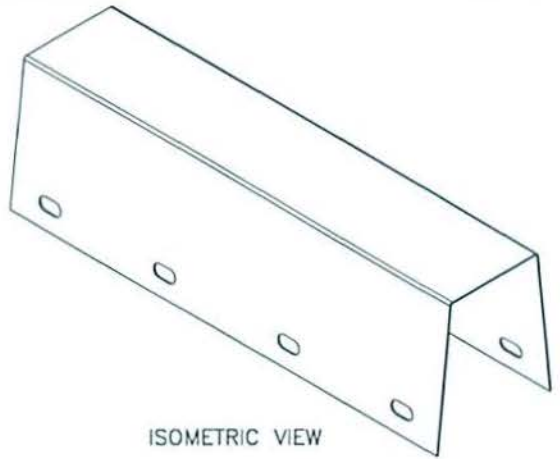

ISOMETRIC VIEW

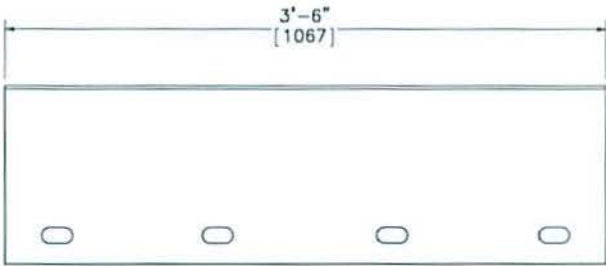

ELEVATION VIEW

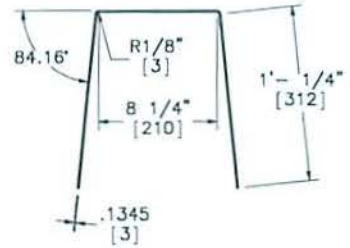

PROFILE VIEW

Part b3

	Wisconsin DOT Low Deflection Portable Concrete Barrier	SHEET: 15 of 19
	Mounting Bracket (Bent)	DATE: 2/11/2014
Midwest Roadside Safety Facility	DWG. NAME: LDPCB_V2_R7	DRAWN BY: SDB/ESG
	SCALE: 1:10 UNITS: in.[mm]	REV. BY: RWB/KAL

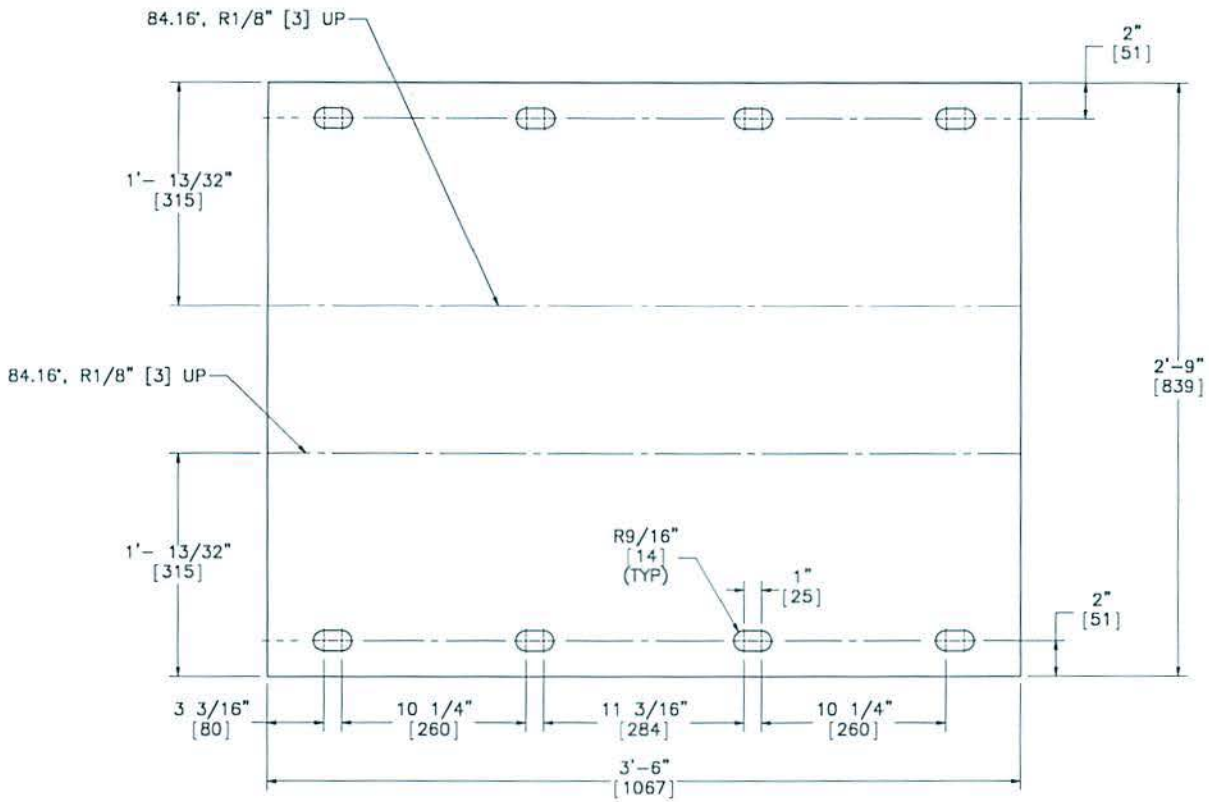

Part b3 (Unbent)

	Wisconsin DOT Low Deflection Portable Concrete Barrier		SHEET: 16 of 19
	Midwest Roadside Safety Facility		DATE: 2/11/2014
Mounting Bracket (Unbent)		DWG. NAME: LDPB_V2_R7	DRAWN BY: SDB/ESG
		SCALE: 1:8 UNITS: in./mm	REV. BY: RWS/KAL

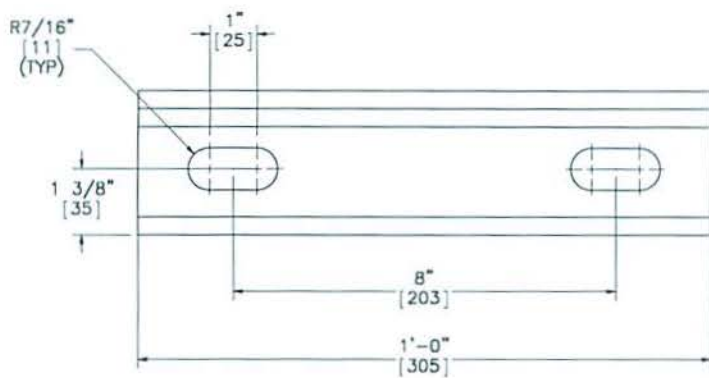

ELEVATION VIEW

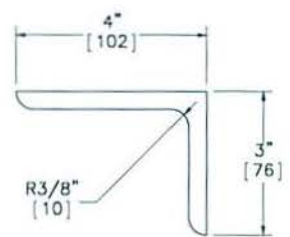

PROFILE VIEW

Part b8

	Wisconsin DOT Low Deflection Portable Concrete Barrier		SHEET: 17 of 18
	L-Bracket		DATE: 2/11/2014
Midwest Roadside Safety Facility	DWG. NAME: LDPCB_V2_R7	SCALE 1:3 UNITS: in [mm]	DRAWN BY: SOB/ESG
			REV. BY: RWB/KAL

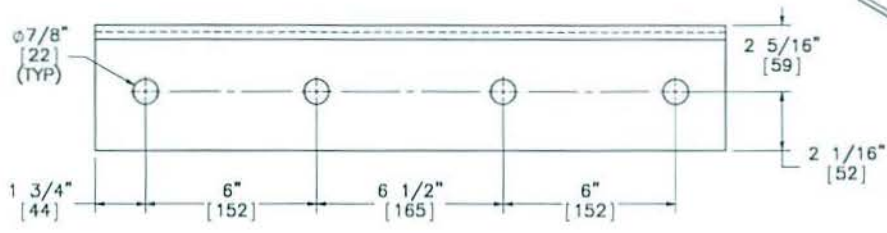

PLAN VIEW

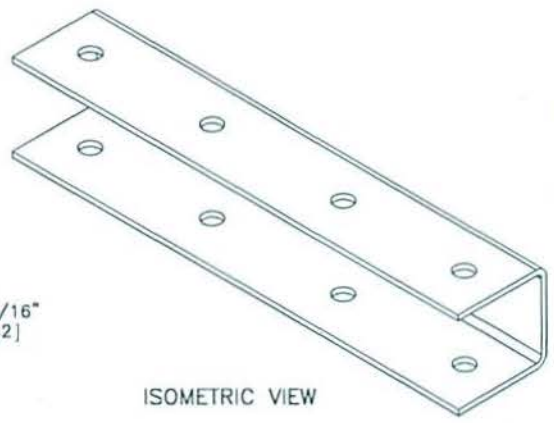

ISOMETRIC VIEW

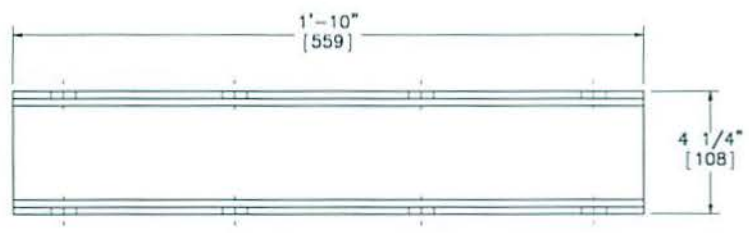

ELEVATION VIEW

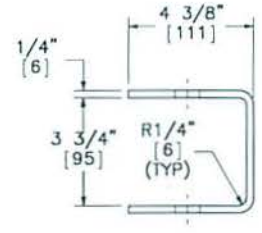

PROFILE VIEW

Part b2

 Midwest Roadside Safety Facility	Wisconsin DOT Low Deflection Portable Concrete Barrier	SHEET: 18 of 19
	Splice Insert	DATE: 2/11/2014
DWG. NAME: LDPCB_V2_R7	SCALE: 1:5 UNITS: in [mm]	DRAWN BY: SDB/ESG
		REV. BY: RWS/KAL

Item No.	QTY.	Description	Material Specifications	Hardware
a1	16	Portable Concrete Barrier	min f'c=5000 psi [34.5 MPa]	SWC09
a2	192	1/2" [13] Dia., 72" [1829] Long Form Bar	ASTM A615 Grade 60	SWC09
a3	32	1/2" [13] Dia., 146" [3708] Long Longitudinal Bar	ASTM A615 Grade 60	SWC09
a4	48	5/8" [16] Dia., 146" [3708] Long Longitudinal Bar	ASTM A615 Grade 60	SWC09
a5	96	3/4" [19] Dia., 36" [914] Long Anchor Loop Bar	ASTM A615 Grade 60	SWC09
a6	32	3/4" [19] Dia., 101" [2565] Long Connection Loop Bar	ASTM A709 Grade 70 or A706 Grade 60	SWC09
a7	32	3/4" [19] Dia., 91" [2311] Long Connection Loop Bar	ASTM A709 Grade 70 or A706 Grade 60	SWC09
a8	32	3/4" [19] Dia., 102" [2591] Long Connection Loop Bar	ASTM A709 Grade 70 or A706 Grade 60	SWC09
a9	15	1 1/4" [32] Dia., 28" [711] Long Connector Pin	ASTM A36 Galvanized	FMW02
b1	22	5"x5"x3/16" [127x127x5], 12'-9 3/16" [3891] Long Splice Main Tube	ASTM A500 Grade B Galvanized after Welding	-
b2	20	4 1/2"x4 1/2"x1/4" [114x114x6], 22" [559] Long Splice Insert	ASTM 572 Grade 50 Galvanized	-
b3	11	42"x33" [1067x838] 10 Gage Mounting Bracket Plate	ASTM A1011 Grade 50 Galvanized after Welding	-
b4	88	1" [25] Dia. Washer	ASTM F844 Galvanized	-
b5	44	1" [25] Dia. UNC, 12 3/4" [324] Long Heavy Hex Bolt and Nut	Bolt ASTM A325/A449 Type 1 Galvanized, Nut ASTM A563 Galvanized	-
b6	248	3/4" [19] Dia. Washer	ASTM F844 Galvanized	-
b7	80	3/4" [19] Dia. UNC, 6 1/2" [165] Long, 2" [51] Threaded Hex Bolt and Nut	Bolt ASTM A325/A449/SAE Grade 5 Galvanized, Nut ASTM A563DH Grade 5 Galvanized	-
b8	44	4"x3"x3/8" [102x76x10], 12" [305] Long L-Bracket	ASTM A529 Grade 50 Galvanized	-
b9	44	3/4" [19] Dia. UNC, 13" [330] Long, 2" [51] Threaded Hex Bolt and Nut	Bolt ASTM A325/A449/SAE Grade 5 Galvanized, Nut ASTM A563DH Grade 5 Galvanized	-



Midwest Roadside
Safety Facility

Wisconsin DOT Low
Deflection Portable
Concrete Barrier

Bill of Materials

DWG. NAME:
LDPCB_V2_R7

SCALE: NONE
UNITS: in (mm)

SHEET:
19 of 19
DATE:
2/11/2014
DRAWN BY:
SDB/LSG
REV. BY:
RWB/KAL



PLAN VIEW

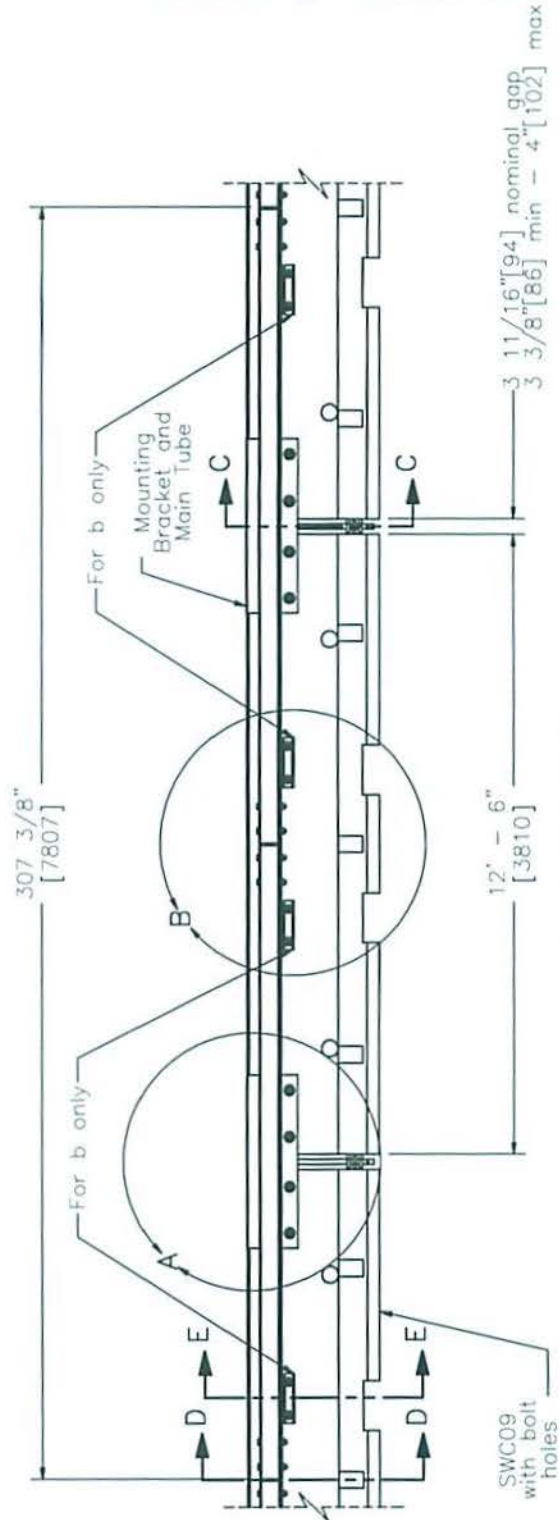

ELEVATION VIEW

RETROFIT, LOW-DEFLECTION, PORTABLE CONCRETE BARRIER



SWC20a-b

SHEET NO.

DATE:

1 of 10

3/19/2015

INTENDED USE

Retrofit, Low-Deflection, Portable Concrete Barrier is a non-proprietary system and is to be used in situations where limited system deflection is required. The Retrofit, Low-Deflection, Portable Concrete Barrier should be used in locations where a maximum dynamic deflection of 43.0" [1,092] or less is acceptable and where a working width of 55.1" [1,400] is provided. The Retrofit, Low-Deflection, Portable Concrete Barrier with L-Brackets should be used in locations where a maximum dynamic deflection of 40.7" [1,034] or less is acceptable and where a working width of 51.9" [1,318] is provided. The system should be placed with a minimum distance of 24" [610] between the back face of the concrete barrier and the edge of the bridge deck or drop off. Retrofit, Low-Deflection, Portable Concrete Barrier may be used on a concrete or asphalt surface. The Retrofit, Low-Deflection, Portable Concrete Barrier system is intended for use with the Portable F-shape Concrete Barrier Element (SWC09) and the Portable Concrete Barrier Connector Pins with or without the retainer bolt (FMW02 or FMW03). The Portable F-shape Concrete Barrier Elements (SWC09) are to be placed in a straight line or a large radius curve where the existing design tolerances can accommodate the small angles between adjacent Portable F-shape Concrete Barrier Elements (SWC09). The Retrofit, Low-Deflection, Portable Concrete Barrier has been crash tested under Test Level 3 (TL-3) conditions of the Manual for Assessing Safety Hardware (MASH) and deemed acceptable according to the MASH safety performance criteria.

COMPONENTS

Unit Length = 307 3/8" [7807]

DESIGNATOR	COMPONENT	NUMBER	SYSTEM
FBX20a	6 1/2" [165] Hex Bolt and Nut	16	a-b
FBX20b	13" [330] Hex Bolt and Nut	8	b
or FRS20b	14 1/4" [362] Threaded Straight Anchor Stud and Nuts	8	b
FBX24b	12 3/4" [324] Hex Bolt and Nut	8	a-b
or FRS24b	14" [356] Threaded Straight Anchor Stud and Nuts	8	a-b
FMW02	Connector Pin	2	a-b
or FMW03	Connector Pin with Retaining Bolt	2	a-b
FWC20a	Plain Round Washer	48	a-b
FWC24a	Plain Round Washer	16	a-b
SWC09	Portable Concrete Barrier with Bolt Holes	2	a-b
---	10-Gauge Mounting Bracket	2	a-b
---	Main Tube	2	a-b
---	Splice Tube Insert	2	a-b
---	L-Bracket	8	b

ELIGIBILITY

FHWA eligibility will be pursued.

REFERENCES

Bielenberg, R.W., Quinn, T.E., Faller, R.K., Sicking, D.L., and Reid, J.D., *Development of a Retrofit, Low-Deflection, Temporary Concrete Barrier System*, Final Report to Wisconsin Department of Transportation, Transportation Research Report No. TRP-03-295-14, Project No. TPF-5(193) Suppl. #15, Project Code RPPF-WISC-4, Midwest Roadside Safety Facility, University of Nebraska-Lincoln, March 31, 2014.

CONTACT INFORMATION

Midwest Roadside Safety Facility
Nebraska Transportation Center
University of Nebraska-Lincoln
130 Whittier Research Center
2200 Vine Street



RETROFIT, LOW-DEFLECTION, PORTABLE CONCRETE BARRIER



SWC20a-b

SHEET NO.

DATE:

2 of 10

3/19/2015

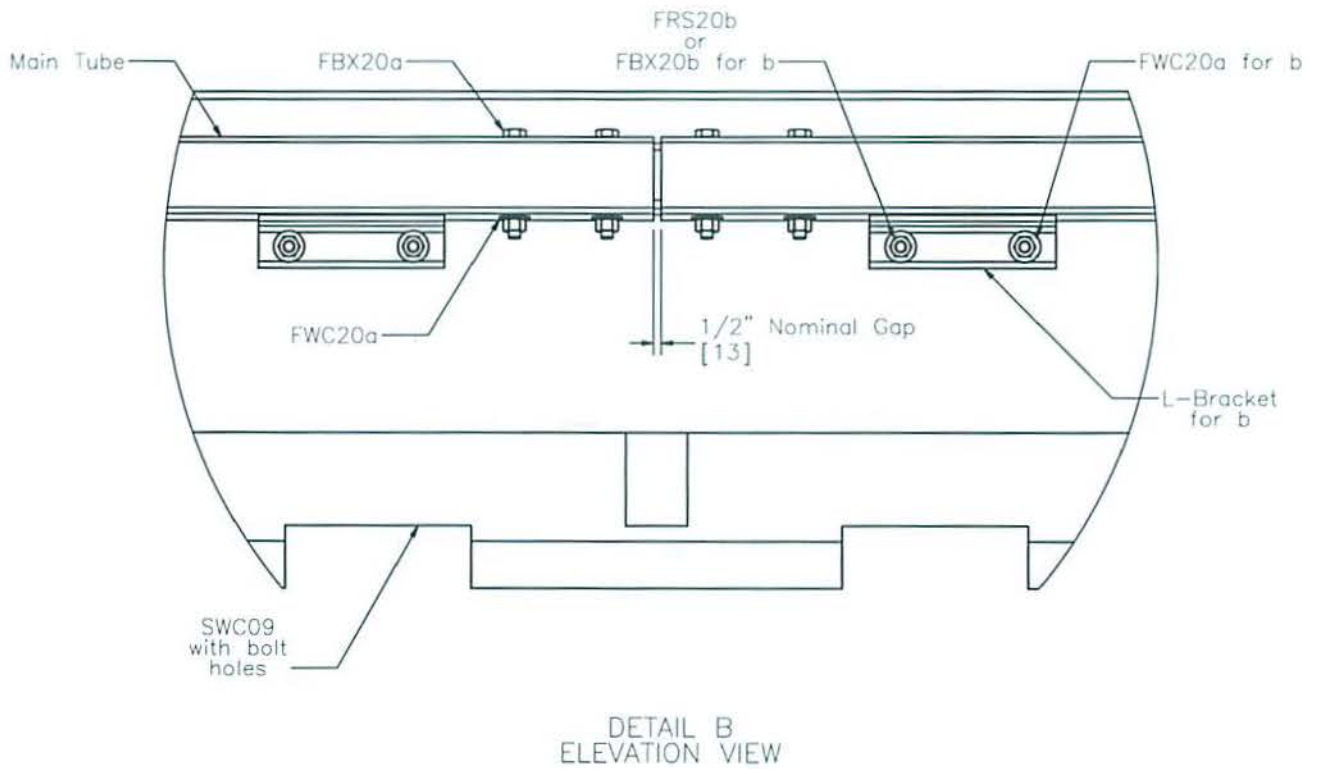
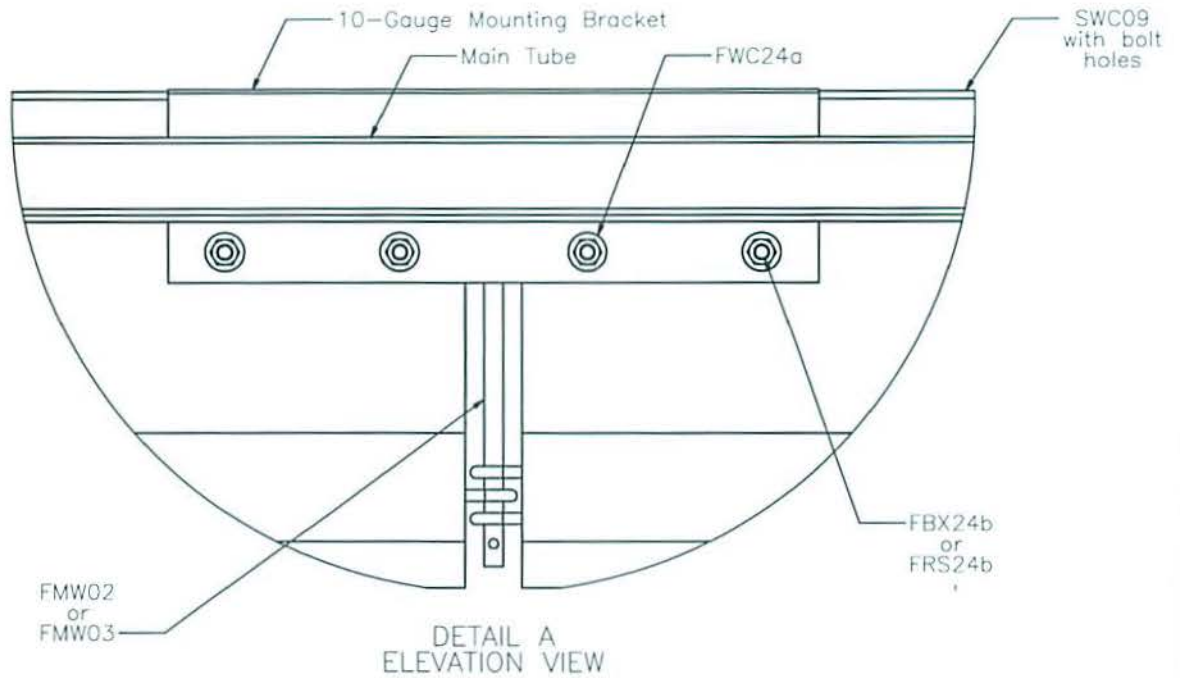

RETROFIT, LOW-DEFLECTION, PORTABLE CONCRETE BARRIER



SWC20a-b

SHEET NO.

DATE:

3 of 10

3/19/2015

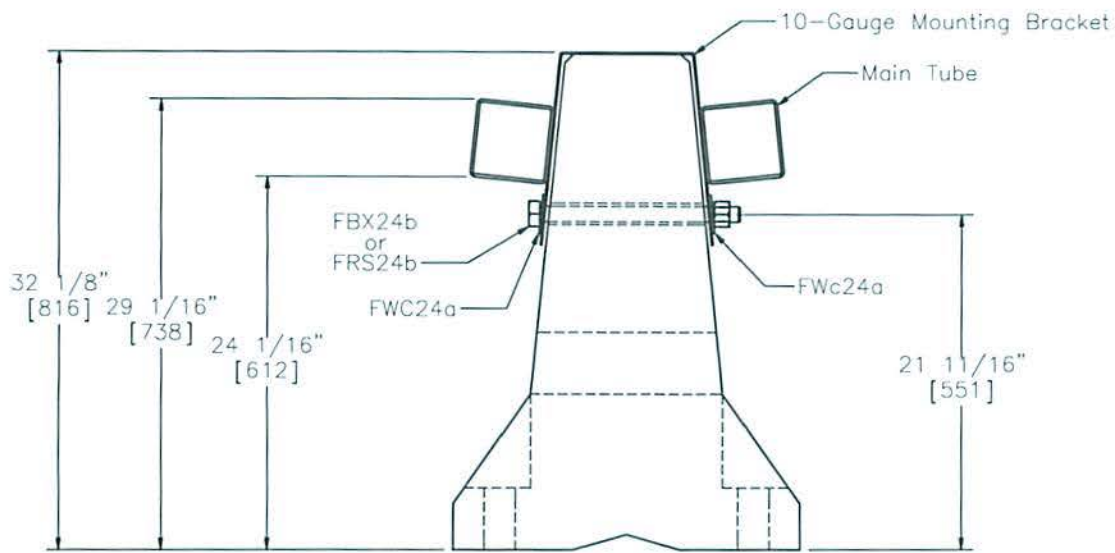

SECTION C-C

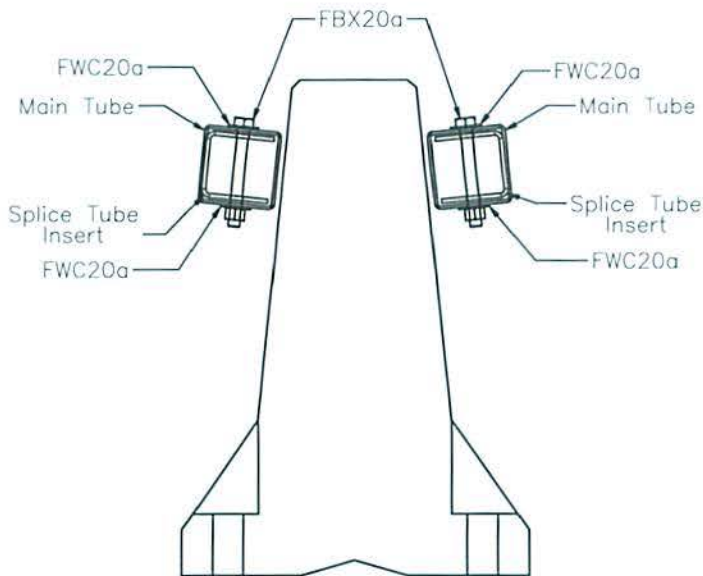

SECTION D-D

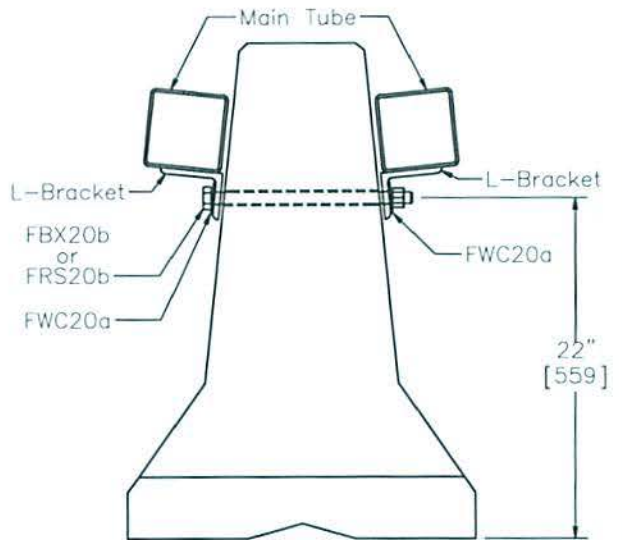

SECTION E-E
for b

RETROFIT, LOW-DEFLECTION, PORTABLE CONCRETE BARRIER



SWC20a-b

SHEET NO.

DATE:

4 of 10

3/19/2015

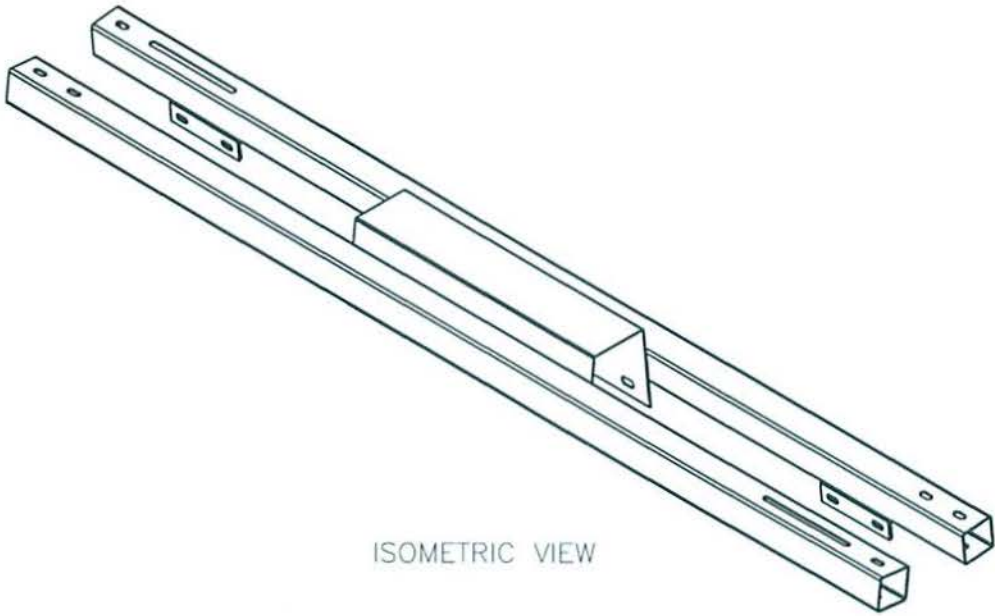

ISOMETRIC VIEW

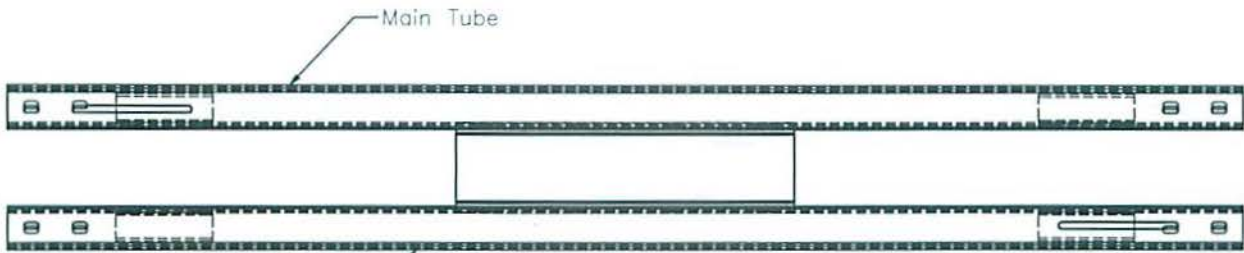

Main Tube
Main Tube
PLAN VIEW

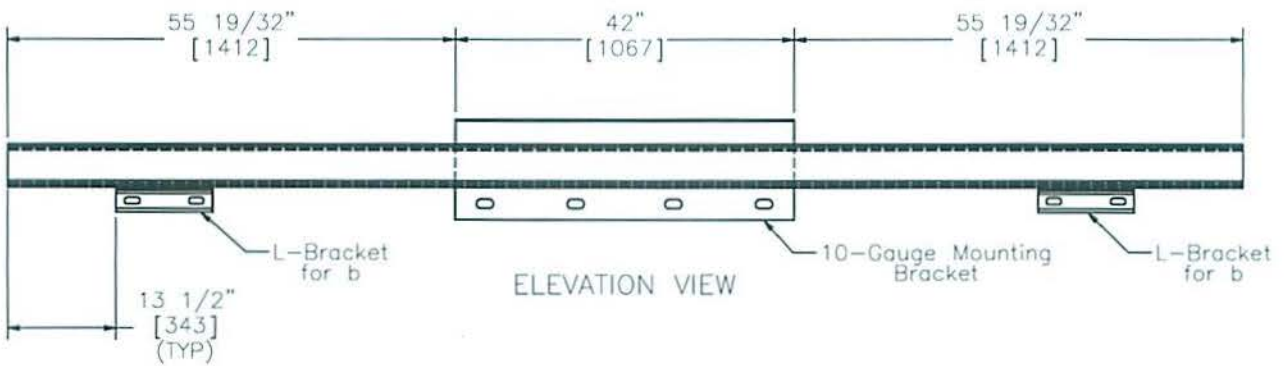

RETROFIT, LOW-DEFLECTION, PORTABLE CONCRETE BARRIER



SWC20a-b

SHEET NO.

DATE:

5 of 10

3/19/2015

SPECIFICATIONS

The Main Tube shall be manufactured using ASTM A500 Grade B steel. The Splice Tube Insert shall be manufactured using ASTM A572 Grade 50 steel or equivalent, and the 10-Gauge Mounting Bracket shall be manufactured using ASTM A1011 Grade 50 steel.

The L-Bracket should be a pre-manufactured piece made from ASTM A529 Grade 50 steel and meeting the dimension specifications herein.

The Main Tube, Mounting Bracket, L-Bracket assembly, and the Splice Tube Insert should be zinc-coated according to AASHTO M111 (ASTM A123) except when corrosion resistant steel is requested.

Dimension tolerances not shown or implied are intended to be those consistent with the proper functioning of the part, including its appearance and accepted manufacturing practices.

RETROFIT, LOW-DEFLECTION, PORTABLE CONCRETE BARRIER



SWC20a-b

SHEET NO.

DATE:

6 of 10

3/19/2015

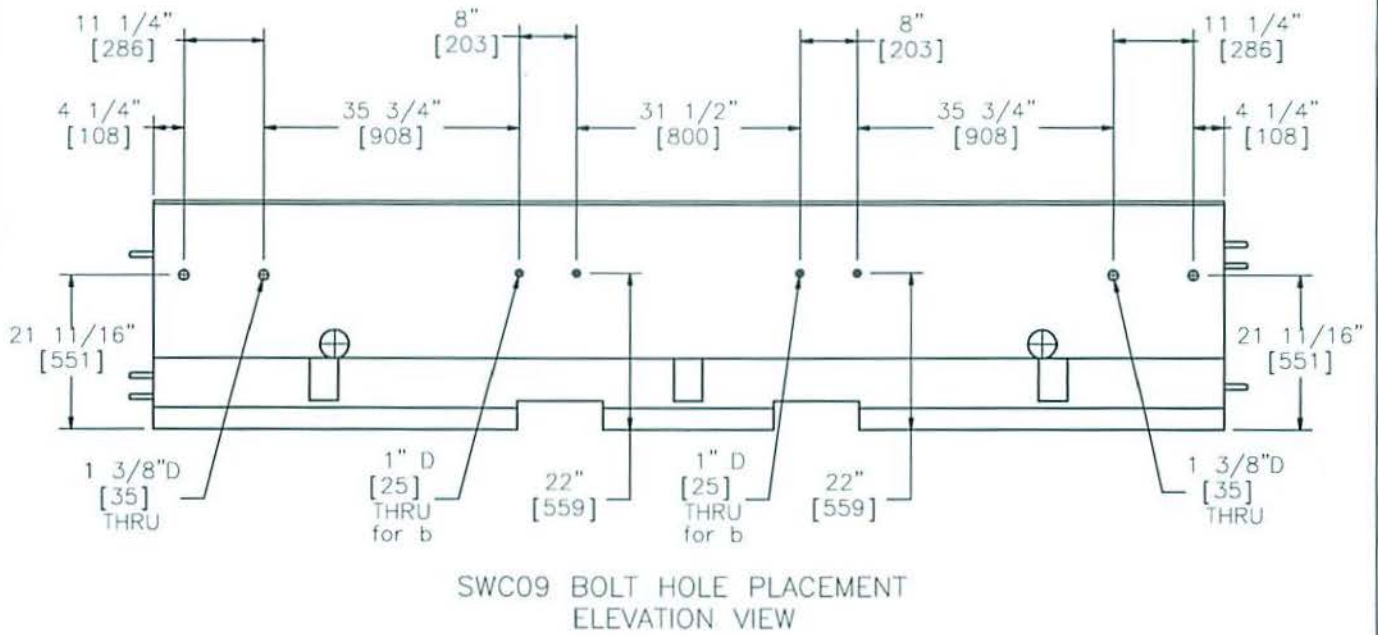
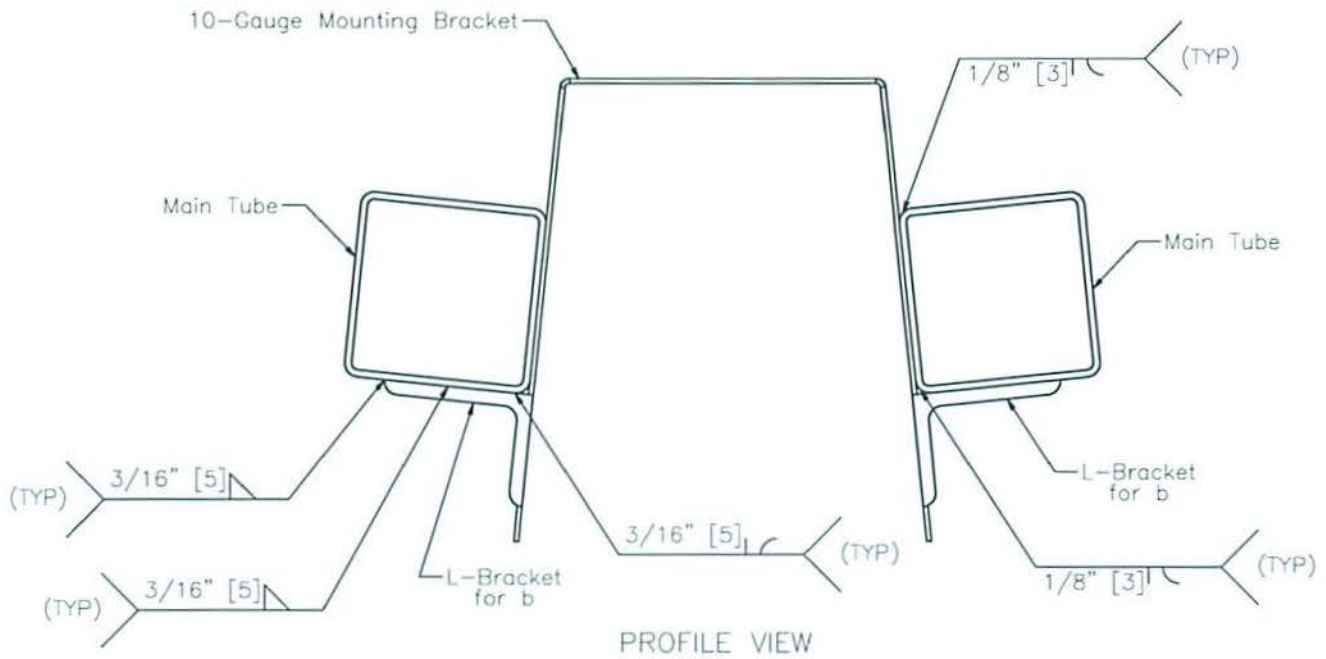

RETROFIT, LOW-DEFLECTION, PORTABLE CONCRETE BARRIER



SWC20a-b

SHEET NO.

DATE:

7 of 10

3/19/2015

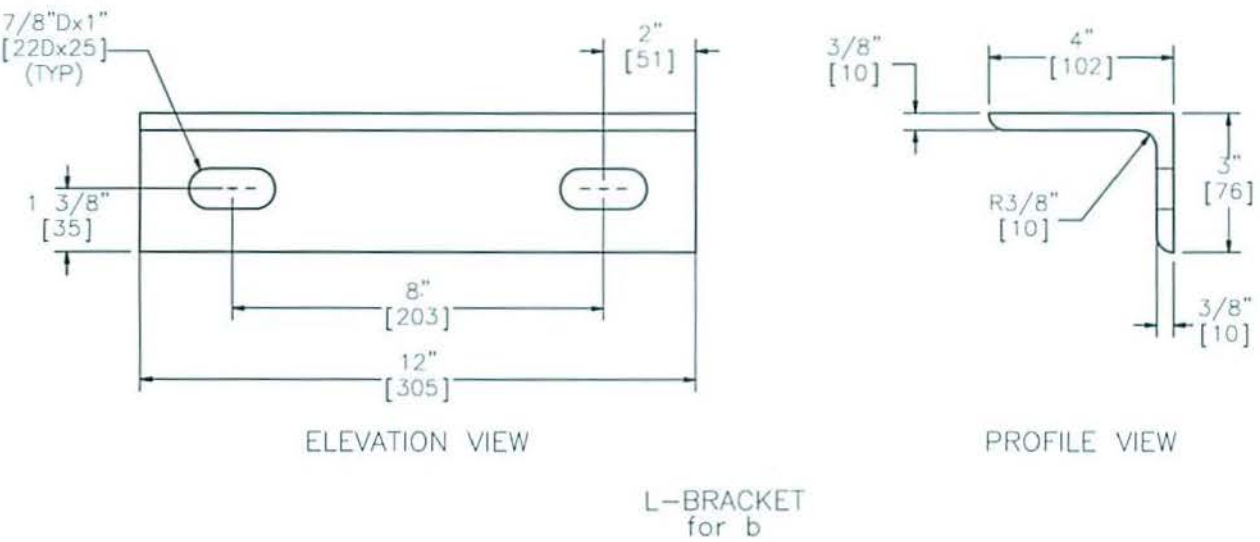
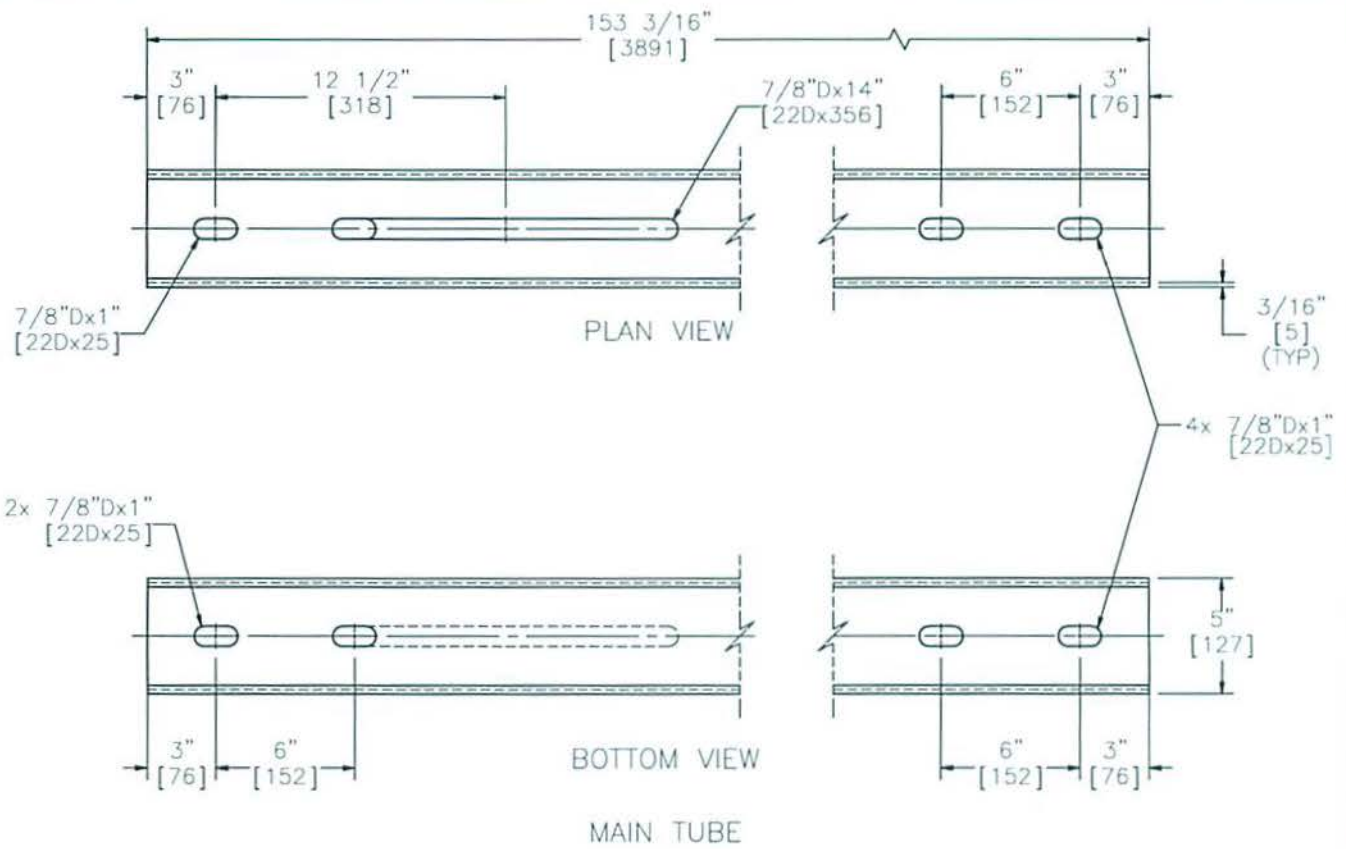

RETROFIT, LOW-DEFLECTION, PORTABLE CONCRETE BARRIER



SWC20a-b

SHEET NO.	DATE:
8 of 10	3/19/2015



PLAN VIEW

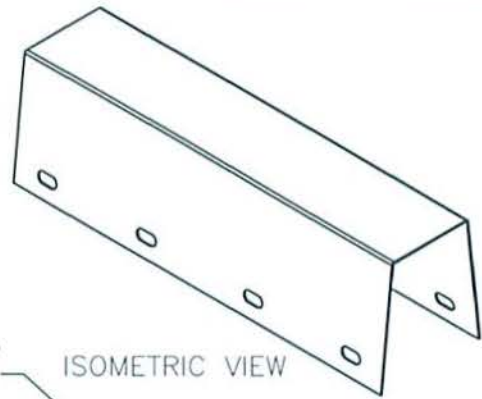

ISOMETRIC VIEW

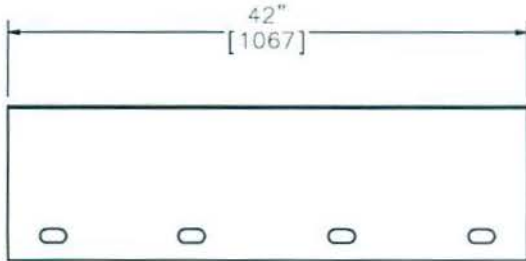

ELEVATION VIEW

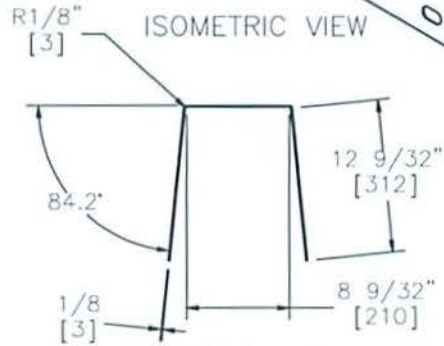

PROFILE VIEW

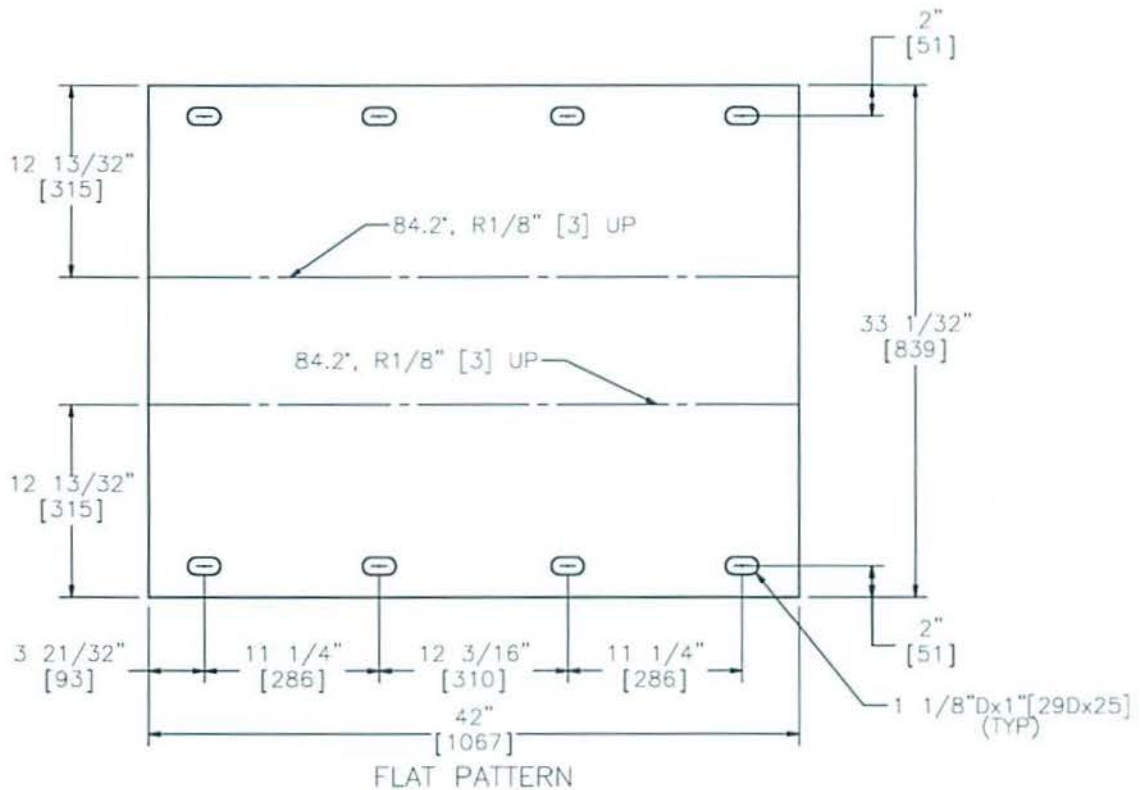

FLAT PATTERN

10-GAUGE MOUNTING BRACKET PLATE

RETROFIT, LOW-DEFLECTION, PORTABLE CONCRETE BARRIER



SWC20a-b

SHEET NO.

DATE:

9 of 10

3/19/2015

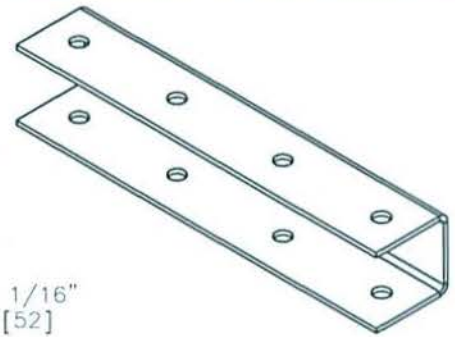
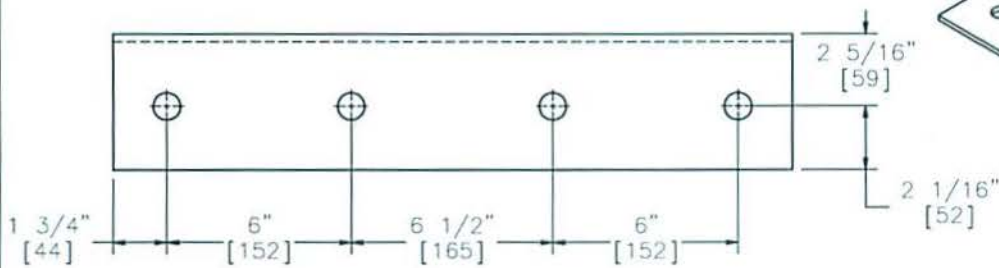

ISOMETRIC VIEW

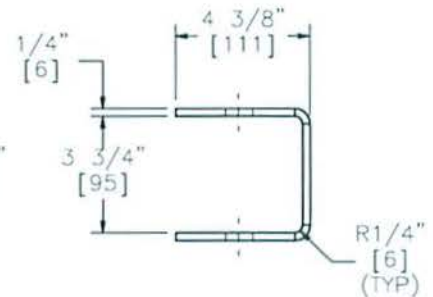
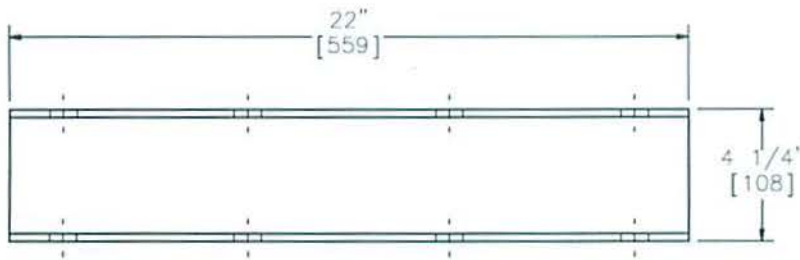

ELEVATION VIEW

PROFILE VIEW

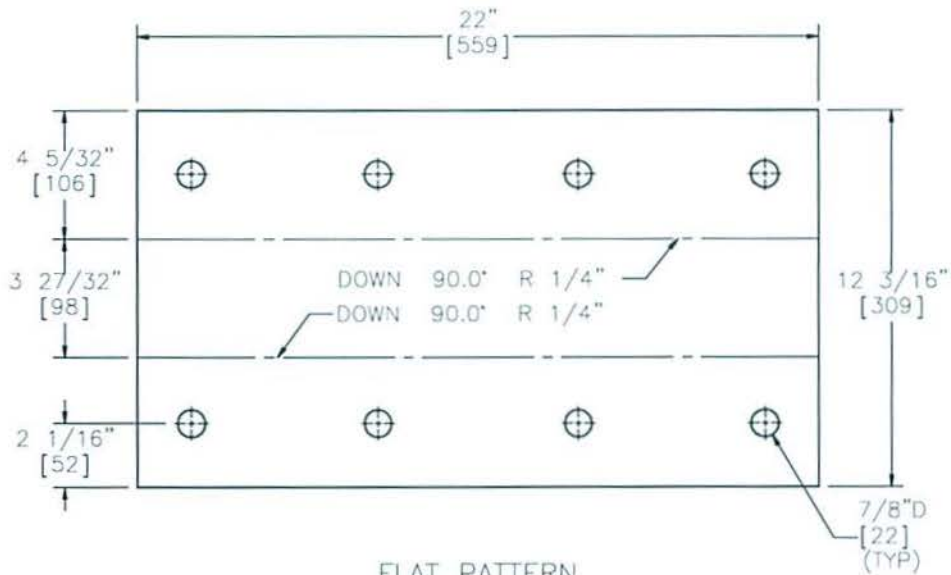

FLAT PATTERN
 SPLICE TUBE INSERT

RETROFIT, LOW-DEFLECTION, PORTABLE CONCRETE BARRIER



SWC20a-b

SHEET NO.	DATE:
10 of 10	3/19/2015