



U.S. Department  
of Transportation  
**Federal Highway  
Administration**

400 Seventh St., S.W.  
Washington, D.C. 20590

JUN 29 1988

REFER TO:  
HNG-14

Mr. Robert A. Sik  
Vice President, Permanent Mold Division  
Akron Foundry Company  
2728 Wingate Avenue  
P.O. Box 27028  
Akron, Ohio 44319-0009

Dear Mr. Sik:

This is in response to your April 1 request for acceptance by the Federal Highway Administration (FHWA) of your company's TB1 series transformer bases for use on Federal-aid highway projects. Tests were conducted to assess the compliance of these bases with Section 7 of the 1985 AASHTO specifications. You enclosed for our review seven Southwest Research Institute reports (Project No. 06-2128-103) dated March 1988, containing pendulum tests on the bases.

The tests used an instrumented 1,800-pound pendulum fitted with a 10 stage crushable nose which simulates a 1979 Volkswagen Rabbit. The measured and extrapolated results from the tests were as follows:

<u>Test No.</u>	<u>Date</u>	<u>Measured change in velocity at 20 m.p.h.</u>	<u>Extrapolated change in velocity at 60 m.p.h.</u>	<u>Stub Height</u>
1.	2-21-88	6.19 fps	8.24 fps	*
2.	2-21-88	7.17 fps	10.23 fps	*
3.	2-21-88	6.44 fps	14.44 fps	*
4A.	2-22-88	10.1 fps	15.76 fps	*
4B.	2-22-88	11.18 fps	16.12 fps	3.06"
5A.	2-22-88	9.33 fps	15.43 fps	5.75"
5B.	2-22-88	9.92 fps	15.61 fps	*

(Tests 4B and 5B are retests of tests 4A and 5A.)

\* Base broke away completely. No remains other than mounting bolts.

Table 1, copy enclosed, lists the various tests and the pole types that were tested using bases TB1-AF 1315-17, TB1-AF 1315-17IW, and TB1-AF Modified-17. The above information shows that the actual tests and calculated changes in velocity of the pole-base combinations shown in Table 1 meet the change in velocity and stub height provisions of Section 7 of the 1985 American Association of State Highway and Transportation Officials (AASHTO) "Standard Specifications for Structural Supports for Highway Signs, Luminaires and Traffic Signals" with the exception of tests 4A through 5B. The FHWA will accept the results of tests 4A through 5B per the following discussion:

The calculated changes in velocity at 60 m.p.h. for the four tests exceed the 15.0 fps specified in AASHTO. The extrapolation formula used to make these estimates is known to usually be conservative. The FHWA is currently undergoing a rulemaking process to adopt Section 7 of the 1985 AASHTO specifications for breakaway devices for use on Federal-aid highway projects. The FHWA anticipates accepting breakaway devices which cause a change in velocity up to 16 feet per second. The extrapolated changes in velocity for tests 4A, 4B, 5A, and 5B are below, or round to meet the 16 foot per second velocity change requirement. The non-conforming stub height of test 5A resulted in a retest. Test 5B showed compliance to the stub height requirement.

The bases shown in Table 1 and the enclosed drawings (2) are acceptable for use on Federal-aid projects, within the range of conditions tested, if proposed by a State. The acceptance is limited to breakaway characteristics of the bases and does not cover their structural features. Presumably, you will supply potential users with sufficient information on structural design and installation requirements to ensure proper base performance.

The FHWA is currently in the process of formally adopting Section 7 of the 1985 AASHTO specification. A change of velocity criterion of 16.0 fps instead of 15.0 fps, and a transition period for full implementation of approximate 18 months are being considered. Because these actions are not yet finalized, this acceptance must be somewhat limited. Should the lower acceptance level be adopted, our acceptance of those supports not meeting the adopted level will expire at the end of the transition period. On the other hand, if the FHWA's final rule on breakaway sets the acceptance level at 16 fps or higher our limitation on this acceptance will not be applicable.

We anticipate that the States will require certification from Akron Foundry Company that castings furnished have essentially the same chemistry, mechanical properties, and geometry as the castings used in the tests and that the castings will meet the FHWA change in velocity requirements.

Sincerely yours,



L. A. Staron  
Chief, Federal-Aid and Design Division

Enclosures

\*\*\*\*\*

Test Number	Base Number	Top Bolt Circle Diameter	Bottom Bolt Circle Diameter	Pole Type	Pole Height	Weight W/Arm & Dummy	Nominal Luminaire Mounting Height	Top Washers Outside Diameter	Top Washers Inside Diameter
1	TB1-AF 1315-17	13"	15"	ALUMINUM	35'	437 #	42.0'	2 1/2"	1 1/16"
2	TB1-AF 1315-17 IW	13"	15"	ALUMINUM	44.5'	511 #	51.2'	2 1/2"	1 1/16"
3	TB1-AF 1315-17	13"	15"	STEEL	35'	832 #	42.0"	2 1/2"	1 1/16"
4A	TB1-AF 1315-17 IW	13"	15"	STEEL	44.5'	778 #	50.0"	2 1/2"	1 1/16"
4B	TB1-AF 1315-17 IW	13"	15"	STEEL	44.5'	778 #	50.0"	2 1/2"	1 1/16"
5A	TB1-AF MODIFIED-17	12"	10.5"	STEEL	35'	832 #	42.0'	2 1/2"	1 1/16"
5B	TB1-AF MODIFIED-17	12"	10.5"	STEEL	35'	832 #	42.0'	2 1/2"	1 1/16"

\*\*\*\*\*

"IW" refers to an internal weld inside the base \* assembly also requires rectangular

\*\*\*\*\*

TABLE NUMBER 1

\* ALL WASHERS TO BE ZINC MECHANICAL COATED PER ASTM B 695 - 85 CLASS 50

CHEMICAL & PHY. CERTS TO BE SUPPLIED WITH EACH SHIPMENT

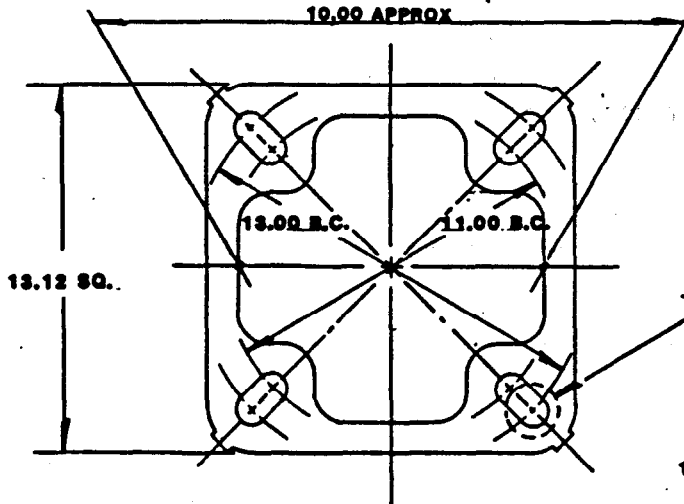

- \* 2 1/2 DIA. X 3/8 THK. 1 1/16 LD. STEEL WASHER
- FOR 1" DIA. ANCHOR CONNECTING BOLTS OR
- 2 3/4 DIA. X 1/2 THK. WITH EITHER 1 1/16 OR 1 5/16 LD. STEEL WASHERS FOR EITHER 1" OR 1 1/4 DIA. CONNECTING BOLTS

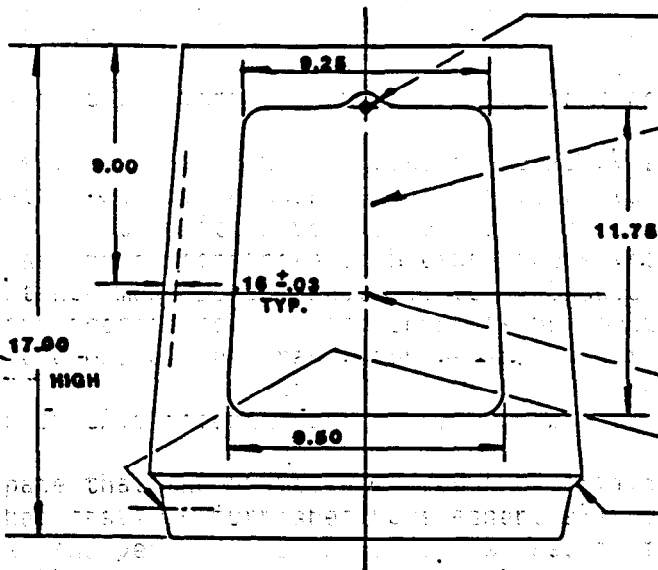

1/4-20 HEX HD. 1/2" LG. S.S. SCREW

ADHESIVE BREAKAWAY AND CAUTION INSTRUCTION LABELS APPEAR INSIDE WALL OPPOSITE DOOR OPENING

GROUND SCREW HOLE 1/4-20 TAP THRU

GROUND SCREW HOLE 1/2-13 TAP THRU

1/4" MIG 4043 WIRE

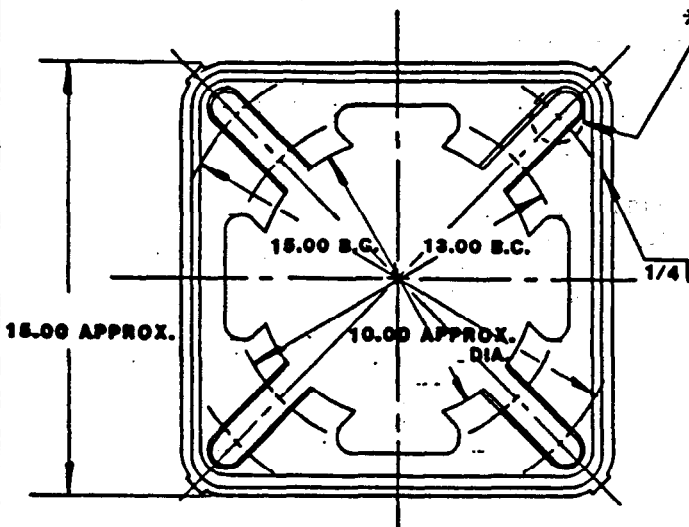

- \* 2 3/4 DIA. X 1/2 THK. 1 1/16 LD. STEEL WASHER FOR 1" DIA. BOLTS OR 2 3/4 DIA. X 1/2 THK. 1 5/16 LD. STEEL WASHER FOR 1 1/4 DIA. BOLTS

WHEN INTERNAL WELD IS REQUIRED:  
4043 WIRE WITH APPROX 5" OF WELD ON EACH OF THE (4) INTERNAL CORNERS  
ORDER PART NO. WITH SUFFIX LW. FOR INTERNAL WELDED CORNERS

S.S. WHEELABRATED FINISH  
306-T6

**AKRON FOUNDRY CO.**

AL. BREAKAWAY TRANSFORMER BASE

DATE 1-25-88  
DWN. SIK

TB1-AF1315-17  
REVISED FOR 1800 ♂ PENDULUM

TEST #1 TO 4B

\* ALL WASHERS TO BE ZINC MECHANICAL COATED PER ASTM B 695-85 CLASS 50

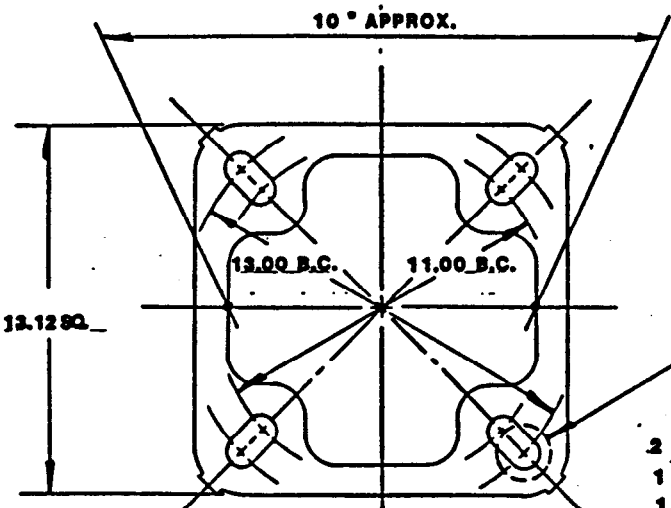

CHEMICAL & PHY. CERTS TO BE SUPPLIED WITH EACH SHIPMENT.

\* 2 1/2 DIA. X 3/8 THK. 1 1/16 LD. STEEL WASHER FOR 1" DIA. CONNECTING BOLTS  
OR  
2 3/4 DIA. X 1/2 THK. WITH EITHER 1 1/16 OR 1 5/16 I.D. STEEL WASHER FOR EITHER 1" OR 1 1/4 DIA. CONNECTING BOLTS

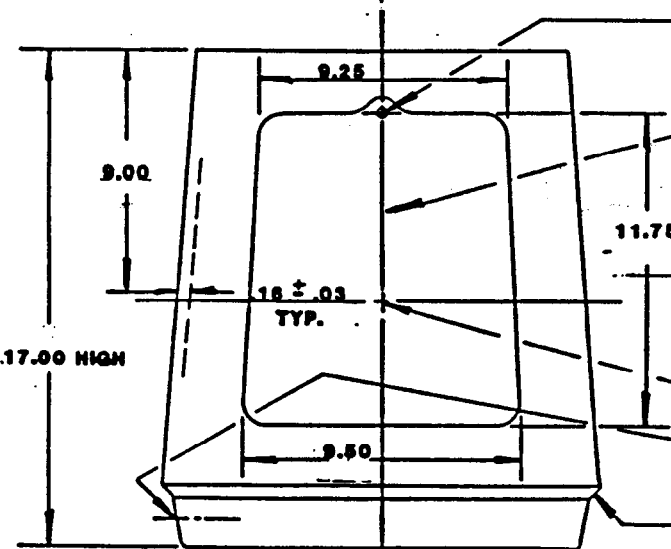

1/4-20 HEX HD. 1/2" LG. S.S. SCREW

ADHESIVE BREAKAWAY AND CAUTION INSTRUCTION LABELS APPEAR INSIDE WALL OPPOSITE DOOR OPENING ALONG WITH SPECIAL MOUNTING INSTRUCTION LABEL

GROUND SCREW HOLE 1/4 - 20 TAP THRU  
GROUND SCREW HOLE 1/2 - 13 TAP THRU

1/4" MIG 4043 WIRE

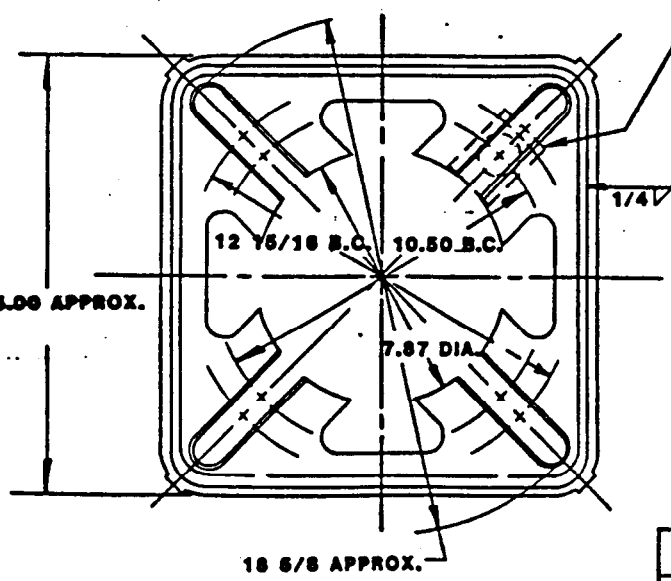

\* 2 1/2 DIA. X 3/8 THK. 1 1/16 LD. STEEL WASHER AND 2 3/4 X 4 1/4 X 5/8 THK. RECTANGULAR WASHER.

1/4" 4043 WIRE WITH APPROX 5" OF WELD ON EACH OF THE (4) INTERNAL CORNERS

S.S. WHEELABRATED FINISH  
356-T6

<b>AKRON FOUNDRY CO.</b>	
AL. BREAKAWAY TRANSFORMER BASE	
DATE 3-1-88	<b>TB1-MODIFIED -17</b>
DWN. -SK	
REVISED FOR 1800 P PENDULUM	

**TEST #5A&B**