



U.S. Department
of Transportation
**Federal Highway
Administration**

August 27, 2021

1200 New Jersey Ave., SE
Washington, D.C. 20590

In Reply Refer To:
HSST-1/B-362

Mathias Redlberger
REBLOC GmbH
Wiener Straße 662
3571 Gars am Kamp
Austria

Dear Mr Redlberger:

This letter is in response to your December 2, 2020 request for the Federal Highway Administration (FHWA) to review a roadside safety device, hardware, or system for eligibility for reimbursement under the Federal-aid highway program. This FHWA letter of eligibility is assigned FHWA control number B-362 and is valid until a subsequent letter is issued by FHWA that expressly references this device.

Decision

The following device is eligible within the length-of-need, with details provided in the form which is attached as an integral part of this letter:

- Transition REBLOC 80SAH_12<>80SAH_12_8B

Scope of this Letter

To be found eligible for Federal-aid funding, new roadside safety devices should meet the crash test and evaluation criteria contained in the American Association of State Highway and Transportation Officials' (AASHTO) Manual for Assessing Safety Hardware (MASH). However, the FHWA, the Department of Transportation, and the United States Government do not regulate the manufacture of roadside safety devices. Eligibility for reimbursement under the Federal-aid highway program does not establish approval, certification or endorsement of the device for any particular purpose or use.

This letter is not a determination by the FHWA, the Department of Transportation, or the United States Government that a vehicle crash involving the device will result in any particular outcome, nor is it a guarantee of the in-service performance of this device. Proper manufacturing, installation, and maintenance are required in order for this device to function as tested.

This finding of eligibility is limited to the crashworthiness of the system and does not cover other structural features, nor conformity with the Manual on Uniform Traffic Control Devices.

Eligibility for Reimbursement

Based solely on a review of crash test results and certifications submitted by the manufacturer, and the crash test laboratory, FHWA agrees that the device described herein meets the crash test and evaluation criteria of the AASHTO's MASH. Therefore, the device is eligible for reimbursement under the Federal-aid highway program if installed under the range of tested conditions.

- Name of system: Transition REBLOC 80SAH_12<>80SAH_12_8B
Type of system: Longitudinal Barrier
Test Level: Test Level 3
Testing conducted by: crashtest-service.com GmbH
Date of request: December 2, 2020

FHWA concurs with the recommendation of the accredited crash testing laboratory on the attached form.

Full Description of the Eligible Device

The device and supporting documentation, including reports of the crash tests or other testing done, videos of any crash testing, and/or drawings of the device, are described in the attached form.

Notice

This eligibility letter is issued for the subject device as tested. Modifications made to the device are not covered by this letter. Any modifications to this device should be submitted to the user (i.e., state DOT) as per their requirements.

You are expected to supply potential users with sufficient information on design, installation and maintenance requirements to ensure proper performance.

You are expected to certify to potential users that the hardware furnished has the same chemistry, mechanical properties, and geometry as that submitted for review, and that it will meet the test and evaluation criteria of AASHTO's MASH.

Issuance of this letter does not convey property rights of any sort or any exclusive privilege. This letter is based on the premise that information and reports submitted by you are accurate and correct. We reserve the right to modify or revoke this letter if: (1) there are any inaccuracies in the information submitted in support of your request for this letter, (2) the qualification testing was flawed, (3) in-service performance or other information reveals safety problems, (4) the system is significantly different from the version that was crash tested, or (5) any other information indicates that the letter was issued in error or otherwise does not reflect full and complete information about the crashworthiness of the system.

Standard Provisions

- To prevent misunderstanding by others, this letter of eligibility designated as FHWA control number B-362 shall not be reproduced except in full. This letter and the test documentation upon which it is based are public information. All such letters and documentation may be reviewed upon request.
- This letter shall not be construed as authorization or consent by the FHWA to use, manufacture, or sell any patented system for which the applicant is not the patent holder.
- This FHWA eligibility letter is not an expression of any Agency view, position, or determination of validity, scope, or ownership of any intellectual property rights to a specific device or design. Further, this letter does not impute any distribution or licensing rights to the requester. This FHWA eligibility letter determination is made based solely on the crash-testing information submitted by the requester. The FHWA reserves the right to review and revoke an earlier eligibility determination after receipt of subsequent information related to crash testing.

Sincerely,

Michael S. Griffith

Michael S. Griffith
Director, Office of Safety Technologies
Office of Safety

Enclosures

Request for Federal Aid Reimbursement Eligibility of Highway Safety Hardware

Submitter	Date of Request:	December 02, 2020	<input checked="" type="radio"/> New <input type="radio"/> Resubmission
	Name:	Mathias Redlberger	
	Company:	REBLOC GmbH	
	Address:	Wiener Straße 662, 3571 Gars am Kamp	
	Country:	Austria	
	To:	Michael S. Griffith, Director FHWA, Office of Safety Technologies	

I request the following devices be considered eligible for reimbursement under the Federal-aid highway program.

Device & Testing Criterion - Enter from right to left starting with Test Level

!-!-!

System Type	Submission Type	Device Name / Variant	Testing Criterion	Test Level
'B': Rigid/Semi-Rigid Barriers (Roadside, Median, Bridge Railings)	<input checked="" type="radio"/> Physical Crash Testing <input type="radio"/> Engineering Analysis	Transition REBLOC 80SAH_12<>80SAH_12_8B	AASHTO MASH	TL3

By submitting this request for review and evaluation by the Federal Highway Administration, I certify that the product(s) was (were) tested in conformity with the AASHTO Manual for Assessing Safety Hardware and that the evaluation results meet the appropriate evaluation criteria in the MASH.

Individual or Organization responsible for the product:

Contact Name:	Mathias Redlberger	Same as Submitter <input checked="" type="checkbox"/>
Company Name:	REBLOC GmbH	Same as Submitter <input checked="" type="checkbox"/>
Address:	Wiener Straße 662, 3571 Gars am Kamp	Same as Submitter <input checked="" type="checkbox"/>
Country:	Austria	Same as Submitter <input checked="" type="checkbox"/>
Enter below all disclosures of financial interests as required by the FHWA 'Federal-Aid Reimbursement Eligibility Process for Safety Hardware Devices' document.		
<p>Crashtest-service.com GmbH (CTS) was contracted by REBLOC GmbH to perform full-scale crash testing of the Transition REBLOC 80SAH_12<>80SAH_12_8B barrier. There are no shared financial interests in the Transition REBLOC 80SAH_12<>80SAH_12_8B barrier by CTS, or between REBLOC GmbH and CTS, other than costs involved in the actual crash tests and reports for this submission to FHWA.</p>		

REBLOC
 R E B L O C G M B H
 Wienerstraße 662 · A-3571 Gars am Kamp
 Tel. +43(2985)30528 2900 · Fax +43(2985)30528 2901
 office@rebloc.com · www.rebloc.com

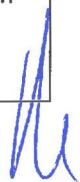

PRODUCT DESCRIPTION

New Hardware or Significant Modification
 Modification to Existing Hardware

This transition connects the free standing system REBLOC 80SAH_12 with the anchored system REBLOC 80SAH_12_8B (anchored with 8 screwbolts). It consists of the same factory produced precast elements as the two connected systems. Each element is 12.0m (472.4 in) long, 0.3m (11.8 in) wide and 0.8m (31.5 in) high. The precast concrete elements have a cross section similar to an I-beam profile.

The transition element is anchored with 4 screwbolts. When tested it was connected to 7 elements of free standing REBLOC 80SAH_12 and 3 anchored elements REBLOC 80SAH_12_8B.

CRASH TESTING

By signature below, the Engineer affiliated with the testing laboratory, agrees in support of this submission that all of the critical and relevant crash tests for this device listed above were conducted to meet the MASH test criteria. The Engineer has determined that no other crash tests are necessary to determine the device meets the MASH criteria.

Engineer Name:	Peter Schimmelpfennig	
Engineer Signature:	Peter Schimmelpfennig <small>Digital unterschrieben von Peter Schimmelpfennig Datum: 2020.12.02 14:32:19 +01'00'</small>	
Address:	Amelunxenstraße 30, 48167 Münster	Same as Submitter <input type="checkbox"/>
Country:	Germany	Same as Submitter <input type="checkbox"/>

A brief description of each crash test and its result:

Required Test Number	Narrative Description	Evaluation Results
3-10 (1100C)		Non-Relevant Test, not conducted
3-11 (2270P)		Non-Relevant Test, not conducted
3-20 (1100C)		Non-Relevant Test, not conducted
3-21 (2270P)	Test nr. 19442. Test report nr. 12184-3272-19442-EN performed 27-AUG-2020 by crashtest-Service.com. The longitudinal concrete barrier contained and redirected the 2270P vehicle. The vehicle did not penetrate, underride or override the installation. Maximum dynamic deflection during the test was 0.31 m (12.2 in). No significant parts separated neither from the vehicle nor the barrier. No occupant compartment deformation or intrusion occurred. The vehicle remained upright during and after the impact.	PASS

Full Scale Crash Testing was done in compliance with MASH by the following accredited crash test laboratory (cite the laboratory's accreditation status as noted in the crash test reports.):



REBLOC
 R E B L O C G M B H
 Wienerstraße 662 · A-3571 Gars am Kamp
 Tel. +43(2985)30528 2900 · Fax +43(2985)30528 2901
 office@rebloc.com · www.rebloc.com

Laboratory Name:	crashtest-service.com GmbH	
Laboratory Signature:	Peter Schimmelpfennig	Digital unterschrieben von Peter Schimmelpfennig Datum: 2020.12.02 14:32:33 +01'00'
Address:	Amelunxenstraße 30, 48167 Münster	Same as Submitter <input type="checkbox"/>
Country:	Germany	Same as Submitter <input type="checkbox"/>
Accreditation Certificate Number and Dates of current Accreditation period :	D-PL-17359-01-00 02-MAY-2018 - 01-MAY-2023	

Submitter Signature*:  **Rebloc GmbH**
2020.12.03 12:15:47
+01'00'

Submit Form

ATTACHMENTS

Attach to this form:

- 1) Additional disclosures of related financial interest as indicated above.
- 2) A copy of the full test report, video, and a Test Data Summary Sheet for each test conducted in support of this request.
- 3) A drawing or drawings of the device(s) that conform to the Task Force-13 Drawing Specifications [[Hardware Guide Drawing Standards](#)]. For proprietary products, a single isometric line drawing is usually acceptable to illustrate the product, with detailed specifications, intended use, and contact information provided on the reverse. Additional drawings (not in TF-13 format) showing details that are relevant to understanding the dimensions and performance of the device should also be submitted to facilitate our review.

FHWA Official Business Only:

Eligibility Letter		
Number	Date	Key Words

REBLOC
R E B L O C G M B H
Wienerstraße 662 · A-3571 Gars am Kamp
Tel. +43(2985)30528 2900 · Fax +43(2985)30528 2901
office@rebloc.com · www.rebloc.com



1. Sequential Photographs



2. Plan View

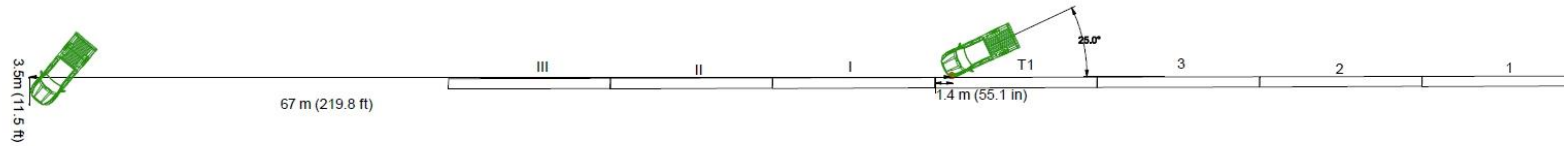

3. Cross-Sectional View

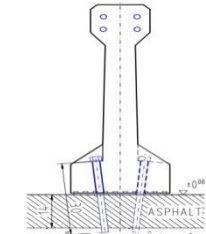

4. General Information

Test Agency	crashtest-service.com GmbH (CTS)
Test Standard	MASH Test TL 3-21
CTS-Test No	19442
Date	27-AUG-2020

5. Test Article

Type	Concrete barrier transition	
Name	"TR REBLOC 80SAH_12 <> 80SAH_12_8B"	
Installation Length	84.0 m (3307 in)	
Key Elements - Barrier	Length:	12.0 m (472 in)
	Base height:	0.8 m (12 in)
	Width:	0.3 m (31 in)

6. Soil Type and Condition

Type of Soil	Asphalt
Soil Strength	---
Condition	Dry, cloudy, 22.3 °C

7. Test Vehicle

Type/Designation	2270P	
Make and Model	Dodge Ram 1500 Pickup	
Curb	2177	kg (4799 lb)
Test Inertial	2260	kg (4982 lb)
Dummy	---	kg (--- lb)
Gross Static	3085	kg (6801 lb)

8. Impact Conditions

Speed	99.7	km/h (61.9 mph)
Angle	24.9	degrees
Location/Orientation	1.38	m (54.3 in) before transition of T1/I

9. Exit Conditions

Speed	82	km/h (50.9 mph)
Angle	7	degrees

10. Post-Impact Trajectory

Vehicle Stability	(Satisfactory)	
Stopping Distance	67	m (2638 in) downstream
	3.5	m (138 in) laterally behind

Vehicle Snagging	No
Vehicle Pocketing	No

11. Occupant Risk

Impact Velocity		
Longitudinal	- 4.28	m/s (14.1 ft/s)
Lateral	7.19	m/s (23.6 ft/s)
Ridedown Accelerations (10 msec avg.)		
Longitudinal	- 4.22	g
Lateral	3.54	g

THIV	8.4	m/s (27.6 ft/s)
PHD	16.35	g
ASI	1.48	
12. Test Article Damage		
Classification	Moderate	
particularities	None	
13. Test Article Deflections		
Dynamic Deflection	0.31	m (12.2 in)
Permanent Deflection	0.01	m (0.4 in)
Dynamic Working Width	0.58	m (22.8 in)
Permanent Working Width	0.31	m (12.2 in)
14. Vehicle Damage		
Classification	Moderate	
VDS	11-LFQ-4	
CDC	11FDEW4	
Max. Exterior Deformation	246 mm (9.69 in)	
Max. Interior Deformation	16 mm (0.63 in)	
OCDI	ND0000000	

TR REBLOC 80SAH_12 <> 80SAH_12_8B

Temporary System - transition element

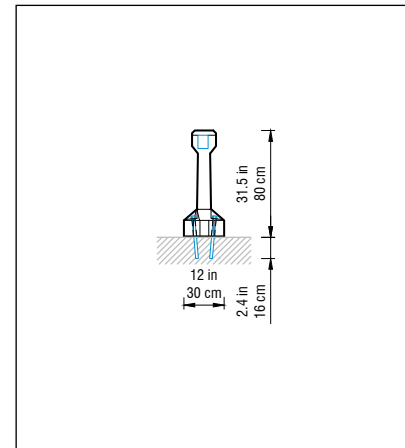
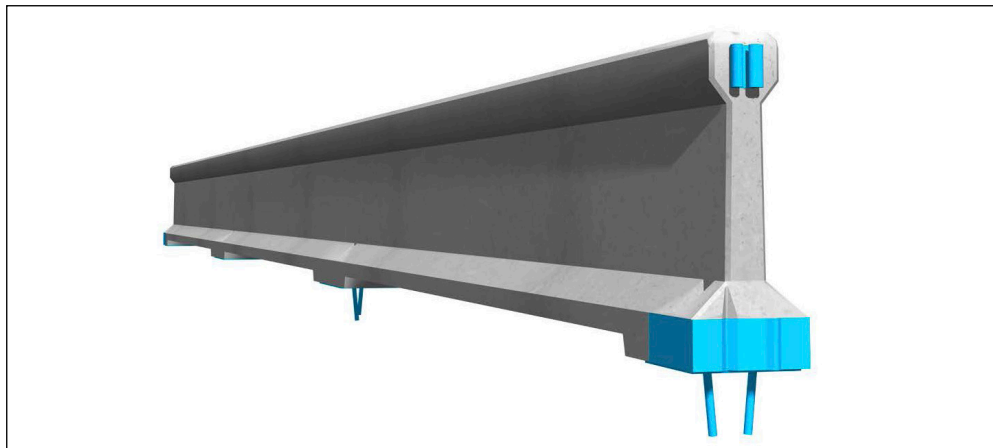
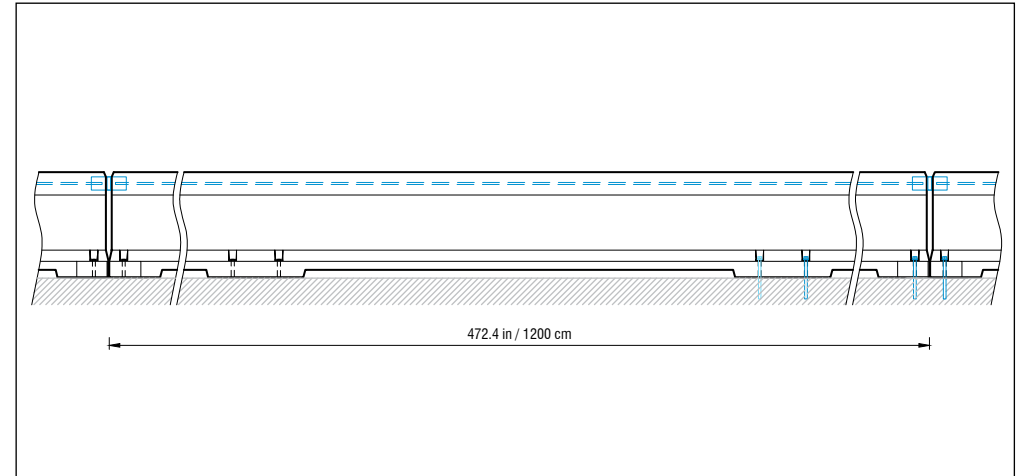
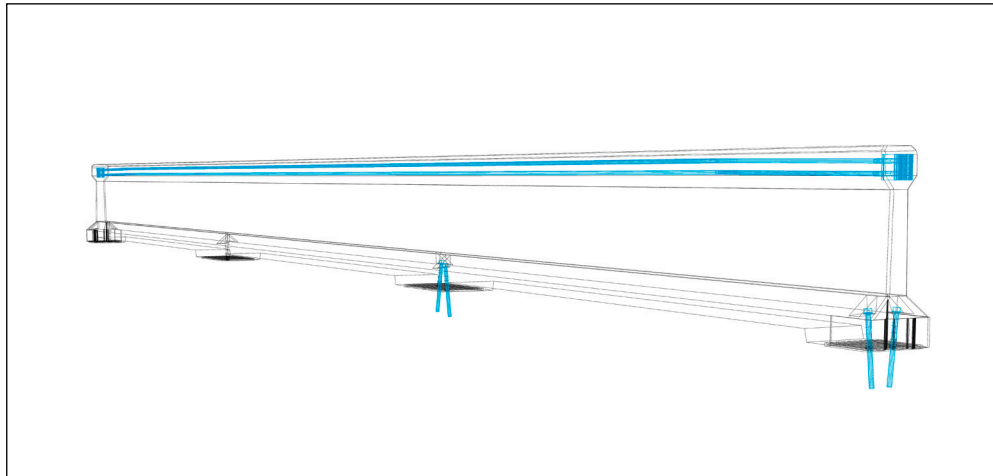

The element is connected by the integrated coupling, located at the face of the element.

Element	Transition 80SAH_12
Dimensions	472 1/2" x 12" x 31 1/2" (1200 x 30 x 80 cm)
Weight/element	7496 lb (3400 kg)
Material	Concrete 5000 psi
Date	2021-03-16