

NOTE:

1. Install fasteners according to the manufacturer's recommendations.
2. Overlap in the direction of the prevailing wind.

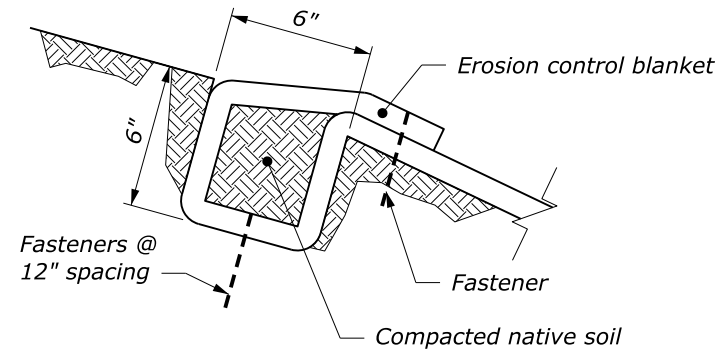

**DETAIL A
ANCHOR TRENCH
AT TOP OF SLOPE**

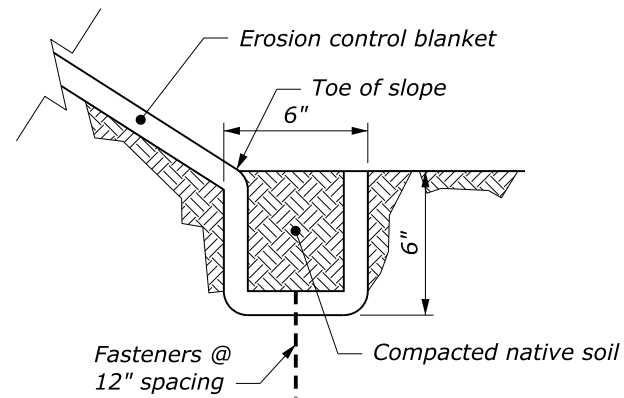

**DETAIL B
ANCHOR TRENCH
AT TOE OF SLOPE**

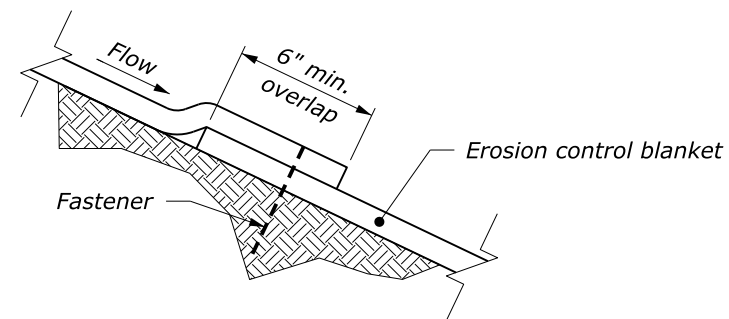

**DETAIL C
SHINGLE SPLICE**

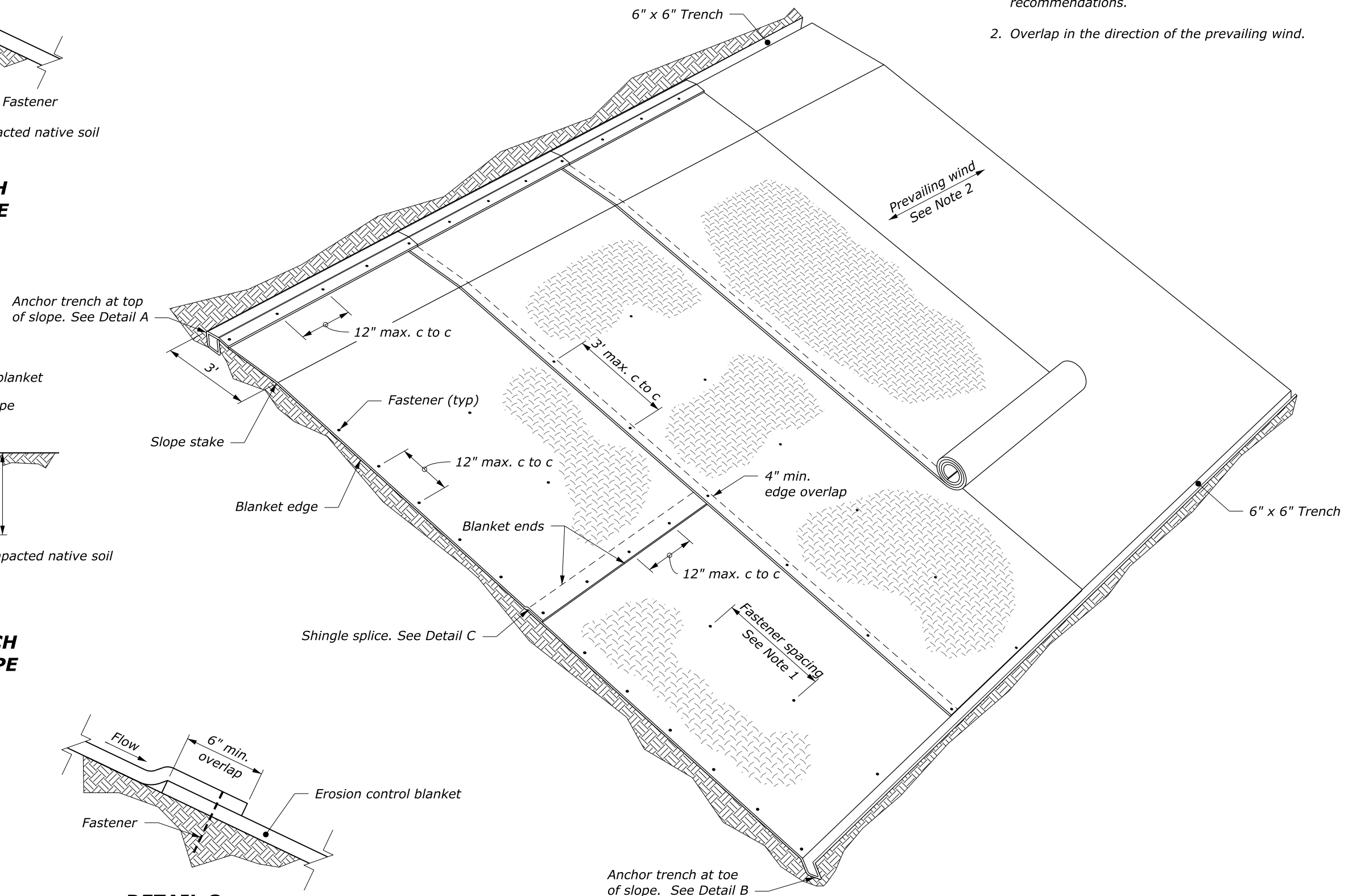

PERSPECTIVE VIEW

NO SCALE

U.S. DEPARTMENT OF TRANSPORTATION, FHWA OFFICE OF FEDERAL LANDS HIGHWAY	WFL STANDARD W629-1
ROLLED EROSION CONTROL PRODUCT ON SLOPES	SPECIFICATION FP-24
	APPROVED FOR USE 8/2024

NOTE:

1. Install fasteners according to the manufacturer's recommendations.
2. Overlap in the direction of the prevailing wind.

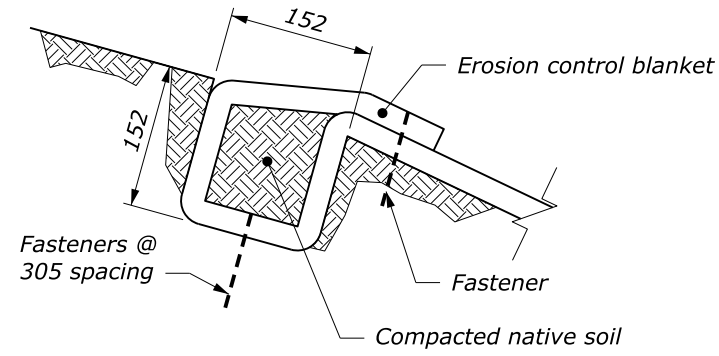

**DETAIL A
ANCHOR TRENCH
AT TOP OF SLOPE**

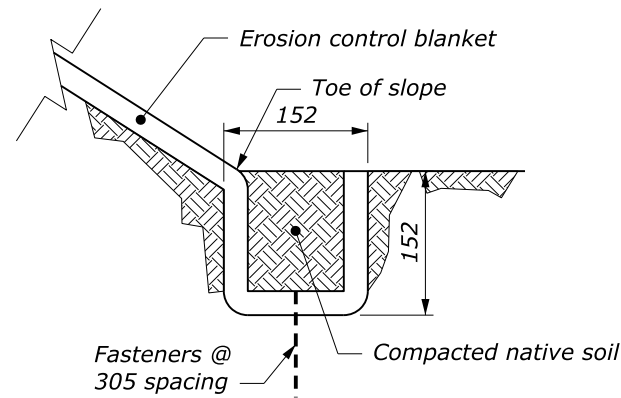

**DETAIL B
ANCHOR TRENCH
AT TOE OF SLOPE**

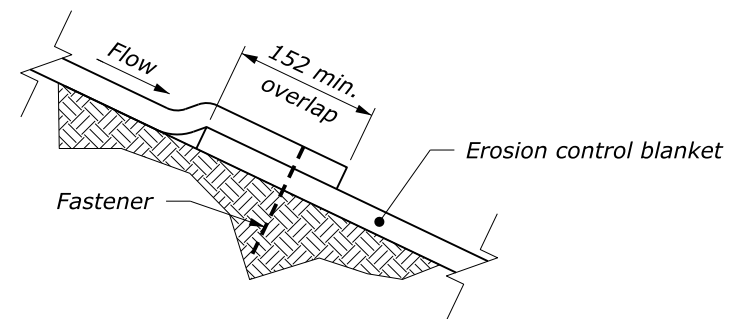

**DETAIL C
SHINGLE SPLICE**

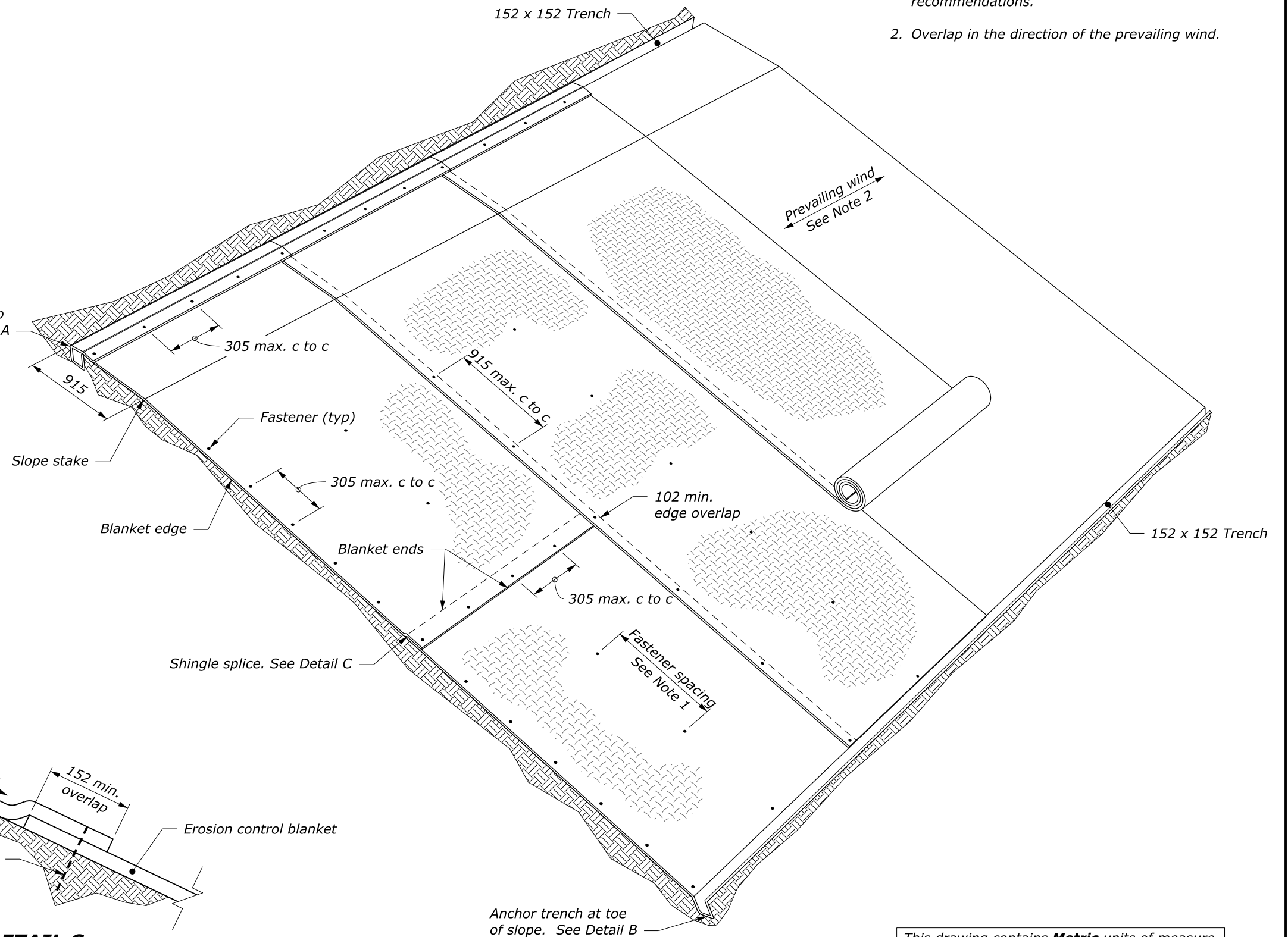

PERSPECTIVE VIEW

NO SCALE

This drawing contains **Metric** units of measure.
Dimensions without units are millimeters.

U.S. DEPARTMENT OF TRANSPORTATION, FHWA OFFICE OF FEDERAL LANDS HIGHWAY	WFL STANDARD WM629-1
ROLLED EROSION CONTROL PRODUCT ON SLOPES	SPECIFICATION FP-24
	APPROVED FOR USE 8/2024

NOTE:

1. Install fasteners according to the manufacturer's recommendations.
2. Provide check slots according to the manufacturer's recommendations.
3. Roll ends may be spliced in a check slot.
4. Trapezoidal ditch shown. Similar details for a V-ditch.

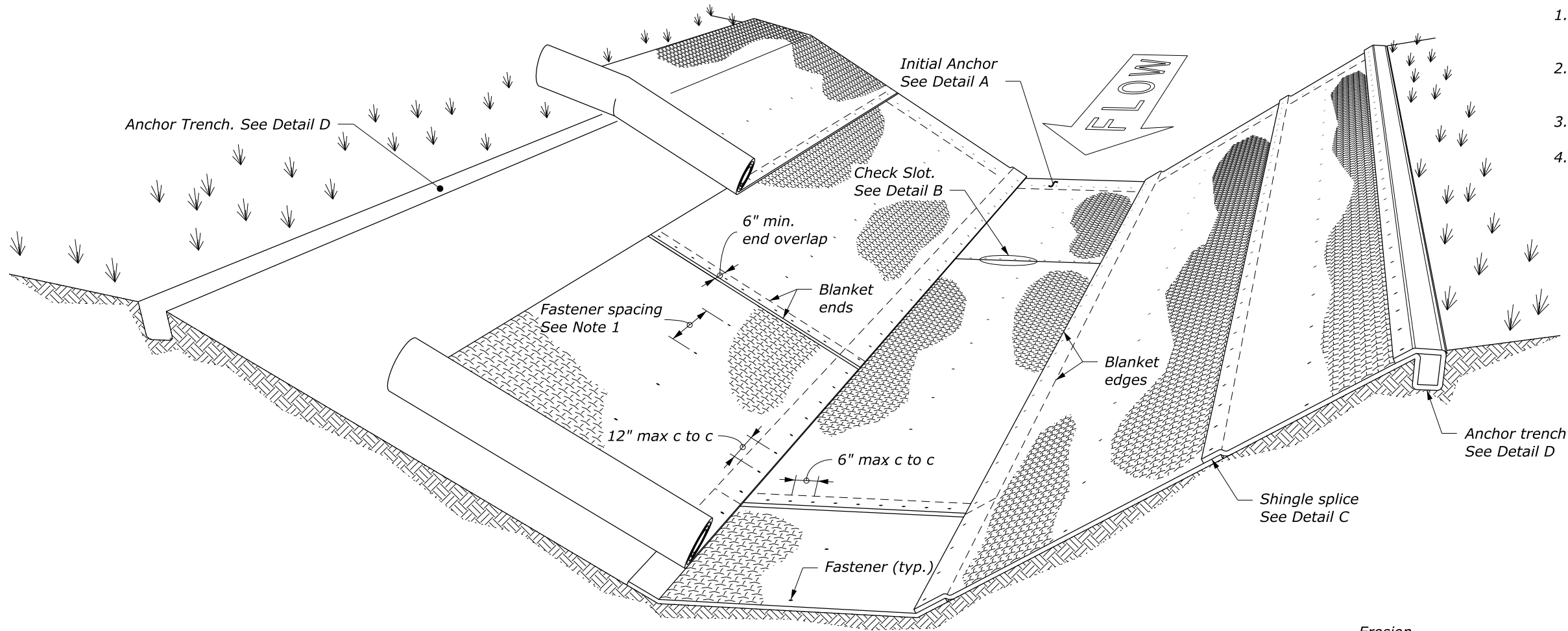

PERSPECTIVE VIEW

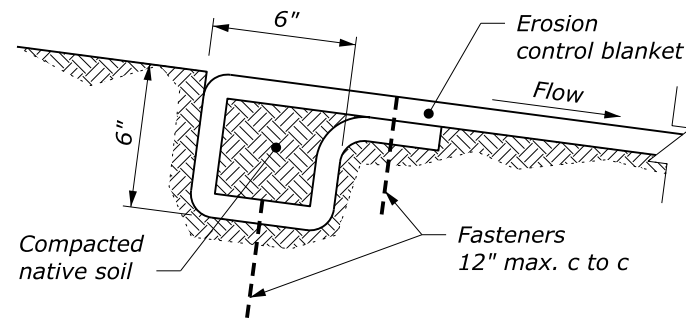

**DETAIL A
INITIAL ANCHOR**

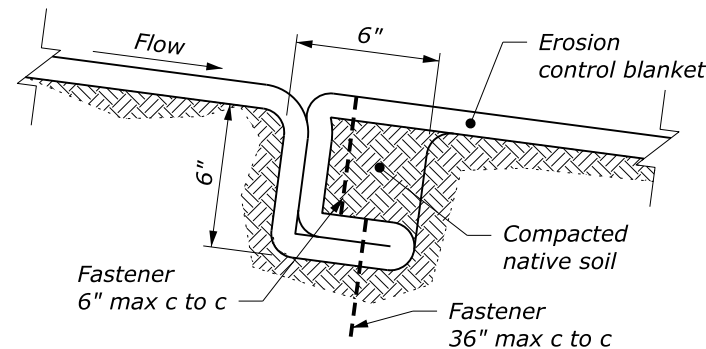

**DETAIL B
CHECK SLOT**
See Note 2

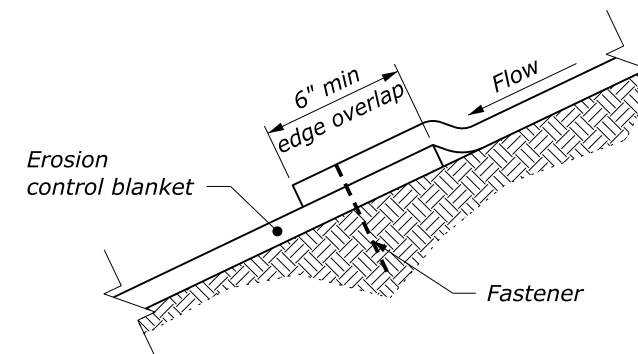

**DETAIL C
SHINGLE SPLICE**

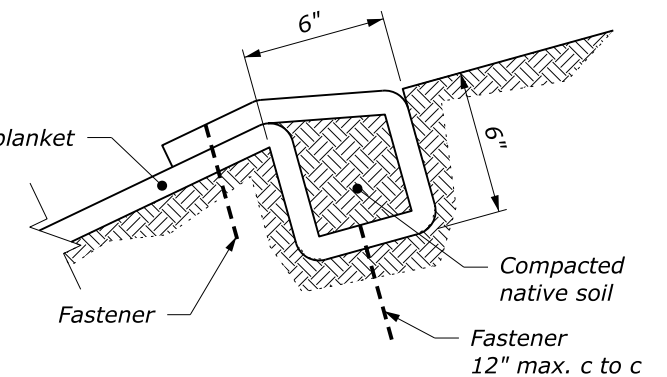

**DETAIL D
ANCHOR TRENCH**

NO SCALE

U.S. DEPARTMENT OF TRANSPORTATION, FHWA OFFICE OF FEDERAL LANDS HIGHWAY	WFL STANDARD W629-2
ROLLED EROSION CONTROL PRODUCT IN CHANNELS	SPECIFICATION FP-24
	APPROVED FOR USE 8/2024

NOTE:

1. Install fasteners according to the manufacturer's recommendations.
2. Provide check slots according to the manufacturer's recommendations.
3. Roll ends may be spliced in a check slot.
4. Trapezoidal ditch shown. Similar details for a V-ditch.

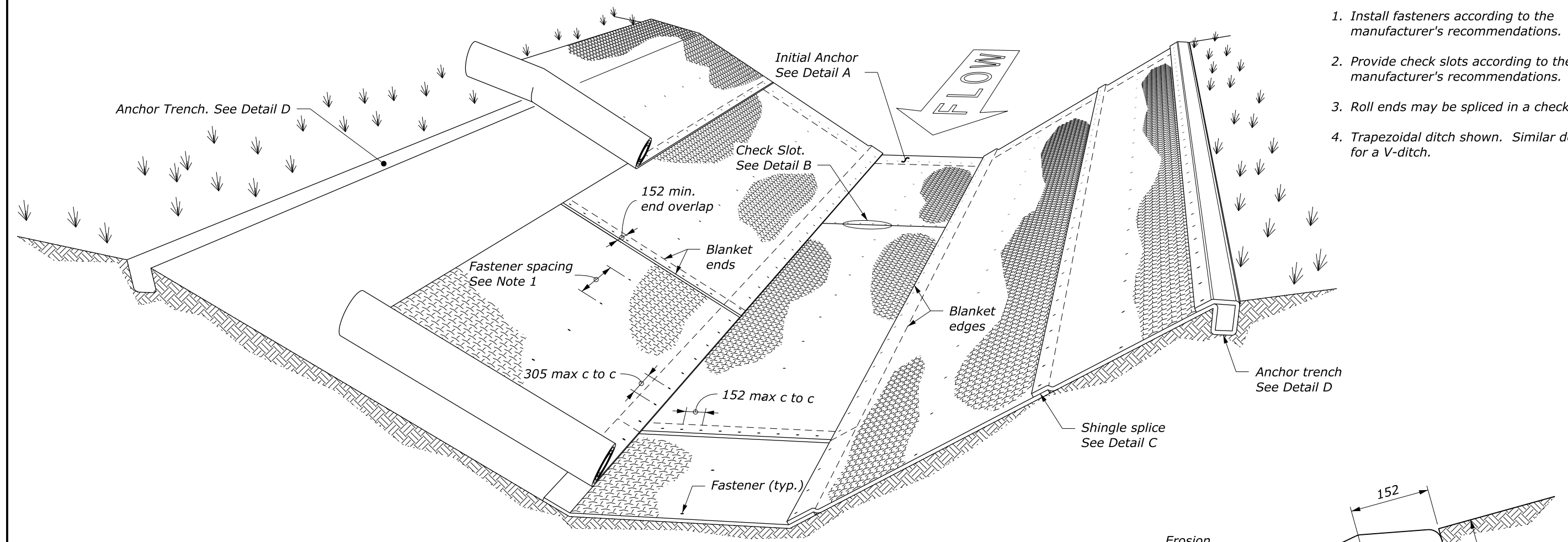

PERSPECTIVE VIEW

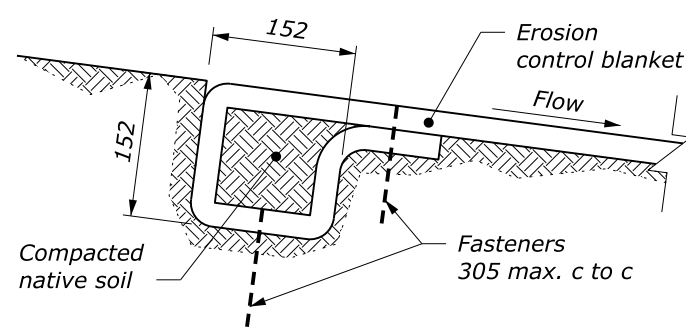

**DETAIL A
INITIAL ANCHOR**

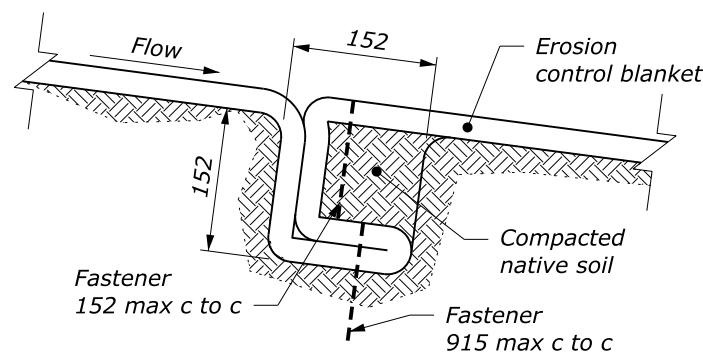

**DETAIL B
CHECK SLOT**
See Note 2

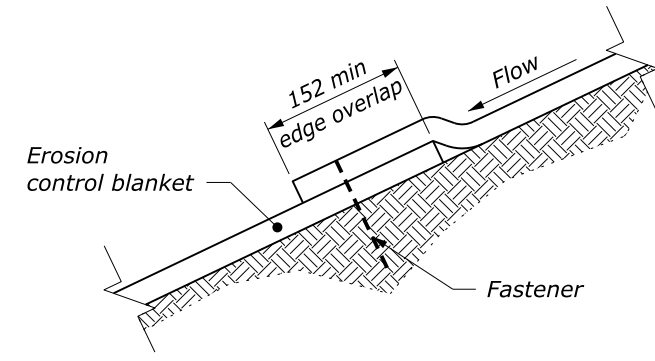

**DETAIL C
SHINGLE SPLICE**

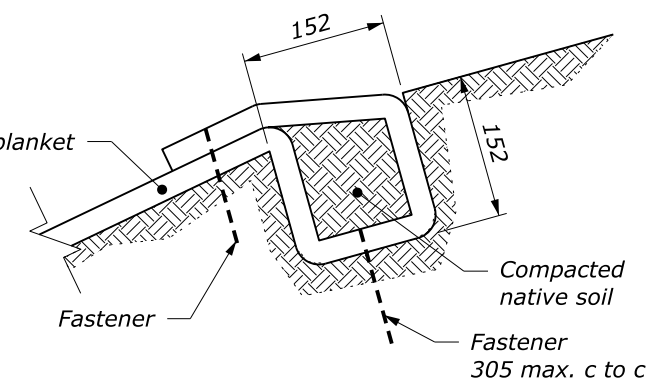

**DETAIL D
ANCHOR TRENCH**

This drawing contains **Metric** units of measure. Dimensions without units are millimeters.

NO SCALE

U.S. DEPARTMENT OF TRANSPORTATION, FHWA OFFICE OF FEDERAL LANDS HIGHWAY	WFL STANDARD WM629-2
ROLLED EROSION CONTROL PRODUCT IN CHANNELS	SPECIFICATION FP-24
	APPROVED FOR USE 8/2024