

Notes to the Designer

Updated February 2024

Delineators

General Information

- Printing should be done from the **[Sheet]** View model

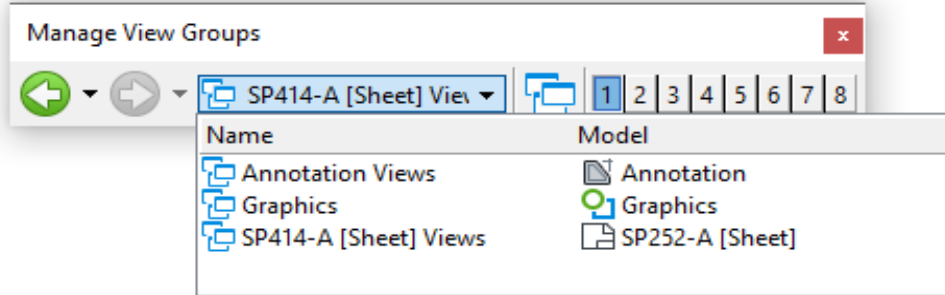

- **Appropriate Applications.** Delineators are considered guidance devices rather than warning devices (MUTCD, Section 3G.01, Line 02). Refer to the MUTCD Chapter 3G.

Applicable SCRs

- None

Typical Pay Item Used

- 63309-0100 Delineator, type 1 [EA] or 63309-0200, type 2 [EA]

Updates

- **March 2011**
 - New CFL Detail drawing
- **August 2014**
 - Updated for FP-14
 - Updated Border
- **August 2021**
 - Updated for OpenRoads Designer
- **February 2024**
 - Updated border; Updated for FP24

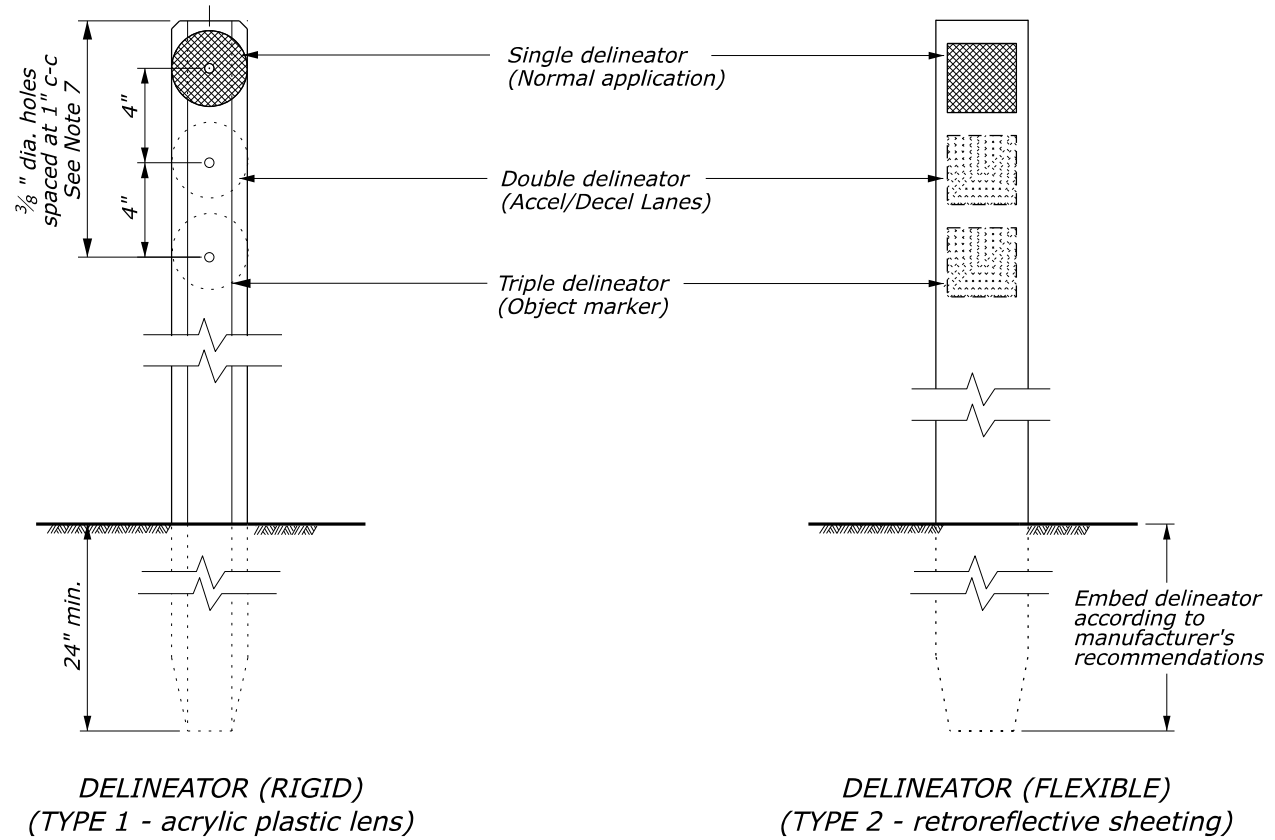

POST DETAILS

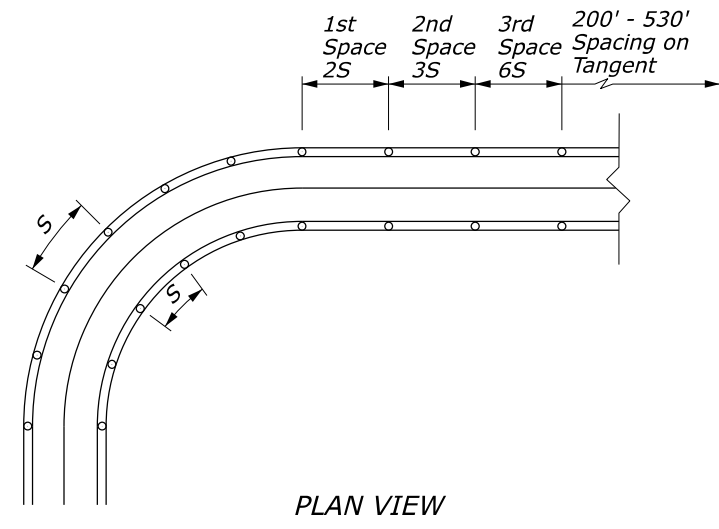
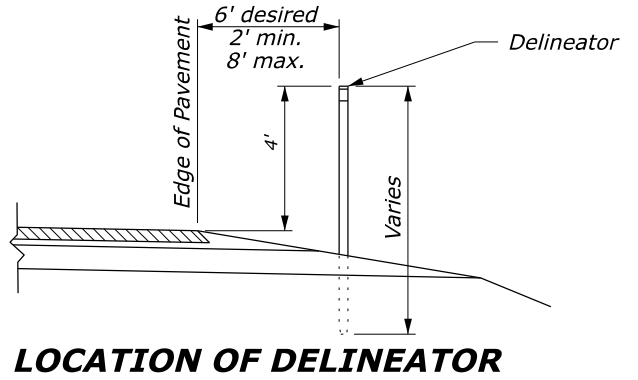
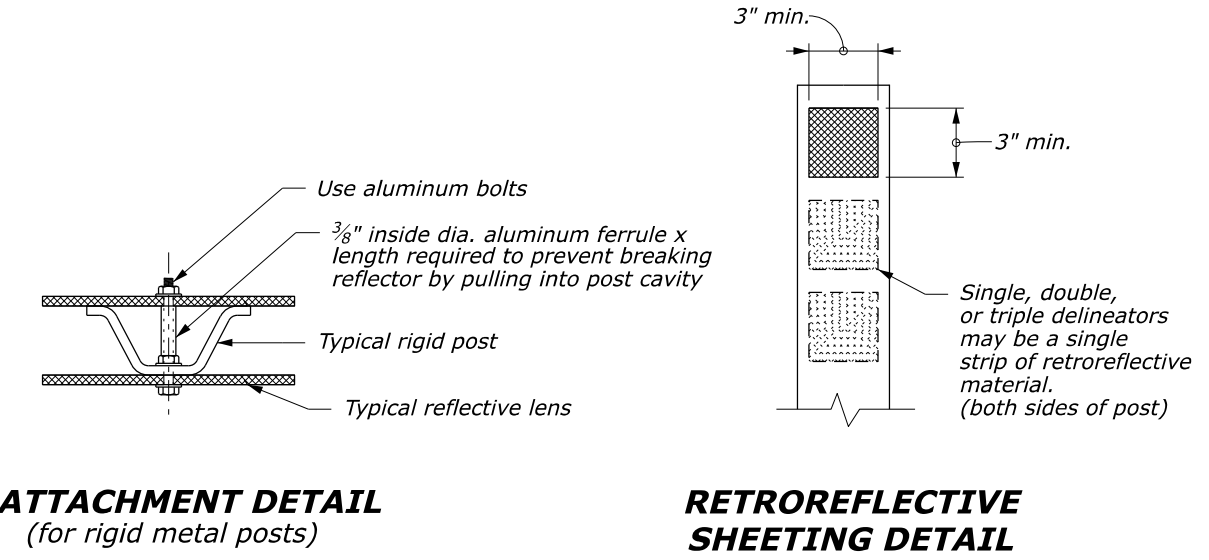

DELINEATOR SPACING ON CURVES				
RADIUS OF CURVE (R)	SPACING ON CURVE (S)	SPACING ON TANGENTS AT CURVE ENDS		
		1st Space (2 S)	2nd Space (3 S)	3rd Space (6 S)
(feet)	(feet)	(feet)	(feet)	(feet)
50	20	40	60	120
115	25	50	75	150
180	35	70	105	210
250	40	80	120	240
300	50	100	150	300
400	55	110	165	300
500	65	130	195	300
600	70	140	210	300
700	75	150	225	300
800	80	160	240	300
900	85	170	255	300
1,000	90	180	270	300

- DELINEATOR SPACING NOTES**
- Spacing for specific radii may be interpolated from the table.
 - Values shown for S in the table are computed from the formula $S = 3\sqrt{R-50}$, where S = delineator spacing and R = horizontal curve radius. Values are rounded to the nearest 5 feet.

- NOTE:**
- Match the color of the reflective element with the edge line.
 - Use yellow reflective elements for triple delineators installed to mark obstructions.
 - Install double delineators on 100-foot spacing for acceleration and deceleration lanes or to mark changes in width.
 - Install reflective elements according to the manufacturer's recommendations.
 - Alternate delineator types may be used if approved. Provide delineators conforming to the MUTCD and install according to the manufacturer's recommendations.
 - Place delineators at a constant distance from the edge of the pavement. Where guardrail intrudes into the space between the edge of pavement and the delineator offset, locate the delineator immediately behind the guardrail.
 - A minimum of 12 holes spaced on 1-inch centers are required for all rigid posts. See Subsection 718.04.
 - Provide anti-theft hardware for mounting retroreflectors.
 - See Subsection 718.05 for rigid post requirements.

U.S. DEPARTMENT OF TRANSPORTATION, FHWA OFFICE OF FEDERAL LANDS HIGHWAY	CFLHD DETAIL C633-51
DELINEATORS	SPECIFICATION FP-24
	APPROVED FOR USE 06/2024

NO SCALE