

NOTE:

1. Install fasteners according to the manufacturer's recommendations.
2. Provide check slots according to the manufacturer's recommendations.
3. Roll ends may be spliced in a check slot.
4. Trapezoidal ditch shown. Similar details for a V ditch.

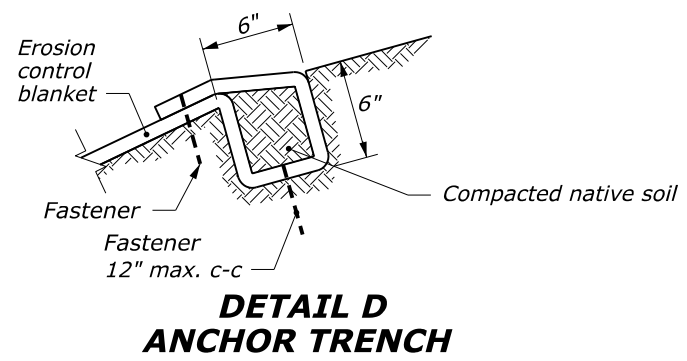
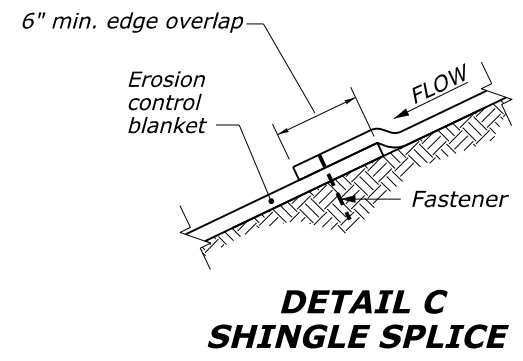
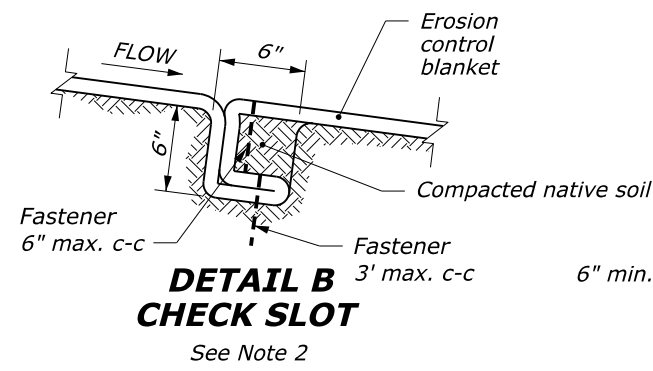
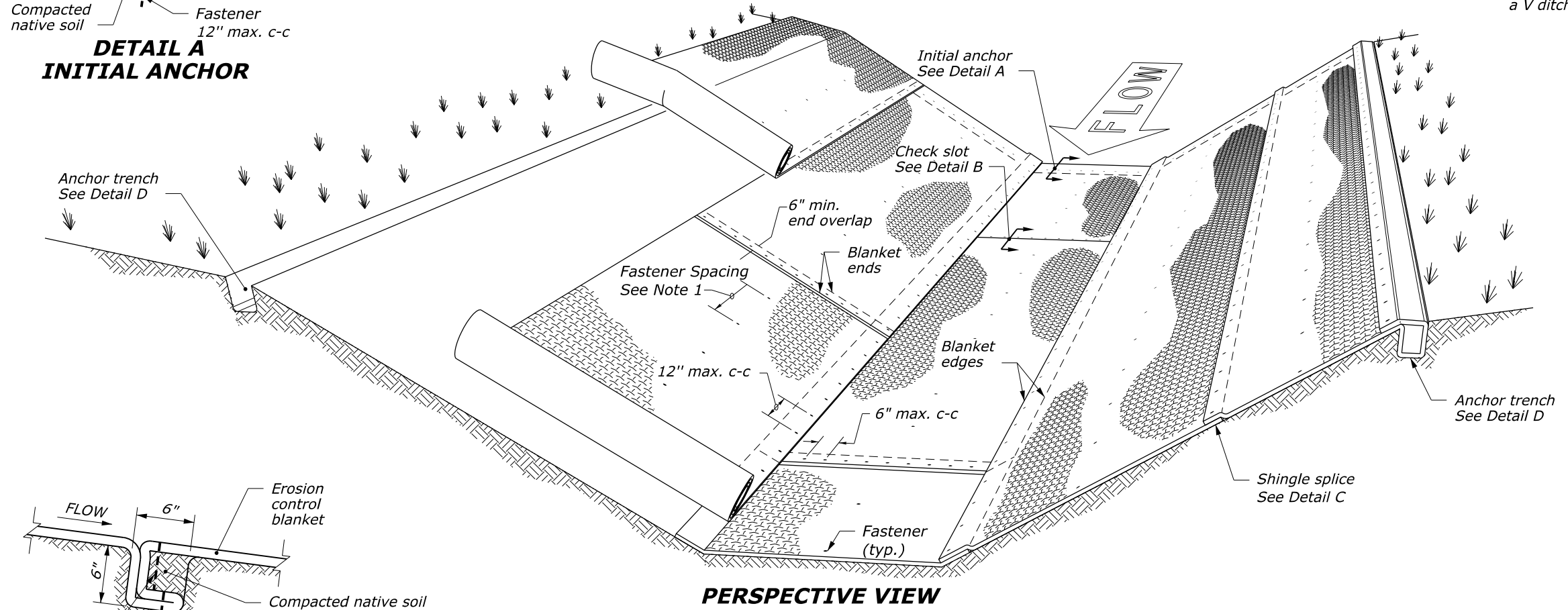
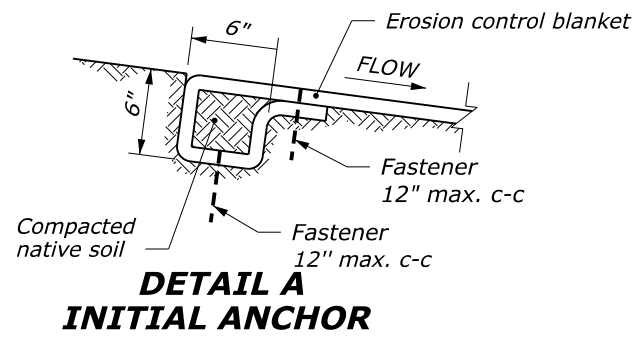

K:\CADD_Coordinator\ORD Drawings\Details\C629-51.dgn [Det C629-51] 1 April 2026 8:24 AM

NO SCALE

| | |
|--|-----------------------------|
| U.S. DEPARTMENT OF TRANSPORTATION, FHWA OFFICE OF FEDERAL LANDS HIGHWAY | CFL STANDARD C629-51 |
| ROLLED EROSION CONTROL PRODUCT IN CHANNELS | SPECIFICATION FP-24 |
| | APPROVED FOR USE 06/2024 |

Notes to the Designer

Updated March 2026

Rolled Erosion Control Product in Channel

General Information

- Printing should be done from the **[Sheet]** View model

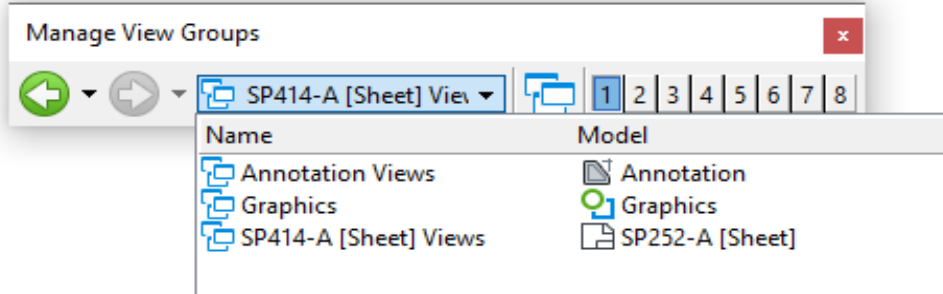

- **Appropriate Applications.** Erosion control blankets may be used for temporary or permanent soil stabilization in drainage channels. Blankets lessen the impact of soil erosion due to wind or water and provide a mulching layer for the establishment of vegetation. Erosion control blankets may be made of a variety of materials, such as jute, straw, or excelsior, providing variable longevity.
- **Limitations.** Erosion control blankets are typically used in ditches with velocities less than 9 ft/s. Erosion control blankets may be used under riprap check dams on steep slopes.
- **Layout Guidance.** Show locations of matting in the erosion and sediment control plans. Use the pattern EC_MAT in the cell library CFL_ErosionControl.cel.

Applicable SCRs

- **None for FP-24**
- **Section 629 (FP-14):** <https://flh.fhwa.dot.gov/resources/specs/fp-14/cfl/documents/S629-14.docx>

Typical Pay Item Used

- 62901-[0100 through 1400] Rolled erosion control product, type xx [SQYD] OR
- 62902-[0100 through 1400] Rolled erosion control product, type xx [ACRE]

Updates

- **January 2011**
 - New CFL Detail drawing
- **August 2014**
 - Updated for FP-14
 - Updated Border
- **October 2021**
 - Updated for OpenRoads Designer
- **February 2024**
 - Updated border; Updated for FP24
- **March 2026**
 - Updated border to CFL Standard