

**NOTE:**

1. Install fasteners according to the manufacturer's recommendations.
2. Overlap in the direction of the prevailing wind.

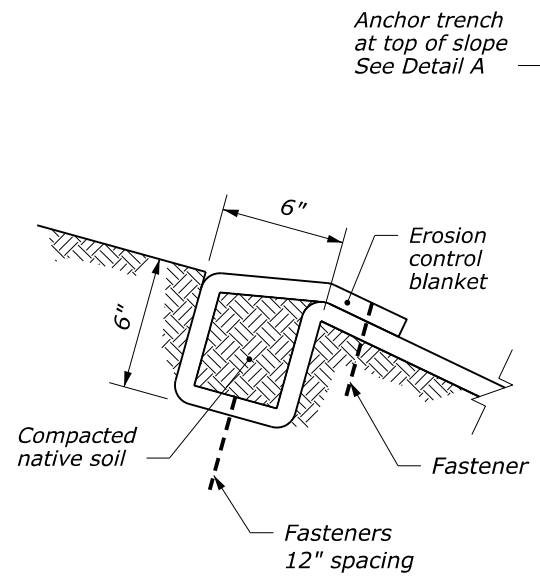

**DETAIL A  
ANCHOR TRENCH  
AT TOP OF SLOPE**

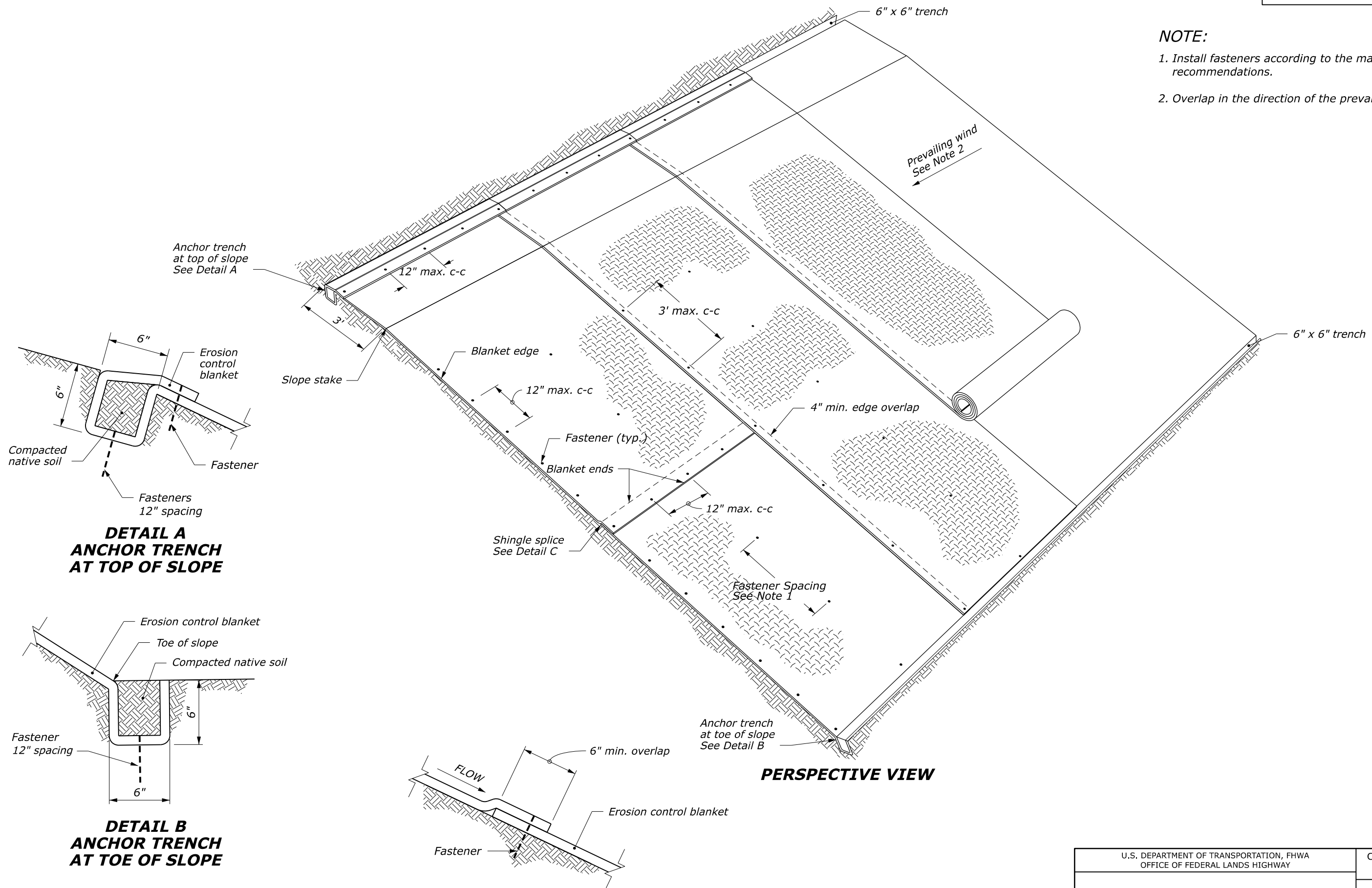
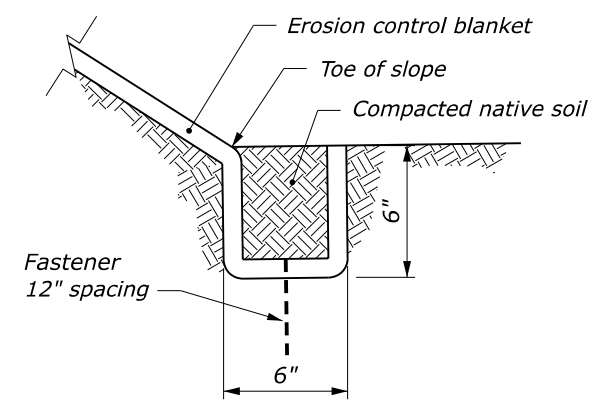

**DETAIL B  
ANCHOR TRENCH  
AT TOE OF SLOPE**

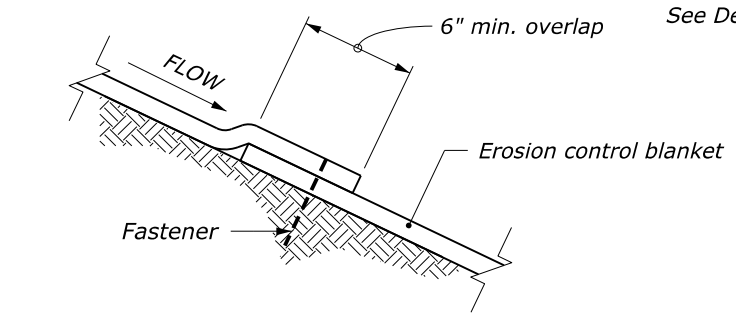

**DETAIL C  
SHINGLE SPLICE**

**PERSPECTIVE VIEW**

NO SCALE

K:\CADD\_Coordinator\ORD Drawings\Details\C629-50.dgn [Det C629-50]

U.S. DEPARTMENT OF TRANSPORTATION, FHWA OFFICE OF FEDERAL LANDS HIGHWAY	CFL STANDARD C629-50
<b>ROLLED EROSION CONTROL PRODUCT ON SLOPES</b>	SPECIFICATION FP-24
	APPROVED FOR USE 06/2024

## Notes to the Designer

Updated March 2026

### Rolled Erosion Control Product on Slopes

#### General Information

- Printing should be done from the **[Sheet]** View model

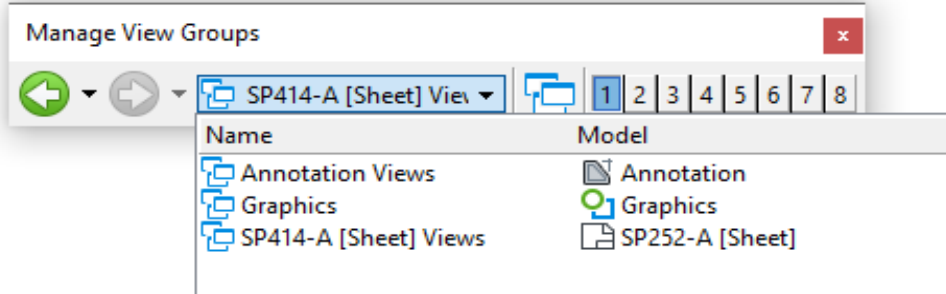

- **Appropriate Applications.** Erosion control blankets may be used for temporary or permanent soil stabilization on slopes. Blankets lessen the impact of soil erosion due to wind or water and provide a mulching layer for the establishment of vegetation. Erosion control blankets may be made of a variety of materials, such as jute, straw, or excelsior.
- **Limitations.** Erosion control blankets are typically used on slopes between 1V:1H and 1V:3H.
- **Layout Guidance.** Show locations of matting in the erosion and sediment control plans. Use the pattern EC\_MAT in the cell library CFL\_ErosionControl.cel.

#### Applicable SCRs

- **None for FP-24**
- **Section 629 (FP-14):** <https://flh.fhwa.dot.gov/resources/specs/fp-14/cfl/documents/S629-14.docx>

#### Typical Pay Item Used

- 62901-[0100 through 1400] Rolled erosion control product, type xx [SQYD] OR
- 62902-[0100 through 1400] Rolled erosion control product, type xx [ACRE]

#### Updates

- **January 2011**
  - New CFL Detail drawing
- **August 2014**
  - Updated for FP-14
  - Updated Border
- **October 2021**
  - Updated for OpenRoads Designer
- **February 2024**
  - Updated border; Updated for FP24
- **March 2026**
  - Updated border to CFL Standard